

MINI-MAX/51-C2

Single Board Computer

Technical Manual

Date: 22 July, 2010

Document Revision: 1.03



BiPOM Electronics

16301 Blue Ridge Road, Missouri City , Texas 77489
Telephone: 1-713-283-9970. Fax: Fax: 1-281-416-2806
E-mail: info@bipom.com
Web: www.bipom.com

© 1996-2010 by BiPOM Electronics. All rights reserved.

MINI-MAX/51-C2 Single Board Computer Technical Manual. No part of this work may be reproduced in any manner without written permission of BiPOM Electronics.

All trademarked names in this manual are the property of respective owners.

WARRANTY:

BiPOM Electronics warrants MINI-MAX/51-C2 for a period of 1 year. If the board becomes defective during this period, BiPOM will at its option, replace or repair the board. This warranty is voided if the product is subjected to physical abuse or operated outside stated electrical limits. BiPOM Electronics will not be responsible for damage to any external devices connected to MINI-MAX/51-C2. BiPOM Electronics disclaims all warranties express or implied warranties of merchantability and fitness for a particular purpose. In no event shall BiPOM Electronics be liable for any indirect, special, incidental or consequential damages in connection with or arising from the use of this product. BiPOM Electronics' liability is limited to the purchase price of this product.

1. Overview

MINI-MAX/51-C2 is a general purpose, low-cost and highly-expandable micro-controller system. It is based on the ATMEL AT89C51ED2 single-chip Flash micro-controller. This micro-controller features

- 64 Kilobytes of In-System Re-programmable Downloadable Flash Memory
- 256 bytes of RAM
- 1792 bytes of XRAM
- 9-sources 4-level Interrupts
- Programmable Counter Array with
 - High Speed Output
 - Compare/Capture
 - Pulse Width Modulator
- Three 16 bit Timer/Counters
- Programmable Enhanced UART Serial Channel
- SPI Serial Interface
- Programmable Watchdog Timer
- 32 general purpose I/O pins

MINI-MAX/51-C2 board complements these features by providing

- 512-byte Serial EEPROM (optional up to 128-Kilobyte EEPROM)
- RS232 Serial Port connector for In-circuit Programming and for data communications
- 5-channel 10-bit ADC with 4.096V internal or an external voltage reference source
- 10-pin connector for matrix and non-matrix keypads
- Dual-row 14-pin LCD connector (with software contrast adjustment for LCD)
- 20-pin Expansion connector for peripheral boards (<http://www.bipom.com/peripherals.php>)
- Microchip PIC16F818 secondary micro-controller to provide In-circuit Programming of the main Flash micro-controller through the RS232 Serial Port and to provide 5-channel 10-bit ADC using the 4.096V internal or an external voltage reference source
- On-board 5 Volt regulator
- 6 VDC power supply (Other 6 to 12VDC power sources can be used)
- Dimensions of 2.35 X 2.40 inches (5.97 X 6.10 centimeters).
- Mounting holes of 0.138 inches (3.5 millimeters) are on four corners.
- 0° - 70° C operating, -40° - +85° C storage temperature range.

The Flash micro-controller can be serially programmed while in the target application circuit. Customers can program the micro-controller with the most recent firmware or custom firmware. This function of the FLASH micro-controller simplifies new program development and debugging. Downloading of a program to the micro-controller typically takes few seconds.

8051/52, BASCOM51, SDCC development systems based on Micro-IDE (<http://www.bipom.com/microide.php>) Integrated Development Environment from BiPOM Electronics, fully support in-system programming and debugging on the MINI-MAX/51-C2 board using the serial port.

A Windows-based program WinLoad (<http://www.bipom.com/mm51c2soft.php>) is also provided to download programs to the board.

3. Functional Blocks

Figure 1 shows the block diagram of the MINI-MAX/51-C2 system

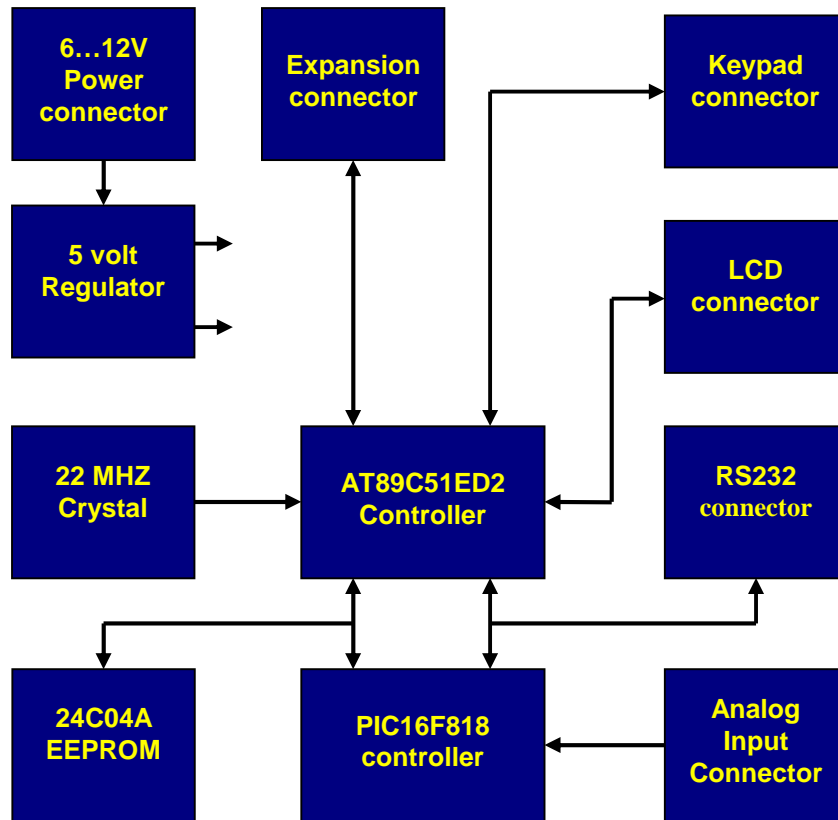

Figure 1

Micro-controller

MINI-MAX/51-C2 has an ATMEL AT89C51ED2 micro-controller (U2). Micro-controller ports and power lines are provided on a 20-pin expansion bus for interfacing to peripherals and other external circuits. AT89C51ED2 has 4 ports that are available on the 8051 family of micro-controllers: P0 ... P3.

P0 has open collector outputs that are available on the LCD connector with 4.7K pull-up (RB1). P1 and P2 are general-purpose bi-directional input/output ports. Port 2 is available on the keypad connector. P1 and P3 are available on the expansion connector. P3 pins can either be used as general-purpose input/output pins or have special purposes such as asynchronous serial port, interrupt inputs and timer inputs.

More information on the AT89C51ED2 micro-controller can be obtained from ATMEL web site at <http://www.atmel.com>.

Secondary Micro-controller

MINI-MAX/51-C2 has a Microchip PIC16F818 micro-controller to select an In-circuit Programming mode or Run mode of the main Flash micro-controller. When a Run mode is used, PIC16F818 works as an I2C slave peripheral device and can provide 5-channel 10-bit ADC using the 4.096V internal or an external voltage reference source.

In-System Programming

AT89C51ED2 micro-controller can be re-programmed remotely over the RS-232 interface using a second micro-controller on the board (PIC16F818). The in-circuit programming feature simplifies program development on the board since downloading programs from a host PC takes only few seconds. User programs can also be debugged over the serial port.

8051/52, BASCOM51, SDCC development systems based on Micro-IDE Integrated Development Environment from BiPOM Electronics, fully support In-System Programming and debugging on the MINI-MAX/51-C2 using the serial port.

The on-chip Downloadable Flash of AT89C51ED2 allows the program memory to be reprogrammed in-system through RS-232 serial interface.

The board operates in the two modes:

- 1- RUN mode
- 2- PROGRAM mode

Run mode is a standard mode when AT89C51ED2 is running its own program.

Program mode is a special mode when the hardware conditions during the reset pulse forces the on-chip boot loader execution.

PC changes the board mode through the RS-232 serial interface by a using of RTS line.

PIC16F818 is polling this line permanently and if the signal changes the level then PIC16F818 switches the board mode.

EEPROM

MINI-MAX/51-C2 uses a 24C04 (U3) 512 byte Electrically Erasable Programmable Read-Only-Memory (EEPROM). Typically this EEPROM is used for storing calibration values for sensors, customer identification, serial number and other parameters. This EEPROM is on a socket and can easily be replaced with higher capacity EEPROM's (up to 128 Kilobytes).

Keypad connector

8 pins of AT89C51ED2 are connected to the Keypad Connector. Matrix keypads such 3 by 5 or 4 by 4 can be connected directly to the connector. 5 Volt and Ground power lines are also available on the connector.

The keypad connector can also be used as a general purpose 8-pin input/output port.

Table 1 shows the pin assignments for the Keypad connector.

Keypad Connector (J1)

Name	Signal	Pin
VCC	+5V	10
GND	Ground	9
P2.7	In/Out	8
P2.6	In/Out	7
P2.5	In/Out	6
P2.4	In/Out	5
P2.3	In/Out	4
P2.2	In/Out	3
P2.1	In/Out	2
P2.0	In/Out	1

Table 1

Asynchronous Serial Port

One asynchronous RS232 serial port is available on a 9-pin male D connector J2. RS232 port can be used by both a PC for In-circuit Programming of the T89C51ED2 through PIC16F818 microcontroller and by T89C51ED2 for data communications.

RTS line is used by an external host such as a PC to put MINI-MAX/51-C2 in program or run mode. Therefore, user applications must not use RTS.

Many users try to use HyperTerminal to send some data bytes to a Mini-Max/51-C2 board. HyperTerminal forces a board to PROGRAM MODE by RTS line. AT89C51ED2 program can not be executed if HyperTerminal occupies RS-232 port. We advise to use Micro-IDE terminal window instead of HyperTerminal.

Table 2 shows the pin assignments for RS232 serial port connector

Serial Port Connector (J2)

Name	Signal	Pin
-	Not Connected (NC)	1
TXD	MM51C2 Input	2
RXD	MM51C2 Output	3
DTR	NC or Vcc from MM51C2	4
GND	GND	5
-	NC	6
CTS	CTS (MM51C2 Output)	7
RTS	RTS (MM51C2 Input)	8
-	NC	9

Table 2

LCD Connector

Alphanumeric 24 Characters x 2 lines LCD such as BiPOM's LCD242 (http://www.bipom.com/lcd_parallel.php) or any generic LCD display with 4-bit parallel interface can be connected directly to MINI-MAX/51-C2.

LCD Connector (J3)

Signal	Pin	Pin	Signal
P0.7	14	13	P0.6
P0.5	12	11	P0.4
not connected	10	9	not connected
not connected	8	7	P0.3
P0.2	6	5	P0.1
P0.0	4	3	Vee
VCC (+5V)	2	1	GND

Table 3

Input/Output expansion bus

The 16 control pins and 5 Volt power supply pins are available on the 20-pin connector (J4) for interfacing to existing peripheral boards. A peripheral board can be connected to MINI-MAX/51-C2 either as a piggyback daughter-board using standoffs or can be placed away from the MINI-MAX/51-C2 board using a 20-wire ribbon cable (Part #: EXPCABLE-6). Table 4 shows the pin assignments for the connector.

Input/Output Connector (J4)

Signal	Pin	Pin	Signal
P3.0	20	19	P3.1
P3.2	18	17	P3.3
P3.4	16	15	P3.5
P3.6	14	13	P3.7
P1.0	12	11	P1.1
P1.2	10	9	P1.3
P1.4	8	7	P1.5
P1.6	6	5	P1.7
VCC (+5V)	4	3	GND
VCC (+5V)	2	1	GND

Table 4

Analog Port Terminal

5-channel 10-bit ADC of Microchip PIC16F818 micro-controller is available on the 10-pin terminal J6. The ADC can operate with a 4.096V internal or an external voltage reference source

Table 5 shows the pin assignments for the terminal

Analog Port Terminal (J6)

Name	Signal	Pin
AN0	MM51C2 Analog Input	1
AN1	MM51C2 Analog Input	2
GND	GND	3
AN2	Analog Input or External Vref(-) Input	4
GND	GND	5
AN3	Analog Input or External Vref(+) Input	6
VREF	Vref = 4.096V from MM51C2	7
AN4	MM51C2 Analog Input	8
GND	GND	9
VCC	Vcc from MM51C2	10

Table 5

Power Supply Unit

MINI-MAX/51-C2 board comes with a 6 Volts unregulated DC power supply. Other power supplies can also be used. External power supply should be able to supply 6 to 12 Volts DC at minimum 200mA current (more if peripheral boards will be used). The inner pin of the supply connector is positive and the outer ring is negative.

WARNING: Correct polarity should be observed when applying external DC supply to Power connector.

MINI-MAX/51-C2 has an on-board 5 Volt regulator LM7805 (U5).

CAUTION: Depending on the current requirements of the any external circuitry such as peripheral boards that are attached to MINI-MAX/51-C2 and the level of input voltage applied, the power regulator U1 may dissipate enough heat to cause skin injury upon touch. Contact with this regulator should be avoided at all times, even after the power to circuit has been switched off.

4. Peripherals

MINI-MAX/51-C2 can be connected to a wide variety of low-cost peripheral boards to enhance its functionality. Some possibilities are:

- Prototyping board (PROTO-1)
- Training Board (TB-1)
- Digital Input/Output Expander Board (DIO-1)
- Analog (ADC and DAC) Input/Output Boards (DAQ-2543, DAQ-2543-DA1)
- Relay peripheral boards (RELAY-1, RELAY-2, RELAY-4REED)
- Real Time Clock boards with a Multi Media Card socket (RTC board, MMC/RTC board)
- A peripheral board with four 7-segment LED displays with decimal point (LED-1).

Peripheral boards can either be stacked on top of MINI-MAX/51-C2 using stand-offs or connected in a chain configuration using flat ribbon cable. Figure 2 shows how MINI-MAX/51-C2 can be connected to a peripheral board in a stacked fashion. Figure 3 shows chain connection.

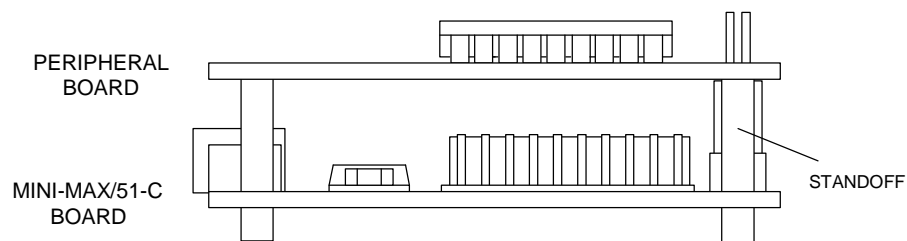

Figure 2

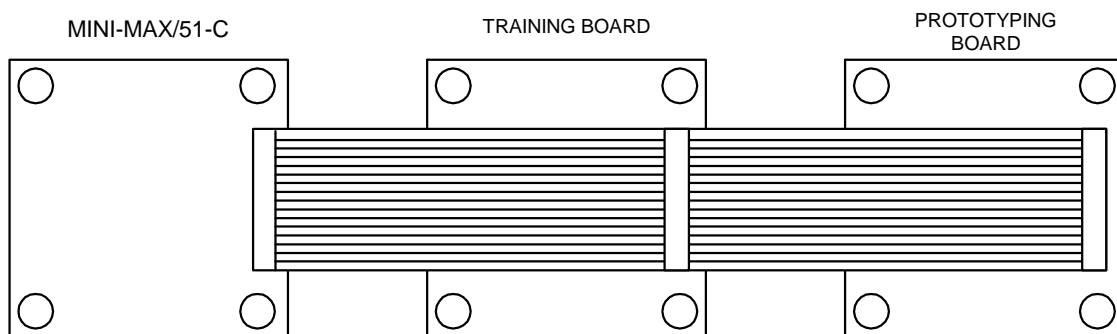

Figure 3

More details on BiPOM Peripheral boards are available from http://www.bipom.com/periph_boards.php

5. Software

8051/52, BASCOM51, and SDCC development systems provide many examples that demonstrate accessing on-board peripherals and performing self-diagnostics.

Please download any suitable development system from

<http://www.bipom.com/8051dev.php>

<http://www.bipom.com/bascom51.php>

<http://www.bipom.com/sdcc.php>

Any of the development systems provides MINI-MAX/51-C Loader.

Also, stand-alone loaders are available to download program codes to the Mini-Max/51-C2:

Windows MINI-MAX/51-C Command-line Loader

DOS MINI-MAX/51-C Command-line Loader

WinLoad Windows Loader

Please visit <http://www.bipom.com/mm51c2soft.php>

6. Board Layout

Layout of MINI-MAX/51-C2 board is shown below:

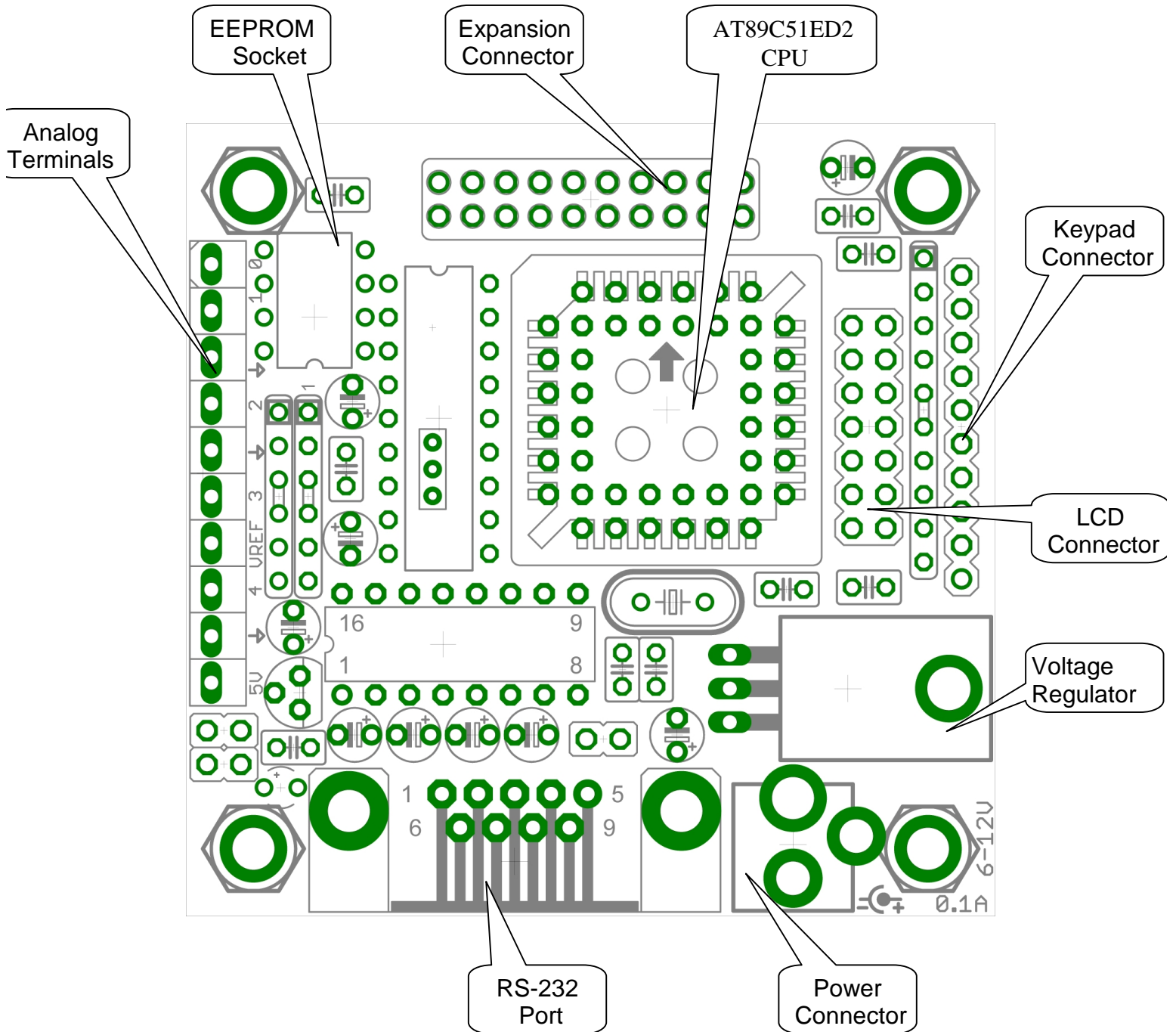

7. Schematics

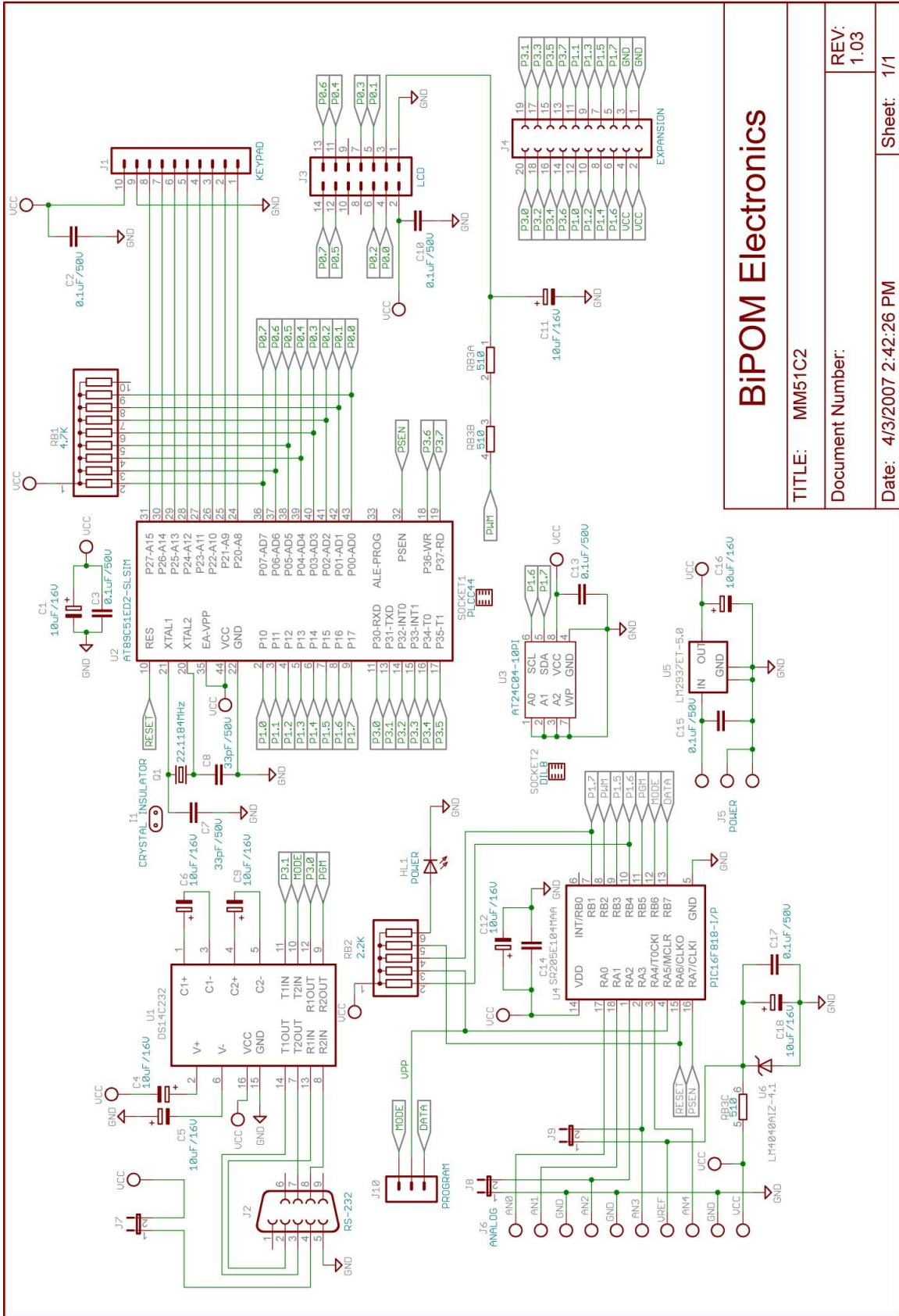

BiPOM Electronics	
TITLE:	MM51C2
Document Number:	
Date:	4/3/2007 2:42:26 PM
REV:	1.03
Sheet:	1/1