

MINI-MAX/P18

Single Board Computer

Technical Manual

Document Revision: 1.06

Date: 04 October 2008



BiPOM Electronics, Inc.

16301 Blue Ridge Road, Missouri City , Texas 77489
Telephone: 1-713-283-9970. Fax: 1-281-416-2806
E-mail: info@bipom.com
Web: www.bipom.com

TABLE OF CONTENTS

1. OVERVIEW	3
2. SPECIFICATIONS	3
3. FUNCTIONAL BLOCKS	4
4. PERIPHERALS	8
5. SOFTWARE	12
6. BOARD LAYOUT	12
7. SCHEMATICS	13

WARRANTY:

BiPOM Electronics warrants MINI-MAX/P18 for a period of 1 year. If the board becomes defective during this period, BiPOM Electronics will at its option, replace or repair the board. This warranty is voided if the product is subjected to physical abuse or operated outside stated electrical limits. BiPOM Electronics will not be responsible for damage to any external devices connected to MINI-MAX/P18. BiPOM Electronics disclaims all warranties express or implied warranties of merchantability and fitness for a particular purpose. In no event shall BiPOM Electronics be liable for any indirect, special, incidental or consequential damages in connection with or arising from the use of this product. BiPOM's liability is limited to the purchase price of this product.

© 2004-2008 by BiPOM Electronics. All rights reserved.

MINI-MAX/P18 Single Board Computer Technical Manual. No part of this work may be reproduced in any manner without written permission of BiPOM Electronics.

All trademarked names in this manual are the property of respective owners.

1. Overview

MINI-MAX/P18 is a general purpose, low-cost, highly reliable, and highly expandable micro-controller system. It is based on the Microchip Technology PIC18F458 single-chip Flash micro-controller. This microcontroller features

- 32K In-System Re-programmable Downloadable Flash Memory
- 1.5K RAM
- 256 bytes of EEPROM data memory
- 15 Interrupt Sources
- Two 8-bit Timers / counters with prescalers
- One 16-bit timer / counter
- Two 16-bit compare / capture PWM modules
- 10-bit 8-channel ADC
- Two analog comparators
- Programmable UART Serial Channel
- SPI and Master I2C Serial Interfaces
- Controller Area Network (CAN) Bus
- Programmable Watchdog Timer
- Brown-out detector
- 33 general purpose I/O pins

MINI-MAX/P18 board complements these features by providing

- 512-byte EEPROM (optional 128-Kilobyte EEPROM)
- RS232 Serial Port
- In-circuit Programming of the micro-controller through the serial port
- Precision reference voltage source for ADC
- Keypad connector
- LCD connector (with programmable contrast adjustment for LCD)
- Expansion bus interface to low-cost peripheral boards.

MINI-MAX/P18 board also supports PIC16F877A, PIC18F442 and PIC18F452 micro. These devices are pin compatible with the PIC18F458 and can be directly placed into the MINI-MAX/P18 PLCC-44 socket.

MINI-MAX/P18 is a highly reliable system:

- 2-layer Printed Circuit Board, no vias.
- Hardware Watchdog timer of PIC18F458 provides protection against software failures and lock-ups.
- PIC16F648 In-System programmer supports Software Watch-Dog timer. Timeout is selectable from 1 to 127 seconds. If this function is activated, the PIC18F458 should communicate with PIC16F648 through I2C bus to prevent RESTART. When PIC18F458 fails to communicate with PIC16F648, the PIC16F648 will generate a RESET signal for PIC18F458.
- PIC16F648 generates reliable RESET signal in power-up and in brownout.

2. Specifications

Dimensions are 2.35 X 2.40 inches (5.97 X 6.10 centimeters). Mounting holes of 0.125 inches (3 millimeters) on four corners. 0° - 70° C operating, -40° - +85° C storage temperature range.

3. Functional Blocks

Figure 1 shows block diagram of the MINI-MAX/P18 system

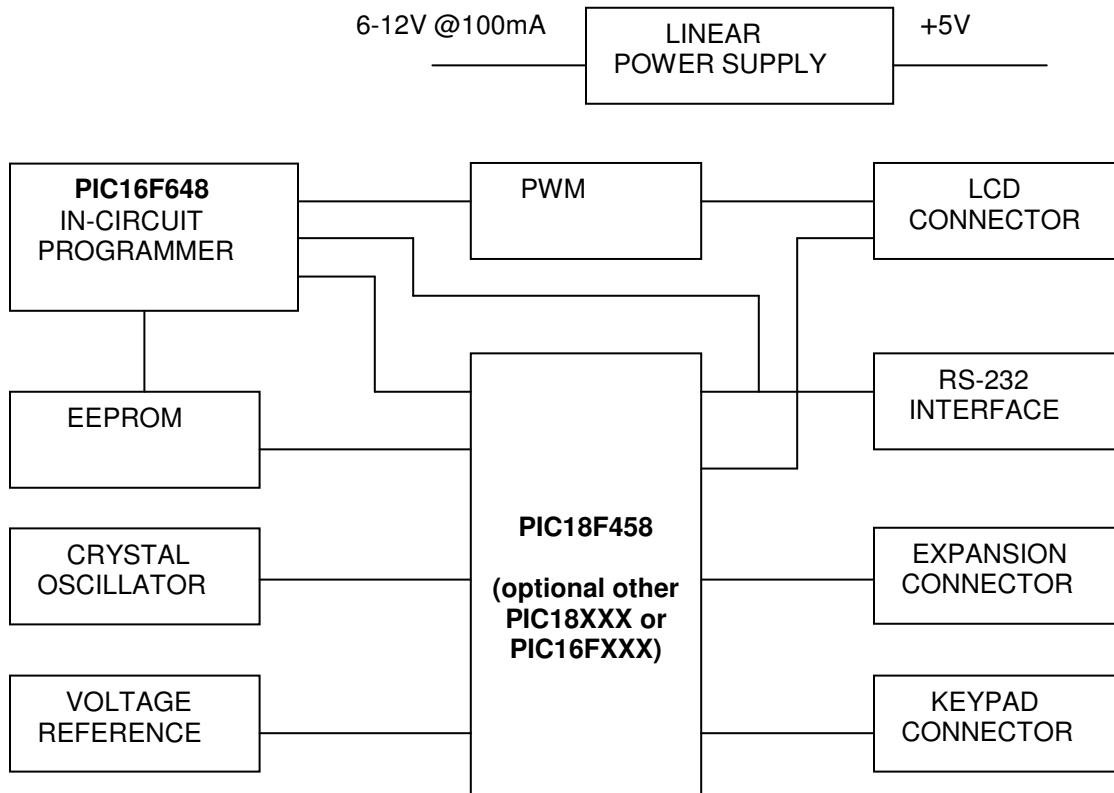

Figure 1

Micro-controller

MINI-MAX/P18 has a Microchip PIC18F458 micro-controller (U2). Micro-controller ports and power lines are provided on a 20-pin Expansion bus (J4) for interfacing to peripherals and other external circuits. PIC18F458 has five ports: 6-bit PORTA, 8-bit PORTB, 8-bit PORTC, 8-bit PORTD and 3-bit PORTE. All of these port pins can be used as general I/O.

Four PORTB lines and three PORTE lines are available on the LCD connector. PORTE lines can be used as analog inputs. Some of PORTA, PORTB and PORTC lines are available on the Expansion connector for general I/O or have special alignments such as asynchronous serial port, interrupt inputs, A/D inputs, and timer inputs. PORTD is available on the keypad connector.

MINI-MAX/P18 has Pulse Width Modulation (PWM) circuit, which can vary LCD contrast. Alternatively it can be used as a low speed analog output.

More information on the PIC18F458 micro-controller can be obtained from Microchip's web site at www.microchip.com.

Using the Analog to Digital converter

PIC18F458 has an 8-channel 10-bit analog to digital converter. It can use on-board +5V power (Vcc) as reference voltage. For best accuracy and noise performance, ADC can be configured to use external reference that is provided on the MINI-MAX/P18 board. It is permanently connected to RA3. Also, for this purpose MINI-MAX/P18 board has separate ground circuit for analog signals. This circuit is RA2 (pin #7 on expansion connector). JP3 jumper should be set to use RA2 as the analog ground. MINI-MAX/P18 board comes with JP3 jumper, already installed at the factory.

EEPROM

MINI-MAX/P18 uses a 24C04 (U5) 512-byte Electrically Erasable Programmable Read-Only-Memory (EEPROM). Typically this EEPROM is used for storing calibration values for sensors, customer identification, serial number and other parameters. This EEPROM is on a socket and can easily be replaced with higher capacity EEPROM's (up to 128 KiloBytes).

In-System Programming

PIC18F458 micro-controller can be re-programmed remotely over the RS-232 interface using a second micro-controller on the board (PIC16F648). The in-circuit programming feature simplifies program development on the board since downloading programs from a host PC takes only few seconds.

[MC Development System](#) based on [Micro-IDE](#) Integrated Development Environment from BiPOM Electronics fully supports in-system programming on the MINI-MAX/P18 board using the serial port. A Windows-based program [WinLoad](#) from BiPOM Electronics is provided to download programs to the MINI-MAX/P18 board.

Also, BiPOM Electronics provides a special piggyback module called [PIGGY](#). Using this module, the user can connect the Microchip MPLAB-ICD to MINI-MAX/P18.

Microchip's In-Circuit Debugger, MPLAB-ICD, is a powerful, low-cost development and evaluation kit for the FLASH PIC16F87XA microcontroller (MCU) family. MPLAB ICD utilizes the In-Circuit Debugging capability of the PIC16F87XA. This feature, along with Microchip's In-Circuit Serial Programming™ (ICSP™) protocol, offers cost-effective in-circuit FLASH programming and debugging from the graphical user interface of the MPLAB Integrated Development Environment (IDE). A designer can develop and debug source code by watching variables, setting break points, and single-stepping. Contact Microchip Technology's Web site at www.microchip.com for information on how to use the MPLAB ICD.

Keypad connector

8 pins of PORTD are connected to the Keypad connector. Many different keypads (for example, 3 by 5 or 4 by 4) can be connected directly to the keypad connector. 5 Volt and Ground power lines are also available on the Keypad connector. This connector can also be used as a general-purpose port.

Keypad Connector (J1)

Signal	Pin
RD0	1
RD1	2
RD2	3
RD3	4
RD4	5
RD5	6
RD6	7
RD7	8
Ground	9
Vcc	10

Table 1.

LCD Connector

This connector is intended for various types of alphanumeric LCD modules. RB0, RB1, RB2, RB4 are the 4-bit data bus, RE0, RE1, RE2 are the control signals. All these lines can be used as general purpose I/O. RE0-RE2 can serve as analog inputs. Vee is a slow analog PWM output to adjust contrast of LCD display. Alternatively, it can be used as a general-purpose analog output.

LCD Connector (J3)

Signal	Pin	Pin	Signal
Ground	1	2	Vcc
Vee	3	4	RE2
RE0	5	6	RE1
N/C	7	8	N/C
N/C	9	10	N/C
RB0	11	12	RB1
RB2	13	14	RB4

Table 2.

Power Supply Unit

MINI-MAX/P18 series boards come with a 6 Volt unregulated DC power supply. Other power supplies can also be used although this invalidates the warranty. External power supply should be able to supply 6 to 12 Volts DC at minimum 100mA current. The inner pin of the power supply connector is positive and the outer ring is negative.

WARNING: Correct polarity should be observed when applying external DC supply to Power terminal; otherwise MINI-MAX/P18 will be permanently damaged.

MINI-MAX/P18 has an on-board 5 Volt regulator (U3).

CAUTION: Depending on the current requirements of the any external circuitry such as peripheral boards that are attached to MINI-MAX/P18 and the level of input voltage applied, the power regulator U3 may dissipate enough heat to cause skin injury upon touch. Contact with this regulator should be avoided at all times, even after the power to circuit has been switched off.

Asynchronous Serial Port

One asynchronous RS232 serial port (J2) is available on MINI-MAX/P18.

U1 converts micro-controller's RXD and TXD pins to/from RS232 levels. U1 has built-in voltage-doubler and inverter that generates +/- 10 Volts for RS232 logic levels. RS232 port is made available on a 9-pin male D connector J2. Hand-held terminals, computers, modems and other serial devices may be connected to the RS232 port. CTS/RTS Modem control lines are provided on the RS232 port. CTS is used by external host such as a PC to put MINI-MAX/P18 in program or run modes. Therefore, user applications must not use CTS line.

RS232 Serial Port (J2)

Signal	Pin
Not Connected	1
Receive (RXD)	2
Transmit (TXD)	3
Not Connected	4
Ground	5
Not Connected	6
RTS	7
CTS	8
Not Connected	9

Table 3

Many users try to use HyperTerminal to send some data bytes to a MINI-MAX/P18 board. HyperTerminal forces a board to PROGRAM MODE by RTS line. PIC programs can not be executed if HyperTerminal occupies the RS-232 port. We advise to use Micro-IDE terminal window instead of HyperTerminal.

Expansion

Most of the micro-controller pins and the 5-Volt power supply lines are available on the 20-pin MINI-MAX/P18 Expansion connector (J4) for interfacing to external circuitry, prototyping boards and peripheral boards. MINI-MAX/P18 peripheral boards can be connected either as a piggyback daughter-board on MINI-MAX/P18 using standoffs or can be placed up away from MINI-MAX/P18 using a 20-wire ribbon cable. Peripherals section lists the available expansion boards. Table 4 shows the pin assignments for the MINI-MAX/P18 Expansion connector.

MINI-MAX/P18 Expansion (J4)

Signal	Pin	Pin	Signal
RC7	20	19	RC6
RB6	18	17	RB3
RC1	16	15	RA4
RC0	14	13	RA5
RB7	12	11	RC2
RA0	10	9	RA1
RC5	8	7	RA2
RC3	6	5	RC4
VCC	4	3	GND
VCC	2	1	GND

Table 4

4. Peripherals

MINI-MAX/P18 can be connected to a wide variety of low-cost peripheral boards to enhance its functionality. Some possibilities are:

- Prototyping board (PROTO-1)
- Training Board (TB-1)
- 4-digit 7-segment LED display board
- 12-bit Analog-To-Digital Converter Board
- Digital Input/Output Expander Board
- Real time clock + 128 MB flash card board
- Terminal board
- Reed relay board with 4 relays
- Power relay board with 2 relay
- Stepper motor driver board

Peripheral boards can either be stacked on top of MINI-MAX/P18 using stand-offs or connected in a chain configuration using flat ribbon cable. Figure 2 shows how MINI-MAX/P18 can be connected to a peripheral board in a stacked fashion. Figure 3 shows chain connection.

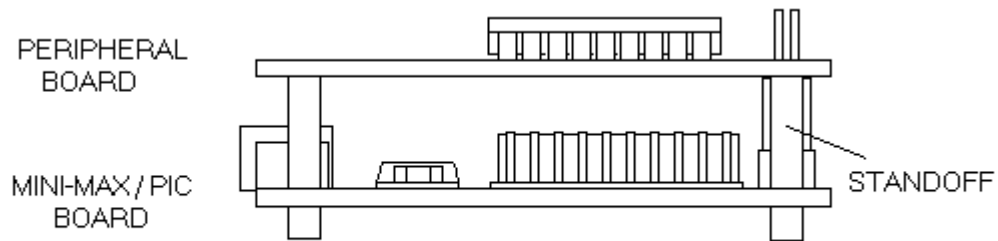

Figure 2

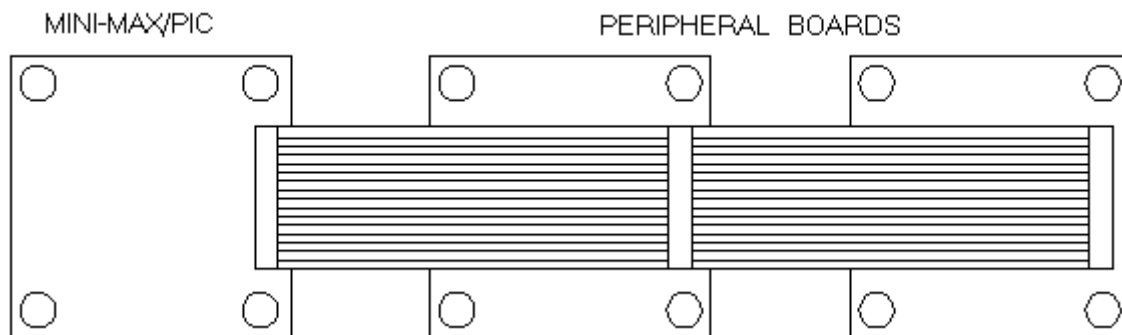

Figure 3

More details concerning BiPOM Peripheral boards are available from the link below:

www.bipom.com/peripherals.php

RS232 Devices

Various keypads and terminals may be connected to the RS232 port of MINI-MAX/P18 through connector J2. MINI-MAX/P18 can be connected to a host PC through the RS232 port. For example, MINI-MAX/P18 can be used as a remote data acquisition or control unit serving a host PC in a client-server configuration.

Connection to a host PC is accomplished by using a NULL-Modem cable. MINI-MAX/P18 end of this cable should be a 9-pin Female D connector for connection to J2 on the MINI-MAX/P18 board. Host PC end of this cable can be either 9-pin Female or 25-pin Female D Connector depending on available serial (COM) ports on the host PC.

MINI-MAX/P18 board comes with a NULL modem (LapLink) cable that has the following wiring connections:

MINI-MAX/P18 9-pin Female			Host PC 9-pin Female
RECEIVE DATA (RXD)	2	3	TRANSMIT DATA (TXD)
TRANSMIT DATA (TXD)	3	2	RECEIVE DATA (RXD)
GROUND	5	5	GROUND
RTS	7	8	CTS
CTS	8	7	RTS

MINI-MAX/P18 9-pin Female			Host PC 25-pin Female
RECEIVE DATA (RXD)	2	2	TRANSMIT DATA (TXD)
TRANSMIT DATA (TXD)	3	3	RECEIVE DATA (RXD)
GROUND	5	7	GROUND
RTS	7	5	CTS
CTS	8	4	RTS

Table 5

5. Software

MPASM development system provides a lot of examples for the MINI-MAX/P18 board to access on-board peripherals and perform self-diagnostics.

Please download the development system from www.bipom.com/mmpicsoft.php

Also, WinLoad Windows Loader is available to download program codes to the MINI-MAX/P18:

6. Board Layout

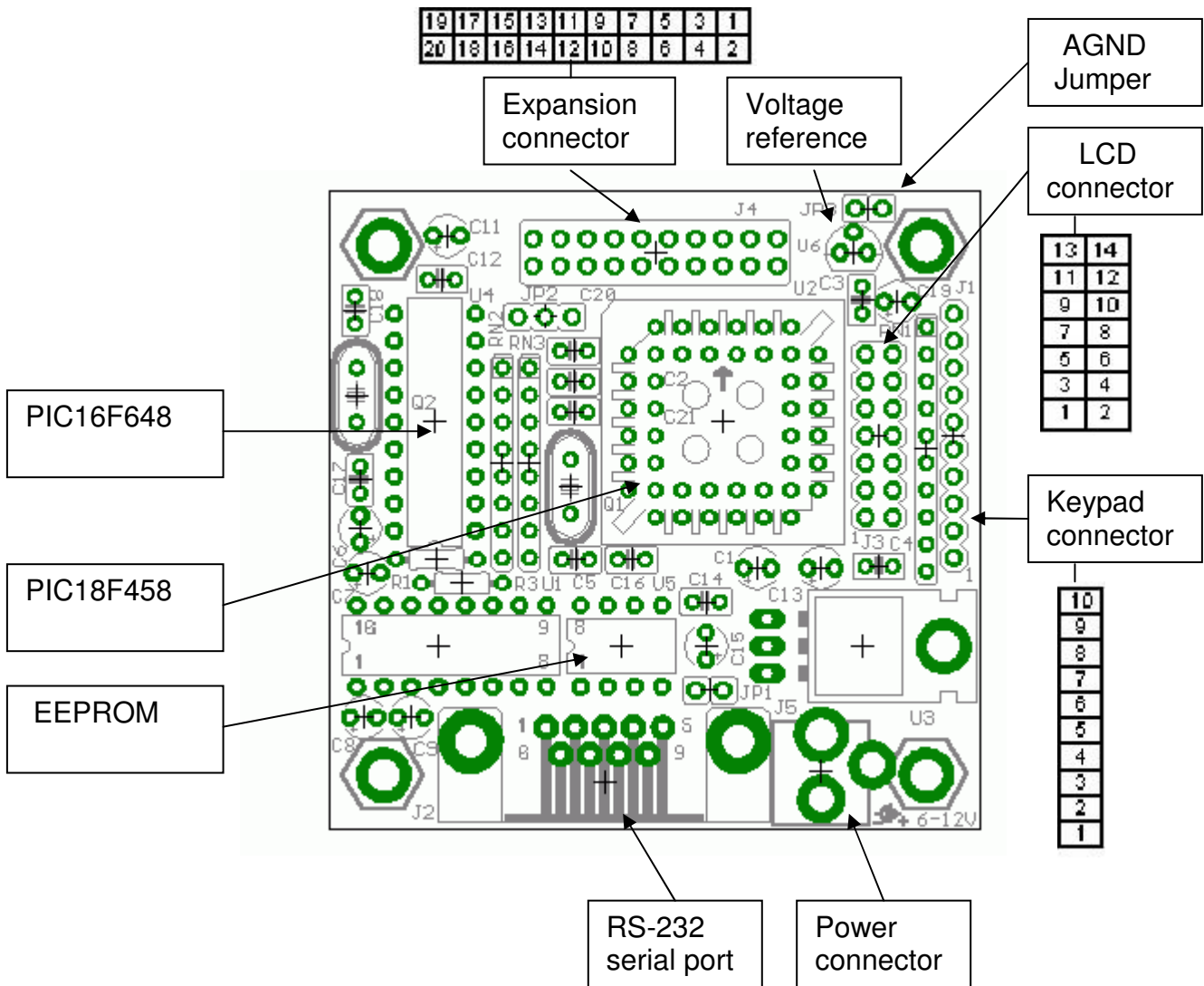

7. Schematics

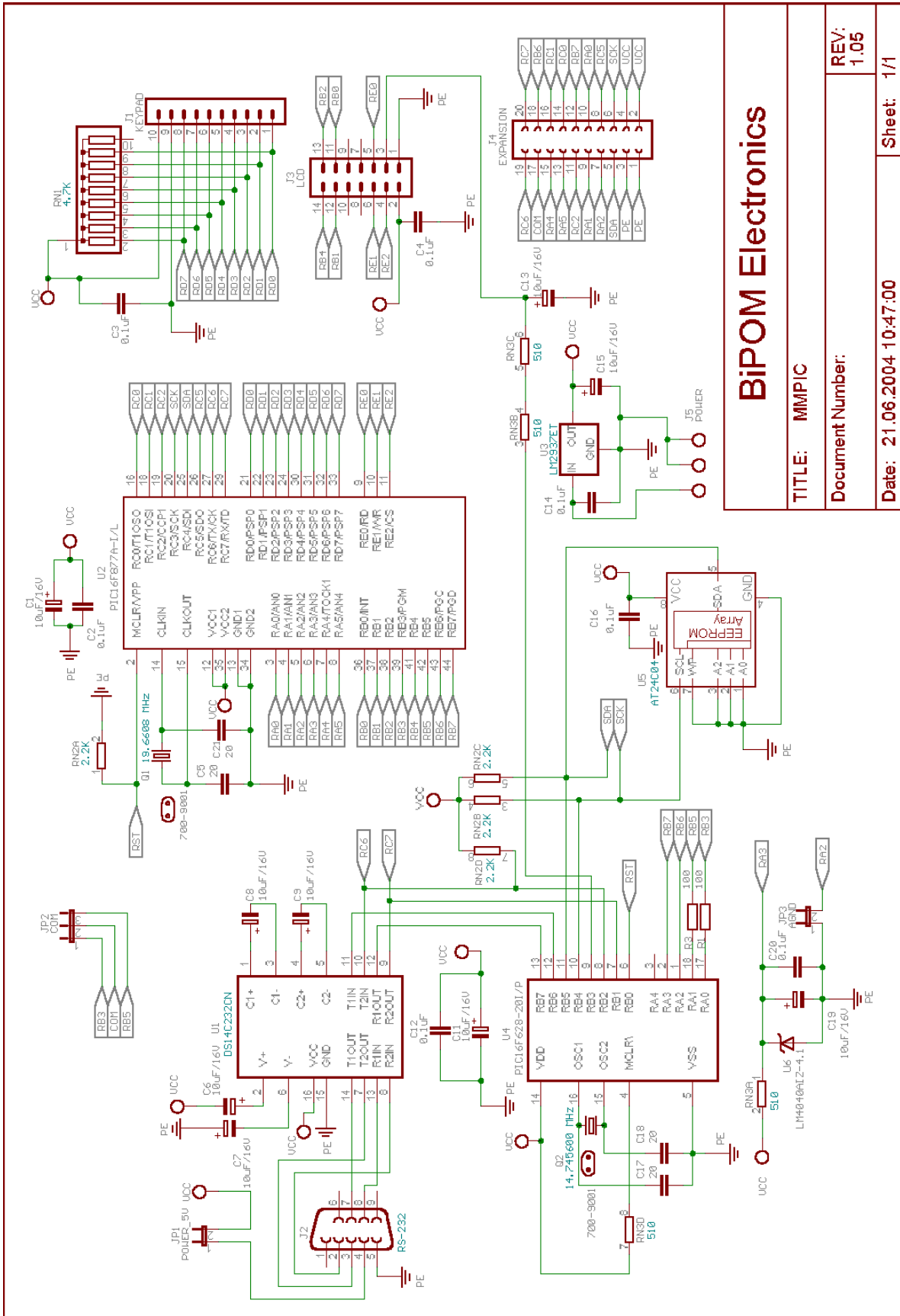

BiPOM Electronics

TITLE: MMPIC

Document Number:

Date: 21.06.2004 10:47:00

REV: 1.05

Sheet: 1/1