

# ACCESSORIES

## STRAIN RELIEF BOOTS FOR COAXIAL CONNECTORS

**Construction:** Molded of PVC.

**Color:** Available in 10 standard colors.

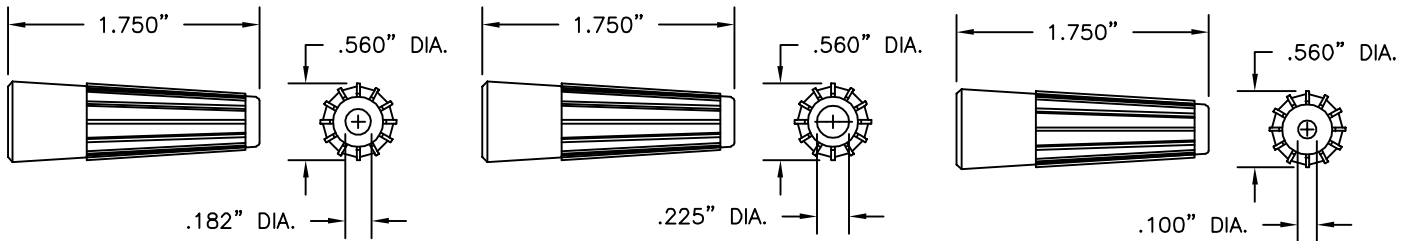

Part No.	Description
SR 58	For RG58C/U Cable

Part No.	Description
SR 59	For RG59/U Cable

Part No.	Description
SR 174	For RG174U Cable

## PART NO. Y3000

### IN-LINE Y BLOCK FOR MINIATURE CABLE

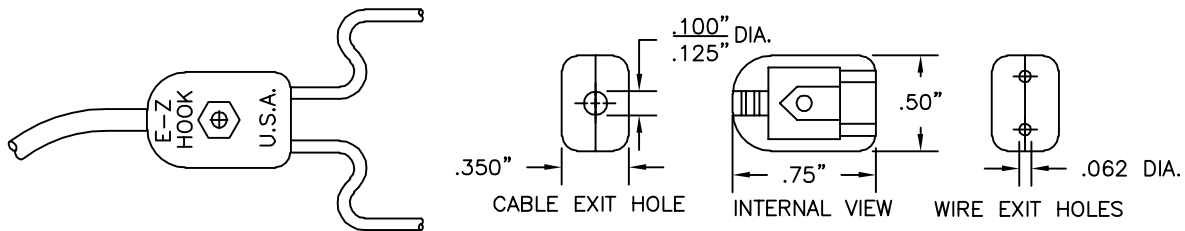

Part No.	Description
Y3000	Y Block for Miniature Cable

Insulated housing for Y splicing on RG 174/U cable. Cable entrance hole has built-in strain relief. Two .070" (1.78mm) diameter lead exit holes accommodate 22 or 20 AWG insulated lead wire.

**Construction:** Two-piece body molded of durable nylon. Completely field serviceable.

**Color:** Black.

## PART NO. Y 1000 AND Y1000-2

### IN-LINE Y BLOCK FOR STANDARD SIZE CABLES

Part No.	Description
Y1000	Y Block for Standard Cable
Y1000-2	Y Block for Large Cable

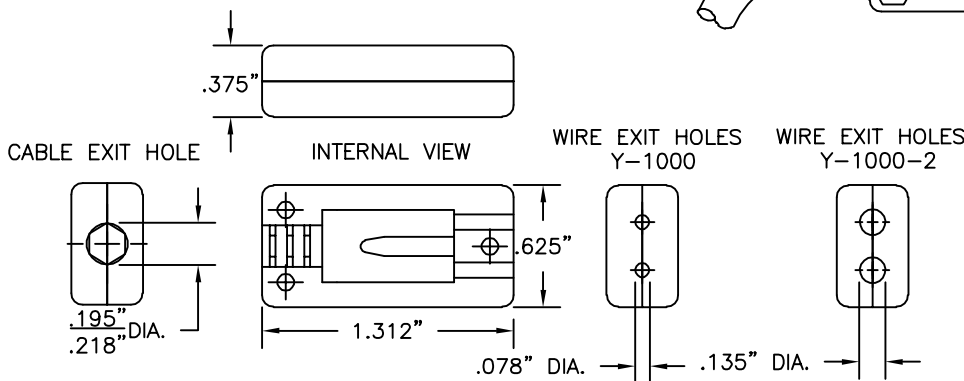
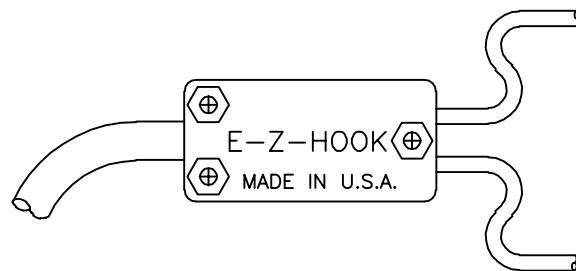

**Model Y1000** Insulated housing for Y splicing, has built-in strain relief. RG58C/U cable may be adapted to various size cables. Two .070" (1.78mm) diameter lead exit holes accommodate 22 or 20 AWG insulated lead wire.

**Model Y1000-2** has two .144" (3.58mm) diameter lead exit holes to accommodate most 14-18 AWG insulated lead wire.

**Construction:** Two-piece body molded of durable nylon. Completely field serviceable.

**Color:** Black

# ACCESSORIES

PART NO. Y1000-5

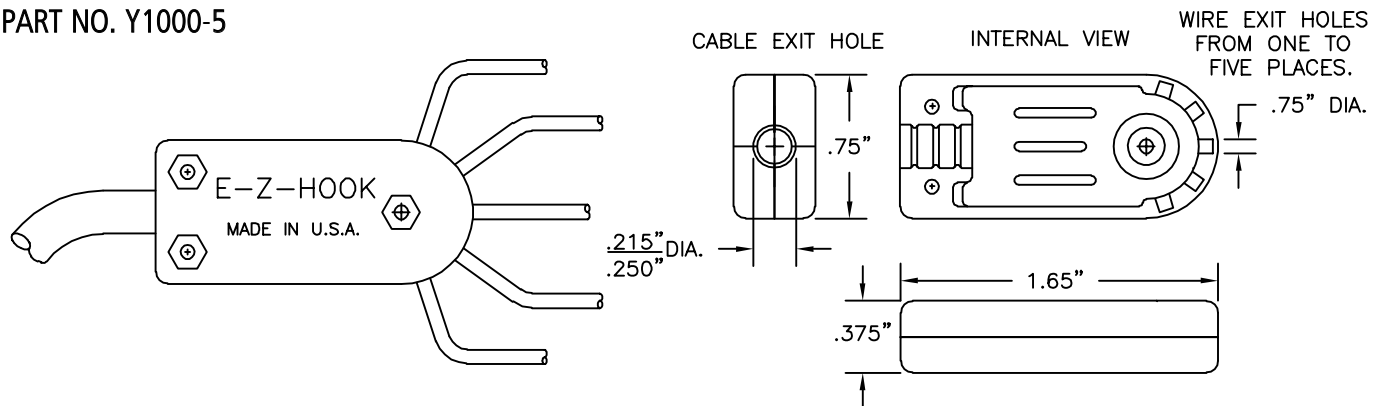

Model Y1000-5 insulated housing for Y splicing, has built-in strain relief. .215"/.250" diameter cable may be adapted to various size cables. One to five outlets .070"/.080" diameter lead exit holes accommodate 22 or 20 AWG insulated lead wire.

**Construction:** Two-piece body molded of durable nylon. Completely field serviceable.

**Color:** Black.

## TEST CABLE WALL BRACKETS

Sturdy wall-mount brackets with deep slots hold test leads and cables for easy selection.

Part No.	Description
<b>WB6</b>	6-Slot Wall Bracket

Small six-slot wall bracket for holding test leads and cables.

**Color:** Blue

**WB6 Dimensions:**

3.00" High x 5.00" Wide  
Fingers protrude 3.43"  
Slots are .25" wide  
Mounting holes are on 3.75" centers

Part No.	Description
<b>WB14</b>	13-Slot Wall Bracket

Large 13-slot wall bracket for holding test leads and cables.

Three distinct slot widths for various gauge cables.

**Color:** Blue

**WB14 Dimensions:**

3.00" High x 11.875" Wide  
Fingers protrude 3.43"  
4 slots are .25" wide, 5 slots are .375" wide, and 4 slots are .500" wide  
Mounting holes are on 10.625" centers

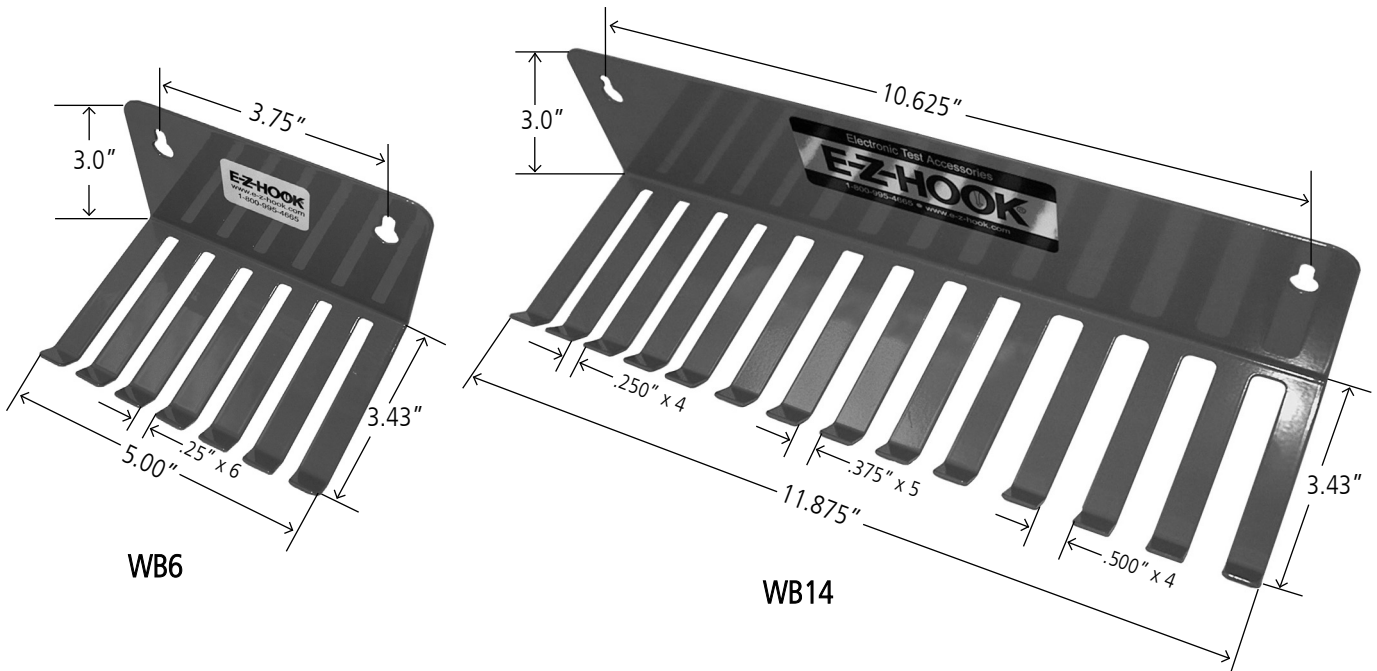

## COLOR-CODING BANDS

Package of 10 or 100 snap-on bands for color-coding coaxial cables. Available in 3 sizes to fit RG174/U cable (.100" (2.54mm) I.D.), RG58C/U cable (.187" (4.7mm) I.D.), and RG59/U cable (.218" (5.5mm) I.D.).

**Color:** Available in 10 Colors.



Part No.	Description
<b>M-100-(color)</b>	For RG174/U Cable

Part No.	Description
<b>M-187-(color)</b>	For RG58C/U Cable

Part No.	Description
<b>M-218-(color)</b>	For RG59C/U Cable

# ACCESSORIES

## E-Z-LIGHT

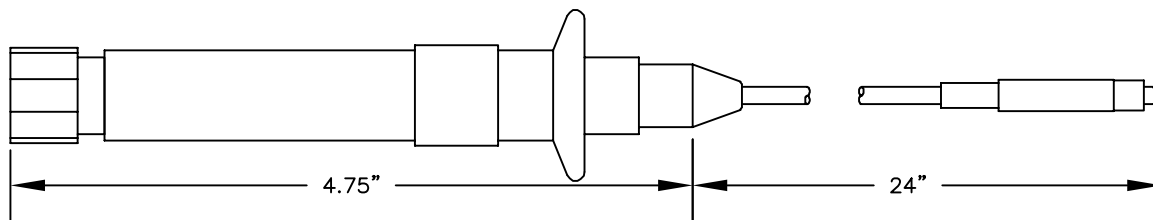

Part No.	Description
SNS-24	E-Z-Light

Fully insulated flexible inspection light for visibility in hard to reach and see areas.  
Length: 24 inches.

## VACUUM HANDLING TOOL

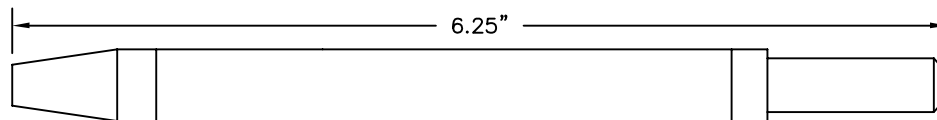

Part Number	Description
X2007	Vacuum Pen with Three Cups
X2007-1	.530" Diameter Cup
X2007-2	.425" Diameter Cup
X2007-3	.210" Diameter Cup

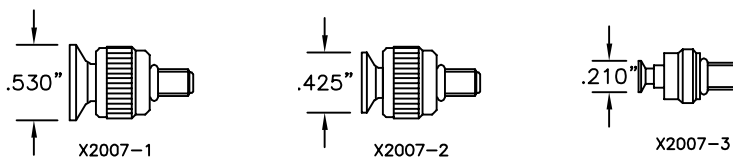

### Features:

- Three different cup sizes included with handle .530" diameter, .425" diameter .210" diameter
- Eliminates need to touch fragile QFP and SOIC packages.
- ESD safe.
- Pick-up weight of 100 grams.

### Vacuum Handling Tool:

This tool allows you to pick and place fine pitch devices with out having to touch them directly by using vacuum pressure to hold the IC to the end of the tool. Choose one of three suction cups that best suit the size IC you are working with. Place the tool, press the plunger down and release. Once installed the device can be moved without fear from bending leads or static electricity damage.

## PLCC EXTRACTION TOOL

Part Number	Description
X2006	Extraction Tool

**Construction:** Two molded nylon finger and thumb pinchers with nickel plated steel extractor hooks.

**Colors:** Available in black only.

### Features:

- Tool is used to extract PLCC packages from their production sockets.
- Utilizes the two corners of a production socket for extracting a PLCC.
- Straight pull prevents bending or breaking of leads.
- Tool will work on PLCC packages with 20, 28, 32, 44, 52, 68, 84, and 100 pin count.

