

Monnit

Wireless Accelerometers



Technical Overview

General Description

The RF Wireless Accelerometer is a digital, low power, low profile, capacitive sensor that is able to measure acceleration on three axes. Four different accelerometer types are available from Monnit.

Features and Principles of Operation

Tilt - Accelerometer activates at a set time interval (defined by user) and converts accelerometer measurements to pitch and roll (0 to 180° -> -180° to 0°). The data is displayed in degrees with 0.1° of resolution.

Example: Pitch: 1.6 Roll: -0.1

G-Force Snapshot - Accelerometer activates at a set time interval (defined by user) and measures g-force along X, Y and Z axes. Primary use is as an inclinometer or tilt sensor. There are three operating modes, ± 2 G, ± 4 G, or ± 8 G. The data is displayed as g-force on each axis.

Example: X: 0.001 Y: 0.031 Z: 1.01

G-Force Max & Avg - Accelerometer samples at 800 Hz over a 10 second period, and reports the measured MAXIMUM value for each axis in g-force and the AVERAGE measured g-force on each axis over the same period, for all three axes. (Only available in the AA version.) This sensor reports in every 10 seconds with this data. Other sampling periods can be configured, down to one second and up to 10 minutes*. The data reported is useful for tracking periodic motion. Sensor data is displayed as Max and average.

*Example: Max X: 0.125 Max Y: 1.012 Max Z: 0.015
Avg X: 0.119 Avg Y: 1.005 Avg Z: 0.007*

* Customer cannot configure sampling period on their own. Contact Monnit to reset the period to be monitored.

Impact Detection - Accelerometer activates when g-forces are exceeded by a user defined threshold – up to 8 g-force. The user can key in the desired threshold for the g-force trigger. This sensor has two operation modes that can be also selected by the user: High Performance and Low Power. High Performance has an output data rate of 800 Hz with the High Pass Filter cutoff at 16 Hz while the Low Power has an output data rate of 12.5 Hz with the High Pass Filter cutoff at 0.25 Hz. The data is displayed as “Force Detected” or “No Force Detected”.

Monnit Sensors Core Specifications

- Power: Replaceable 3.0 V coin cell battery
- Communication: RF 900, 920, 868 and 433 MHz
- Dimensions: 1.775" x 1.040" x 0.785"
- Antenna: 4" wire antenna
- Operating Temperature: -7° to 60°C (20° to 140°F)
- Device Range: 250 - 300 ft. non-line-of-sight*
- Battery Life: At 1 hour heartbeat setting, coin cell battery will last ~ 1-2 years.**

* Actual range may vary depending on environment.

** Battery life is determined by sensor reporting frequency and other variables.

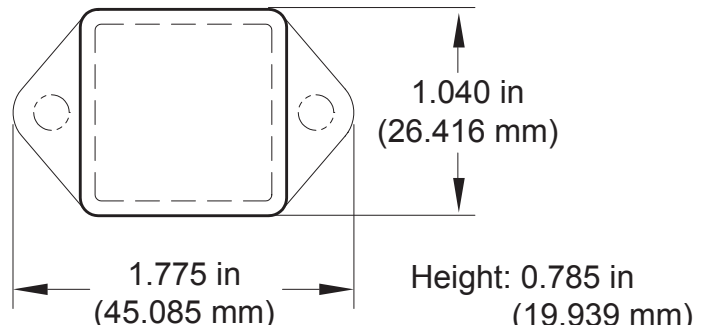

Example Applications

- Inclination & Vibration Testing
- Assembly Line Monitoring
- Smart Machines, Smart Structures & Smart Materials
- Orientation Sensing
- Impact Load Sensing

Power Options

Sensors are powered by a replaceable 3.0 V coin cell battery. Optional AA battery powered sensors are available. The AA version of these sensors are larger in size (3" [L] x 2.1" [W] x 1.2" [H]) and include two long-life AA batteries.

It is recommended that unless you are using the AA battery solution, you set heartbeat to no faster than one hour to preserve battery life.

| Technical Specifications | |
|---|--|
| Supply Voltage | 2.0 - 3.6 VDC * |
| Current Consumption | 0.7 μ A (sleep mode) 2 mA (radio idle/off mode) 2 mA (measurement mode) 25 mA (radio RX mode) 35 mA (radio TX mode) |
| Operating Temperature Range (Board Circuitry and Coin Cell) | -7°C to +60°C (20°F to +140°F)** |
| Optimal Battery Temperature Range (Coin Cell) | +10°C to +50°C (+50°F to +122°F) |
| Sensitivity | 4096 count/g |
| Sensitivity Range Selections | +/-2 G, +/-4 G, +/-8 G |
| Measurement Accuracy | \pm 2.5 % (Force: X, Y, Z) |
| Minimum G Force to Turn On/Wake Up | 0.050 g - 0.100 g |
| Fastest Update Interval/Heart Rate in Any Configuration | Heartbeat: 1 Minute |
| Bandwidth for Data Measurement | 800 Hz |
| Measurement Range (Profile 4 Tilt Only) | 0° to 180° ► -180° to -0° (Rotating in positive direction) |
| Measurement Resolution (Profile 4 Tilt Only) | 0.1° |
| Certifications |  900 MHz product; FCC ID: ZTL- RFSC1 and IC: 9794A-RFSC1. 920 MHz product; ARIB STD-T108 R210-103733. 868 and 433 MHz product tested and found to comply with: CISPR 22:2008-09 / EN 55022:2010 - Class B and ETSI EN 300 220-2 V2.4.1 (2012-05). |

* Hardware can not withstand negative voltage. Please take care when connecting a power device.

** At temperatures above 100°C, it is possible for the board circuitry to lose programmed memory.

| High Performance / Low Power Comparison | | |
|---|---------------------------|---------------------------|
| | High Performance | Low Power |
| Output Data Rate | 800 Hz | 12.5 Hz |
| Noise | Normal | Normal |
| Oversampling Mode | Low Power | Low Power |
| High Pass Filter | ON | ON |
| Dynamic Range | \pm 8 G | \pm 8 G |
| High Pass Filter Cutoff | 16 Hz | 0.25 Hz |
| Transient Detection | X,Y, & Z axis detection | X,Y, & Z axis detection |
| Dynamic Transient Threshold | User Set, 0.063 G – 8.0 G | User Set, 0.063 G – 8.0 G |
| Dynamic Transient Debounce Count | 0 | 0 |

Caution/Notice:

This product is designed for application in an ordinary environment (normal room temperature, humidity and atmospheric pressure). Do not use this sensor under the following conditions as these factors can deteriorate the product characteristics and cause failures and burn-out.: corrosive gas or deoxidizing gas - chlorine gas, hydrogen sulfide gas, ammonia gas, sulfuric acid gas, nitric oxides gas, etc.), volatile or flammable gas, dusty conditions, under low or high pressure, wet or excessively humid locations, places with salt water, oils chemical liquids or organic solvents, where there are excessively strong vibrations, other places where similar hazardous conditions exist.

Use this product within the specified temperature range. Higher temperature may cause deterioration of the characteristics or the material quality of this product.

For more information about our products or to place an order, please contact our sales department at 801-561-5555. Visit us on the web at www.monnit.com.



Monnit Corporation
4403 South 500 West
Murray, UT 84123
801-561-5555
www.monnit.com