

OLED-1

Peripheral Board

Technical Manual

Document Revision: 1.01

Date: 12 October, 2006



BiPOM Electronics

16301 Blue Ridge Road, Missouri City, Texas 77489
Telephone: 1-713-283-9970 Fax: 1-281-416-2806
E-mail: info@bipom.com
Web: www.bipom.com

© 1996-2006 by BiPOM Electronics. All rights reserved.

OLED-1 Peripheral Board Technical Manual. No part of this work may be reproduced in any manner without written permission of BiPOM Electronics.

All trademarked names in this manual are the property of respective owners.

WARRANTY:

BiPOM Electronics warrants OLED-1 board for a period of 1 year. If the board becomes defective during this period, BiPOM Electronics will at its option, replace or repair the board. This warranty is voided if the product is subjected to physical abuse or operated outside stated electrical limits. BiPOM Electronics will not be responsible for damage to any external devices connected to OLED-1. BiPOM Electronics disclaims all warranties express or implied warranties of merchantability and fitness for a particular purpose. In no event shall BiPOM Electronics be liable for any indirect, special, incidental or consequential damages in connection with or arising from the use of this product. BiPOM's liability is limited to the purchase price of this product.

TABLE OF CONTENTS

1. OVERVIEW	3
2. SPECIFICATIONS	4
3. FUNCTIONAL BLOCKS	5
4. BOARD LAYOUT	8
5. SCHEMATIC	9

1. Overview

OLED-1 board is a peripheral board to provide excellent readability and presentation of graphic and text images.

OLED - short for Organic Light-Emitting Diode. OLED displays are unlike LCDs in that they don't require backlighting ; instead, they emit light themselves.

OLED-1 board has built-in 128x64 Single Color Graphic OLED Module.

http://catalog.osram-os.com/media/en/Graphics/00039330_0.pdf

The board directly interface via expansion connector to Single Board Computer (SBC) systems from BiPOM Electronics such as MINI-MAX/ARM, PRO-MAX/51,MINI-MAX/51,MINI-MAX/908.

(<http://www.bipom.com/boards51.php>)

This family of SBC provides all the essential elements of a computer system such as microprocessor, memory, serial port, parallel ports, timers, counters and interrupt handlers on a single chip. The data acquisition system such as logger is a very easy task using these boards.

OLED-1 is powered from 5 Volts DC of external power source through the 20-pin expansion connector.

2. Specifications

OLED-1 board has the following configuration:

- Single operating voltage: 5 VDC, 80 mA maximum supply consumption.
- OS128064PK16MY0A01, 128x64 pixels, single color OLED Display
- 5V-3.3V interface
- 5V to 12V DC/DC converter
- LM2937, 3.3 voltage regulator
- MCP130T-300I/TT voltage supervisor
- Jumper block
- Expansion connector
- OLED Module connector
- OLED Module expansion bus connector, optionally

Dimensions are 2.35 X 2.40 inches (5.97 X 6.10 centimeters).

Mounting holes of 0.138 inches (3.5 millimeters) on four corners.

0° - 70° C operating, -40° - +85° C storage temperature range.

3. Functional Blocks

Figure 1 shows the block diagram of the OLED-1 board.

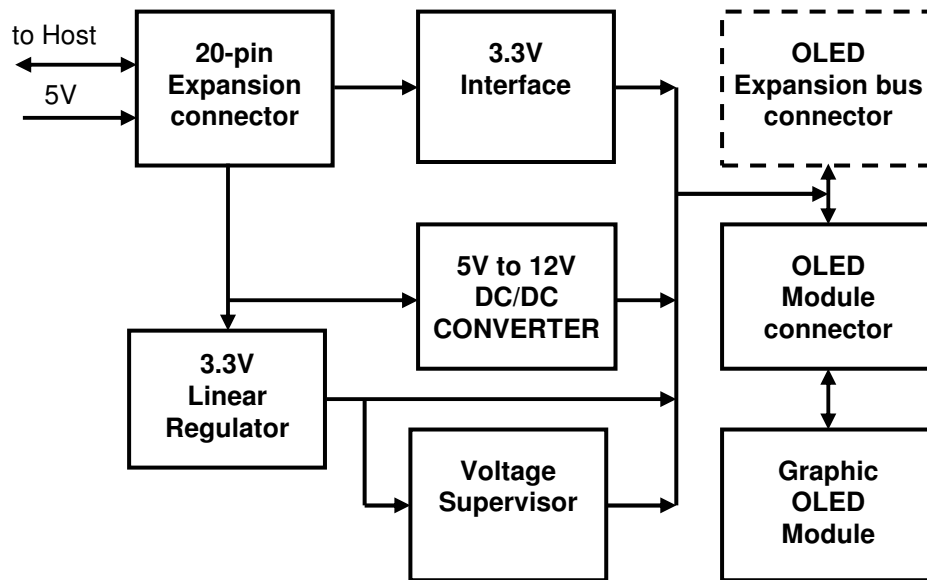

Figure 1

3.3 voltage regulator

OLED-1 has an on-board 3.3 Volt regulator LM2937 (IC2). Logic voltage range of the OLED Module is 2.4-3.5V. The OLED Module is powered from this voltage regulator. The voltage regulator provides 3.3V Logic Power supply for the OLED Module.

3.3 voltage interface

The OLED Module bus operates at voltage range between 2.4 to 3.5 VDC. If the host uses a 5VDC microprocessor/microcontroller, the voltage ranges must be translated between the host and the OLED Module. The SN74CBTD3384DWR chip (IC1) on the board is performing the required task.

3.3 voltage supervisor

The OLED Module bus operates at voltage range between 2.4 to 3.5 VDC. The MCP130T-300 I/TT chip (IC4) on the board is used to keep OLED Module in reset until the system voltage has reached the proper level and stabilized. It also operates as protection from brown-out conditions when the supply voltage drops below a safe operating level.

5V to 12V DC/DC converter

Supply voltage range of the OLED Module is from 12V to 13V. OLED-1 has an on-board 5 Volt to 12 Volt converter LT1301CS8 (IC3) and the OLED Module is powered from this voltage source.

Expansion connector

All the control pins and power supply are available on the 20-pin Expansion connector (X1) to interface to existing SBC boards. OLED-1 peripheral board can be connected either as a piggyback daughter-board to SBC standoffs or it can be placed up away from SBC board using a 20-wire ribbon cable. Table 1 shows the pin assignments for Expansion connector.

Table 1. **Expansion connector (X1)**

Signal	Pin		Pin	Signal
P3.0 (NC)	20		19	P3.1(NC)
P3.2(DC)	18		17	P3.3(NC)
P3.4(SCK)	16		15	P3.5(CS0)
P3.6(CS1)	14		13	P3.7(DIN)
P1.0(NC)	12		11	P1.1
P1.2(NC)	10		9	P1.3(NC)(NC)
P1.4(NC)	8		7	P1.5(NC)
P1.6(NC)	6		5	P1.7(NC)
VCC	4		3	GND
VCC	2		1	GND

Note. NC – not connected on OLED-1 board.

OLED Bus Expansion connector

All the control pins and power supply are available on the 20-pin connector(X2) to interface to Graphic OLED Module. Table 2 shows the pin assignments of the connector.

OLED bus expansion connector is not installed in the base version of the OLED-1 board. This connector can be installed optionally. OLED bus expansion connector pads can be used for testings.

Table 2. **OLED Module connector (X2)**

Signal	Pin		Pin	Signal
VCC 5V	20		19	GND
CS	18		17	RES
BS	16		15	DC
WR	14		13	RD
SCK/D0	12		11	DIN/D1
D2	10		9	D3
D4	8		7	D5
D6	6		5	D7
NC	4		3	VDD 3.3V
VLL 12V	2		1	GND

OLED Module connector

All the control pins and power supply are available on the 18-pin connector(X3) to connect the Graphic OLED Module. Table 3 shows the pin assignments of the connector.

Table 3. OLED Module connector (X3)

Signal	Pin		Pin	Signal
CS	18		9	D3
RES	17		8	D4
BS	16		7	D5
DC	15		6	D6
WR	14		5	D7
RD	13		4	NC
SCK/D0	12		3	VDD 3.3V
DIN/D1	11		2	VLL 12V
D2	10		1	GND

Jumper Block

Jumper block allows to use P3.5, P3.6, or GND as CS signal of the OLED Module.

Table 2 shows the jumper setting.

Table 2. Jumper setting

Signal	Connected	Disconnected
GND	JP1	JP2,JP3
P3.5	JP2	JP1,JP3
P3.6	JP3	JP1,JP2

By default the OLED-1 board is configured to use a serial interface of OLED Module, JP4 jumper is not installed because a PCB wire connects JP4 pads.

In order to use a parallel interface of OLED Module through the OLED bus expansion connector, the PCB wire between JP4 pads should be cut. This action will disconnect BS (pin 16 of X2) signal from ground (GND). The user can select the interface protocol using BS pin:

- Motorola 68 series can be selected connecting BS to GND (or do not cut a wire between JP4 pads);
- Intel 80 series can be selected connecting BS to 3.3V.

Be careful. Not forget to cut a wire between JP4 pads if you select Intel 80 bus.

There are two interface pin out options of OLED module corresponding to the parallel and serial interface requirements. The interface is factory-set by a special jumper on the OLED module. In order to change the interface (serial to parallel) it is necessary to remove the OLED module from the board and move a tiny jumper using a solder iron.

We do not recommend to do that without a special equipment.

The warranty is voided in that case.

Please call (email) BiPOM to provide a parallel version of OLED-1 board.

4. Board Layout

Figure 2 shows positions of major components, connectors and terminals on the OLED-1 board.

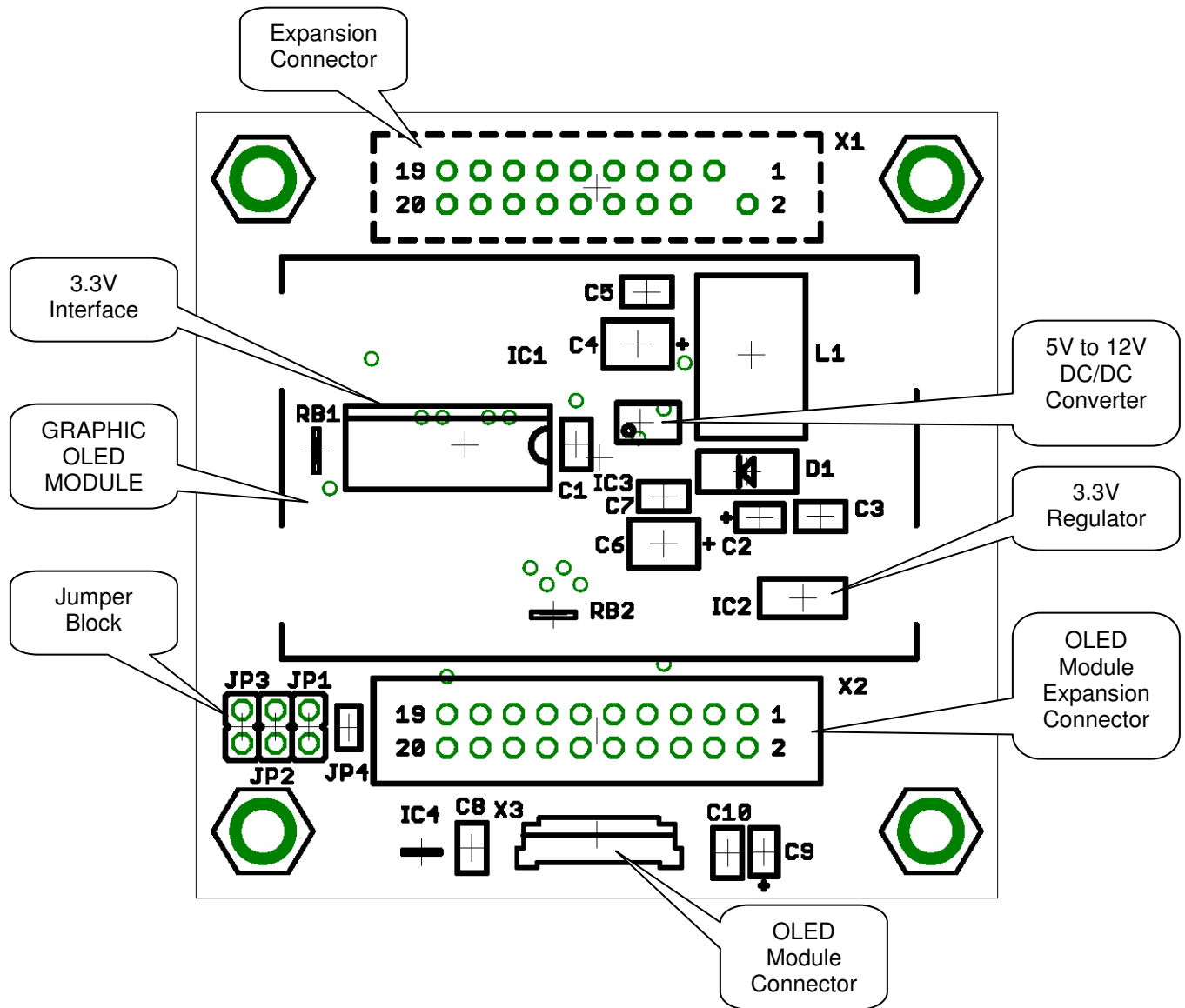
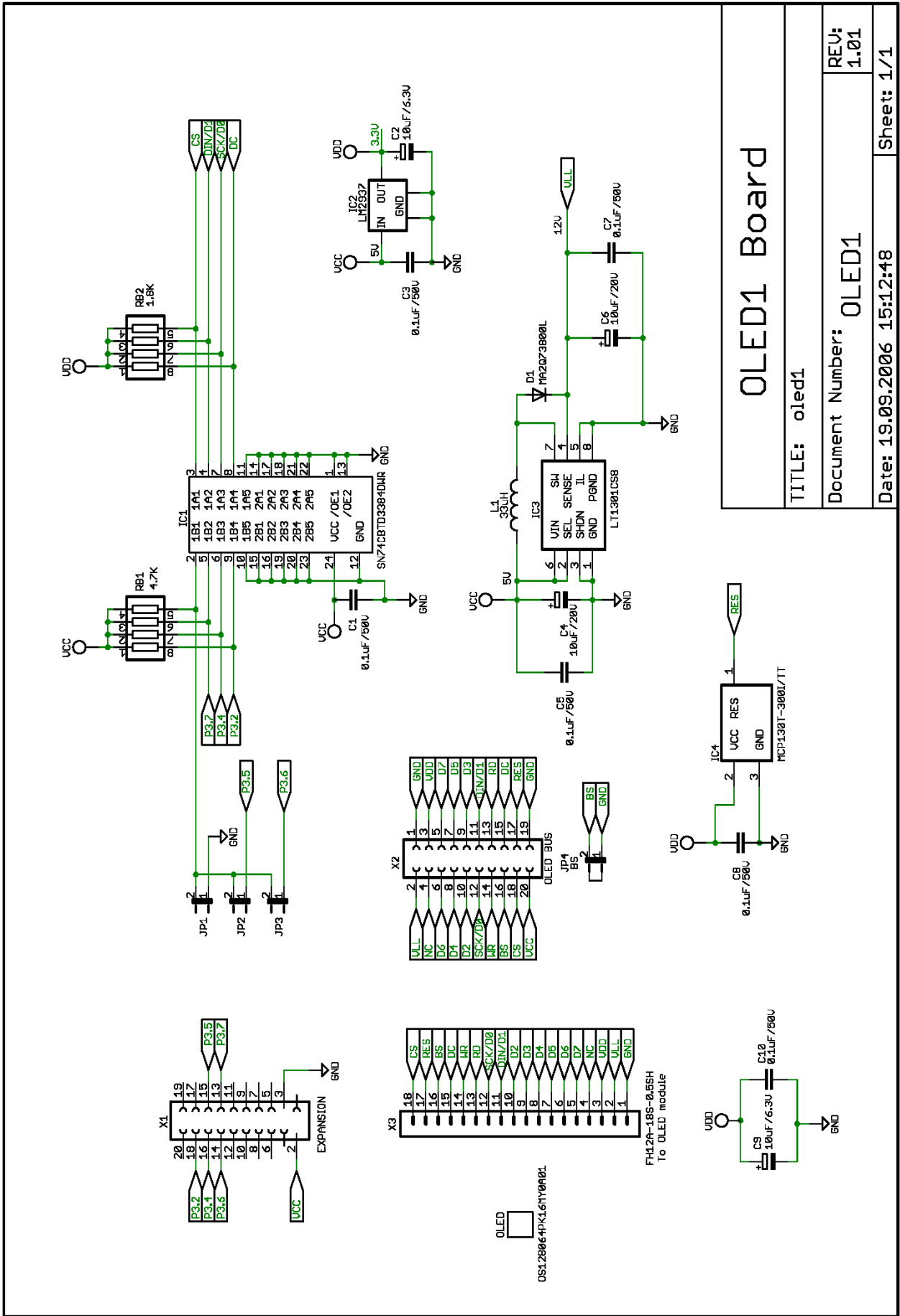

Figure 2

5. Schematic



OLED1 Board	
TITLE: oled1	
Document Number: OLED1	REV: 1.01
Date: 19.09.2006 15:12:48	Sheet: 1/1