

2x75A High Performance Dual Channel Brushless DC Motor Controller with USB, Encoder Inputs and CAN Interface



Roboteq's HBL23xx is a high-current, dual channel controller for hall-sensor equipped Brushless DC motors. The controller uses the position information from the sensors to sequence power on the motors' 3 windings in order to generate smooth continuous rotation. The controller also uses the Hall sensor and/or Encoder information to compute speed and measure travelled distance inside a 32-bit counter. The motors may be operated in open or closed loop speed mode. The HBL23xx features several Analog, Pulse and Digital I/Os which can be remapped as command or feedback inputs, limit switches, or many other function. The HBL23xx accepts commands received from an RC radio, Analog Joystick, wireless modem, or microcomputer. For mobile robot applications, the controller's two motor channels can either be operated independently or mixed to move and steer a vehicle. Using CAN bus, up to 127 controllers can be networked at up to 1Mbit/s on a single twisted pair.

Numerous safety features are incorporated into the controller to ensure reliable and safe operation. The controller's operation can be extensively automated and customized using Basic Language scripts. The controller can be configured, monitored and tuned in realtime using a Roboteq's free PC utility. The controller can also be reprogrammed in the field with the latest features by downloading new operating software from Roboteq.

Applications

- Industrial Automation
- Small Electric Vehicles, Electric Bikes
- Terrestrial and Underwater Robotic Vehicles
- Automatic Guided Vehicles
- Police and Military Robots
- Hazardous Material Handling Robots
- Balancing Robots
- Telepresence Systems
- Animatronics

Key Features

- USB, RS232, 0-5V Analog, or Pulse (RC radio) command modes
- CAN bus interface up to 1Mbit/s
- Auto switch between USB, RS232, Analog, or Pulse based on user-defined priority
- Built-in dual 3-phase high-power drivers for two brushless DC motor at up to 75A
- Trapezoidal switching based on Hall Sensor position information
- Full forward & reverse control on each channel. Four quadrant operation. Supports regeneration
- Operates from a single power source
- Built-in programming language for automation and customization
- Programmable current limit for each channel up to 2x75A for protecting controller, motors, wiring and battery.
- Connector for Hall Sensors
- Accurate speed and Odometry measurement using Hall Sensor data
- Up to 11 Analog Inputs for use as command and/or feedback
- Up to 4 Pulse Length, Duty Cycle or Frequency Inputs for use as command and/or feedback
- Up to 21 Digital Inputs for use as Deadman Switch, Limit Switch, Emergency stop or user inputs
- Dual Quadrature Encoder inputs with 32-bit counters
- 8 general purpose 24V, 1A output for brake release or accessories
- Selectable min, max, center and deadband in Pulse and Analog modes
- Selectable exponentiation factors for each command inputs

- Trigger action if Analog, Pulse or Encoder capture are outside user selectable range (soft limit switches)
- Open loop or closed loop speed control operation
- Closed loop position control with analog or pulse/frequency feedback
- Precise speed and position control when Encoder feedback is used
- PID control loop with separate gains for each channel
- Optional Mixed control (sum and difference) for tank-like steering
- Configurable Data Logging of operating parameters on RS232 Output for telemetry or analysis
- Built-in Battery Voltage and Temperature sensors
- Optional 12V backup power input for powering safely the controller if the main motor batteries are discharged
- Power Control wire for turning On or Off the controller from external microcomputer or switch
- No consumption by output stage when motors stopped
- Regulated 5V output for powering Encoders, RC radio, RF Modem or microcomputer
- Separate Programmable acceleration and deceleration for each motor
- Separate Programmable maximum forward and reverse power
- Support for CANopen and two simplified CAN protocols
- Ultra-efficient 3 mOhm ON resistance MOSFETs
- Auto stop if no motion is detected
- Stall detection and selectable triggered action if Amps is outside user-selected range
- Short circuit protection with selectable sensitivity levels
- Overvoltage and Undervoltage protection
- Programmable Watchdog for automatic motor shutdown in case of command loss
- Overtemperature protection
- Diagnostic LED
- Extruded aluminum, heat sinking enclosure for operation harsh shock and temperature environment
- Efficient heat sinking. Operates without a fan in most applications
- Dustproof and weather resistant. IP51 NEMA rating
- Power wiring via AWG8 battery cables and AWG10 motor cables
- 9" (228.5mm) L, 5.5" W (140mm), 1.6" (40mm) H
- -40o to +85o C operating environment
- 3 lbs (1,350g)
- Easy configuration, tuning and monitory using provided PC utility
- Field upgradeable software for installing latest features via the internet

Orderable Product References

Reference	Number of Channels	Amps/Channel	Volts
HBL2350	2	75	50
HBL2360	2	75	60
HBL2372	2	75	72

Important Safety Disclaimer

Dangerous uncontrolled motor runaway condition can occur for a number of reasons, including, but not limited to: command or feedback wiring failure, configuration error, faulty firmware, errors in user script or user program, or controller hardware failure.

The user must assume that such failures can occur and must make his/her system safe in all conditions. Roboteq will not be liable in case of damage or injury as a result of product misuse or failure.

Power Wires Identifications and Connection

Power connections are made by means of heavy gauge wires located at the back of the controller.

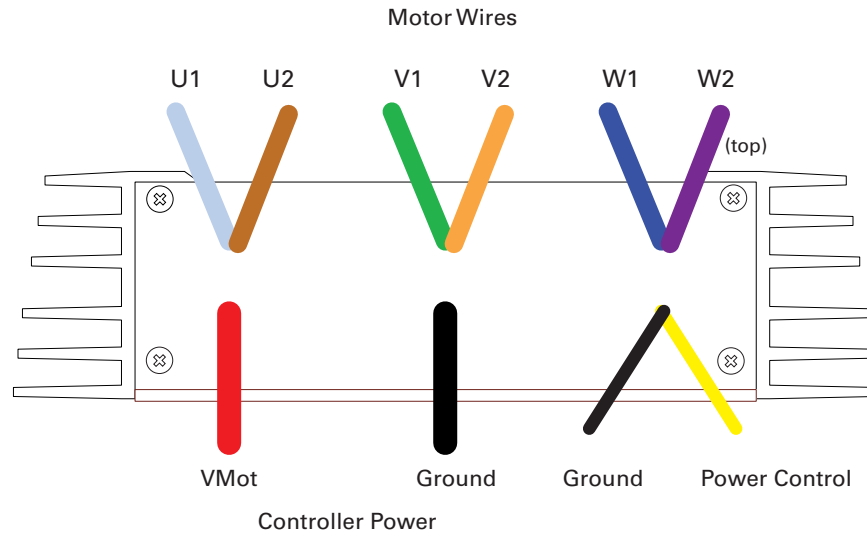

FIGURE 1. Rear Controller Layout

The diagram below shows how to wire the controller and how to turn power On and Off.

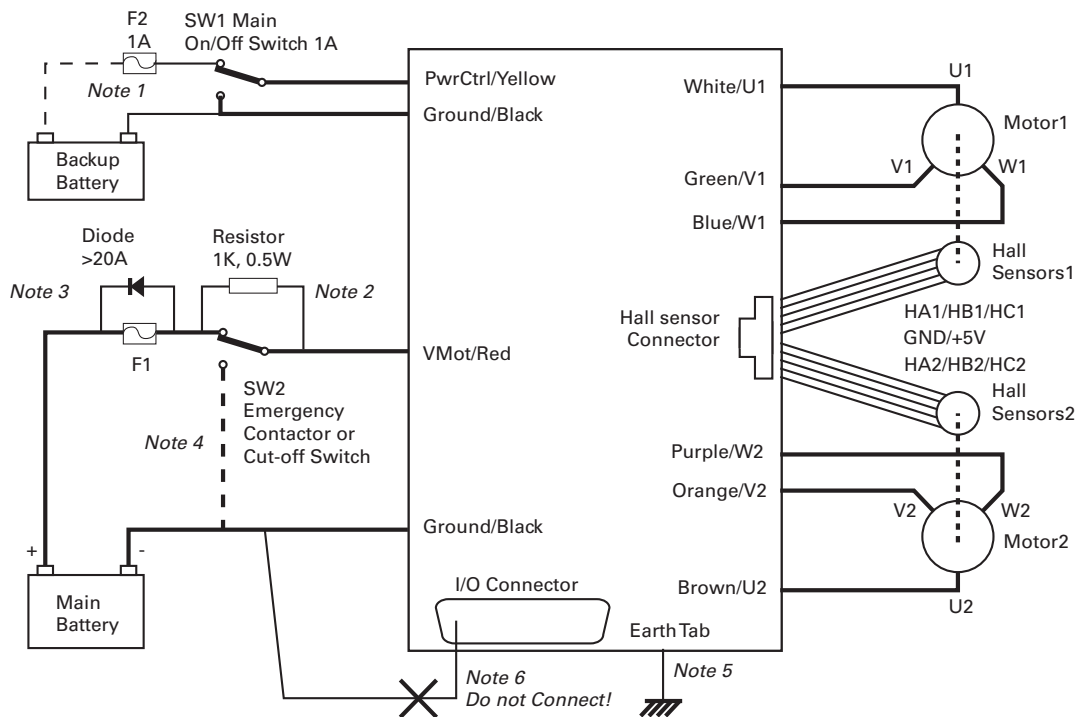

FIGURE 2. Powering the controller. Thick lines identify **MANDATORY** connections

Important Warning

Carefully follow the wiring instructions provided in the Power Connection section of the User Manual. The information on this datasheet is only a summary.

Mandatory Connections

It is imperative that the controller is connected as shown in the above diagram in order to ensure a safe and trouble-free operation. All connections shown as thick black lines are mandatory. The controller must be powered On/Off using switch SW1 on the Yellow wire. Use a suitable high-current fuse F1 as a safety measure to prevent damage to the wiring in case of major controller malfunction.

Emergency Switch or Contactor

The battery must be connected in permanence to the controller's Red wires via a high-power emergency switch or contactor SW2 as additional safety measure. The user must be able to deactivate the switch or contactor at any time, independently of the controller state.

Precautions and Optional Connections

Note 1: Backup battery to ensure motor operation with weak or discharged batteries, connect a second battery to the Power Control wire/terminal via the SW1 switch. For 72V version controllers, the power control and ground connection will only be used as the controller on/off switch. Applying voltage on this line will no longer power on the controller. Some controllers already out in the field will not apply, but all recent purchases made from Roboteq as of 10/2/15 will have this change in effect.

Note 2: Use precharge 1K, 0.5W Resistor to prevent switch arcing.

Note 3: Insert a high-current diode to ensure a return path to the battery during regeneration in case the fuse is blown.

Note 4: Optionally ground the VMot wires when the controller is Off if there is any concern that the motors could be made to spin and generate voltage in excess of 50V (HBL2350), 60V (HBL2360) or 75V (HBL2372).

Note 5: Connect the controller's earth tab to a wire connected to the Earth while the charger is plugged in the AC main, or if the controller is powered by an AC power supply.

Note 6: Beware not to create a path from the ground pins on the I/O connector and the battery minus terminal.

Use of Safety Contactor for Critical Applications

An external safety contactor must be used in any application where damage to property or injury to person can occur because of uncontrolled motor operation resulting from failure in the controller's power output stage.

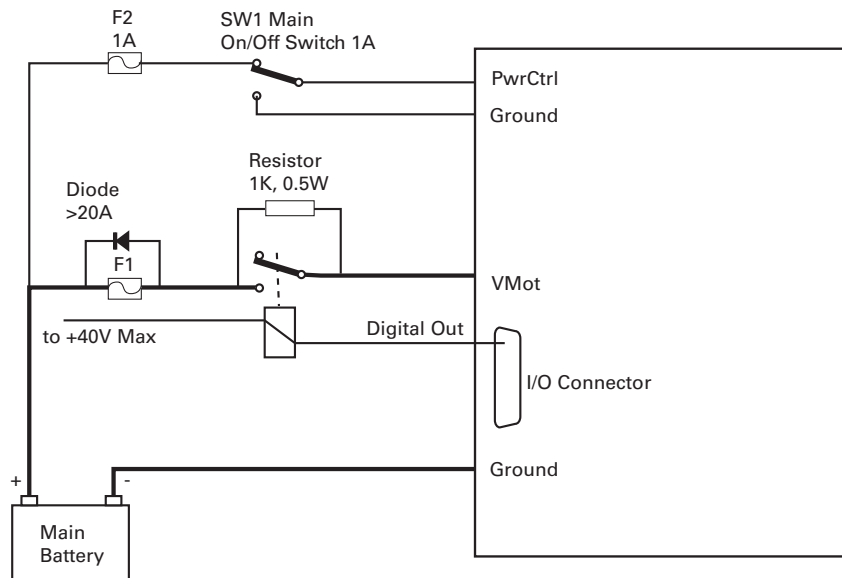

FIGURE 3. Contactor wiring diagram

The contactor coil must be connected to a digital output configured to activate when "No MOSFET Failure." The controller will automatically deactivate the coil if the output is expected to be off and battery current of 1A or more is measured for more than 0.5s. This circuit will not protect against other sources of failure such as those described in the "Important Safety Disclaimer" on page 3.

Controller Mounting

During motor operation, the controller will generate heat that must be evacuated. The published amps rating can only be fully achieved if adequate cooling is provided. Always operate the controller in a well ventilated space so that air can flow between the heatsink fins. Additional conduction cooling can be achieved by having the bottom edges of the case making contact with a metallic surface (chassis, cabinet).

Hall Sensors Connection

Connection to the Hall Sensors is done using a special connector on the front side of the controller. The figure below shows the location of the various low-voltage connectors and LEDs on the controller.

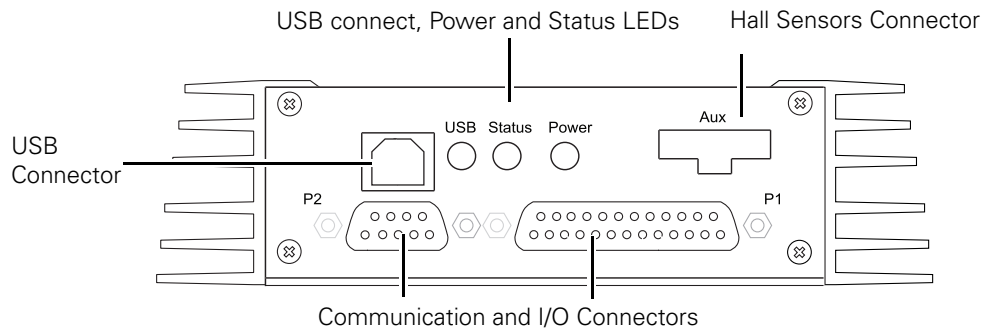

FIGURE 4. Front Controller Layout

The Hall sensor connector is a 10-pin Molex Microfit 3.0, ref. 43025-1000. Pin assignment is in the table below.

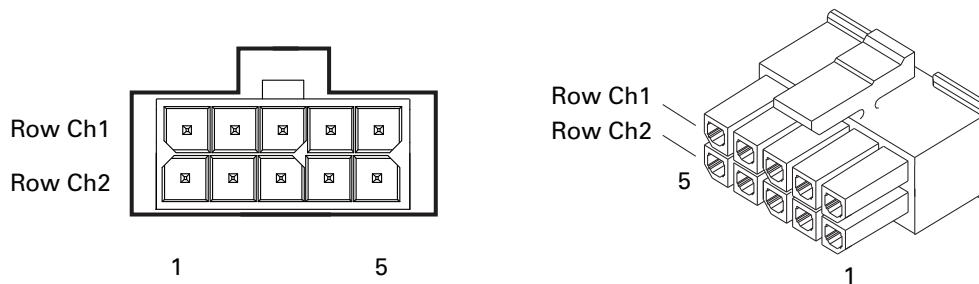

FIGURE 5. Hall Sensors connector

TABLE 1.

Pin Number	1	2	3	4	5
Row Ch1	5V	Hall1 C	Hall1 B	Hall1 A	Ground
Row Ch2	5V	Hall2 C	Hall2 B	Hall2 A	Ground

Hall Sensor vs Motor Output sequencing

The controller requires the Hall sensors inside the motor to be 120 degrees apart. The controller's 3-phase bridge will activate each of the motor winding according to the sequence shown in the figure below.

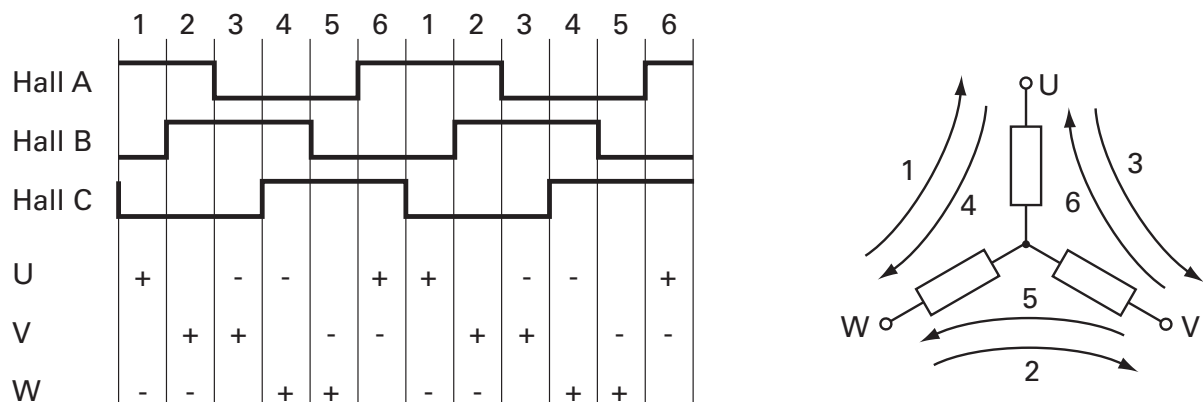

FIGURE 6. Hall Sensors sequence

Commands and I/O Connections

Connection to RC Radio, Microcomputer, Joystick and other low current sensors and actuators is done via the 25 and 9 pin connectors located in front of the connector. The functions of many pins vary depending on controller model and user configuration. Pin assignment is found in the table below.

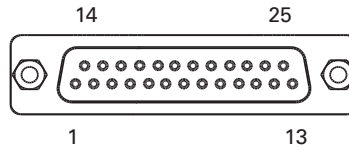

FIGURE 7. Main Connector pin locations

TABLE 2.

Connector Pin	Power	Dout	Com	Pulse	Ana	Dinput	Enc	Default Config
1	GND							
14	5VOut							
2			TxData					RS232Tx
15				RC1	ANA1	DIN1		RCRadio1
3			RxData					RS232Rx
16				RC2	ANA2	DIN2		RCRadio2
4				RC3	ANA3	DIN3		AnaCmd1 (1)
17				RC4	ANA4	DIN4		AnaCmd2 (1)
5	GND							
18		DOUT1				DIN12		Motor Brake 1
6		DOUT2				DIN13		Motor Brake 2
19		DOUT3				DIN14		Contactora
7		DOUT4				DIN15		Unused
20		DOUT5				DIN16		Unused
8		DOUT6				DIN17		Unused
21					ANA5	DIN5		Unused
9	GND							
22					ANA6	DIN6		Unused
10					ANA7	DIN7		Unused
23					ANA8	DIN8	ENC2B	Unused
11					ANA9	DIN9	ENC2A	Unused
24					ANA10	DIN10	ENC1B	Unused
12					ANA11	DIN11	ENC1A	Unused
25	5VOut							
13	GND							

Note 1: Analog command is disabled in factory default configuration.

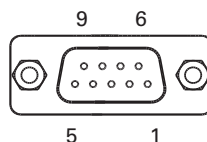

FIGURE 8. Secondary Connector pin locations

TABLE 3.

Connector Pin	Power	Dout	Com	Pulse	Ana	Dinput	Default Config
5		DOUT7				DIN18	Unused
9	5VOut						
4			SCLI				Reserved
8			SDAI				Reserved
3	GND						
7			CANH				CAN High
2			CANL				CAN Low
6	GND						
1		DOUT8				DIN19	Unused

Default I/O Configuration

While the controller can be configured so that practically any Digital, Analog and RC pin can be used for any purpose, the controller's factory default configuration provides an assignment that is suitable for most applications. The figure below shows how to wire the controller to two analog potentiometers, an RC radio, and the RS232 port. It also shows how to connect two outputs to motor brake solenoids and another output to an external status LED. You may omit any connection that is not required in your application. The controller automatically arbitrates the command priorities depending on the presence of a valid command signal in the following order: 1-RS232, 2-RC Pulse, 3-None. If needed, use the Roborun+ PC Utility to change the pin assignments and the command priority order.

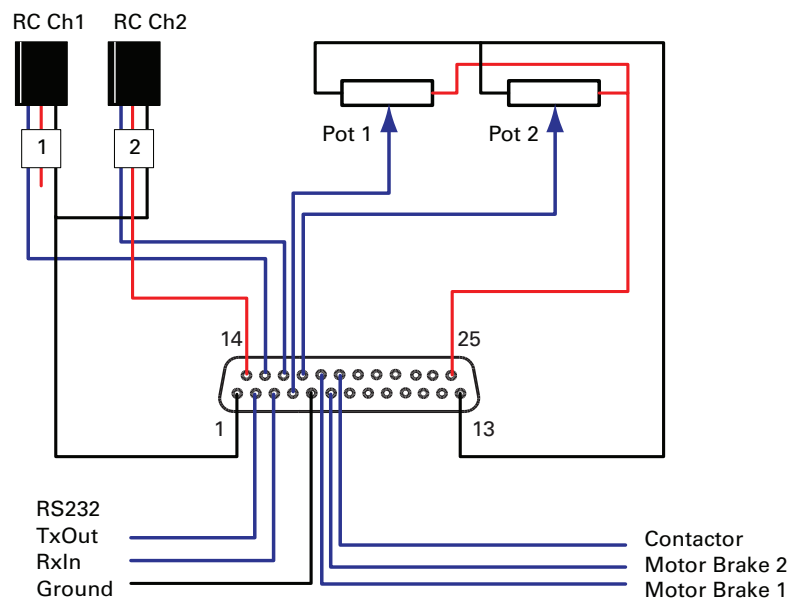

FIGURE 9. Factory default pins assignment

Enabling Analog Commands

For safety reasons, the Analog command mode is disabled by default. To enable the Analog mode, use the PC utility and set Analog in Command Priority 2 or 3 (leave Serial as priority 1). Note that by default the additional securities are enabled and will prevent the motor from starting unless the potentiometer is centered, or if the voltage is below 0.25V or above 4.75V. The drawing shows suggested assignment of Pot 1 to ANA1 and Pot 2 to ANA4. Use the PC utility to enable and assign analog inputs.

USB communication

Use USB only for configuration, monitoring and troubleshooting. USB is not a reliable communication method when used in a electrically noisy environments and communication will not always recover after it is lost without unplugging and replugging the connector, or restarting the controller. Always prefer RS232 communication when interfacing to a computer.

Status LED Flashing Patterns

After the controller is powered on, the Power LED will tun on, indicating that the controller is On. The Status LED will be flashing at a 2 seconds interval. The flashing pattern provides operating or exception status information.

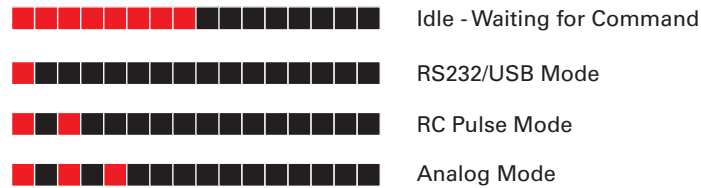

FIGURE 10. Normal Operation Flashing Patterns

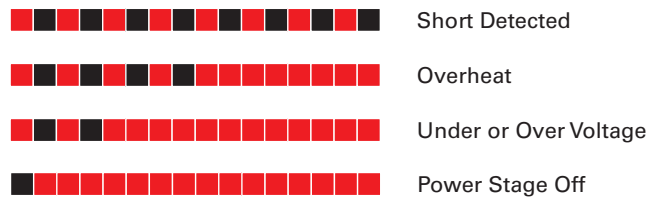

FIGURE 11. Exception or Fault Flashing Patterns

Additional status information may be obtained by monitoring the controller with the PC utility.

Electrical Specifications

Absolute Maximum Values

The values in the table below should never be exceeded, permanent damage to the controller may result.

TABLE 4.

Parameter	Measure point	Models	Min	Typ	Max	Units
Battery Leads Voltage	Ground to VMot	HBL2350			50	Volts
		HBL2360			60	Volts
		HBL2372	36		75	Volts
Reverse Voltage on Battery Leads	Ground to VMot	All	-1			Volts
Power Control Voltage	Ground to Pwr Control wire	All			65	Volts
Motor Leads Voltage	Ground to M1+, M1-, M2+, M2-	HBL2350			50 (1)	Volts
		HBL2360			60 (1)	Volts
		HBL2372	36		75 (1)	Volts

TABLE 4.

Parameter	Measure point	Models	Min	Typ	Max	Units
Digital Output Voltage	Ground to Output pins	All			40	Volts
Analog and Digital Inputs Voltage	Ground to any signal pin on 25 & 9-pin connectors	All			15	Volts
RS232 I/O pins Voltage	External voltage applied to Rx/Tx pins	All			15	Volts
Case Temperature	Case	All	-40		85	oC
Humidity	Case	All			100 (2)	%
Note 1: Maximum regeneration voltage in normal operation. Never inject a DC voltage from a battery or other fixed source						
Note 2: Non-condensing						

Power Stage Electrical Specifications (at 25oC ambient)

TABLE 5.

Continuous Max Current per channel	Measure point	Models	Min	Typ	Max	Units
Battery Leads Voltage	Ground to VMot	HBL2350	0 (1)		50	Volts
		HBL2360	0 (1)		60	Volts
		HBL2372	36 (1)		75	Volts
Motor Leads Voltage	Ground to U, V, W wires	HBL2350	0 (1)		50 (2)	Volts
		HBL2360	0 (1)		60 (2)	Volts
		HBL2372	36 (1)		75 (2)	Volts
Power Control Voltage	Ground to Power Control wire	All	0 (1)		65	Volts
Minimum Operating Voltage	VMot or Pwr Ctrl wires	All	9 (3)			Volts
Over Voltage protection range	Ground to VMot	HBL2350	5	50 (4)	50	Volts
		HBL2360	5	60 (4)	60	Volts
		HBL2372	5	72 (4)	75	Volts
Under Voltage protection range	Ground to VMot	HBL2350	0	5 (4)	50	Volts
		HBL2360	0	5 (4)	60	Volts
		HBL2372	0	5 (4)	75	Volts
Idle Current Consumption	VMot or Pwr Ctrl wires	All	50	100 (5)	150	mA
ON Resistance (Excluding wire resistance)	VMot to U, V or W. Ground to U, V or W	All		6		mOhm
Max Current for 30s	Motor current	All			75 (6)	Amps
Continuous Max Current per channel	Motor current	All			40 (7)	Amps
Current Limit range	Motor current	All	10	50 (8)	75	Amps
Stall Detection Amps range	Motor current	All	10	75 (8)	75	Amps
Stall Detection timeout range	Motor current	All	1	500 (9)	65000	milli-seconds
Short Circuit Detection threshold (10)	Between Motor wires or Between Motor wires and Ground	All	140 (11)		400 (11)	Amps
Short Circuit Detection threshold	Between Motor wires and VMot	All	No Protection. Permanent damage will result			
Motor Acceleration/Deceleration range	Motor Output	All	100	500 (12)	65000	milli-seconds

TABLE 5.

Continuous Max Current per channel	Measure point	Models	Min	Typ	Max	Units
Note 1: Negative voltage will cause a large surge current. Protection fuse needed if battery polarity inversion is possible Note 2: Maximum regeneration voltage in normal operation. Never inject a DC voltage from a battery or other fixed source Note 3: Minimum voltage must be present on VMot or Power Control wire Note 4: Factory default value. Adjustable in 0.1V increments Note 5: Current consumption is lower when higher voltage is applied to the controller's VMot or PwrCtrl wires Note 6: Max value is determined by current limit setting. Duration is estimated and is dependent on ambient temperature cooling condition Note 7: Estimate. Limited by case temperature. Current may be higher with better cooling Note 8: Factory default value. Adjustable in 0.1A increments Note 9: Factory default value. Time in ms that Stall current must be exceeded for detection Note 10: Controller will stop until restarted in case of short circuit detection Note 11: Sensitivity selectable by software Note 12: Factory default value. Time in ms for power to go from 0 to 100%						

Command, I/O and Sensor Signals Specifications

TABLE 6.

Parameter	Measure point	Min	Typ	Max	Units
Main 5V Output Voltage	Ground to 5V pins on	4.6	4.75	4.9	Volts
5V Output Current	5V pins on RJ45 and DSub15			50 (1)	mA
Digital Output Voltage	Ground to Output pins			30	Volts
Digital Output Current	Output pins, sink current			1 (2)	Amps
Output On resistance	Output pin to ground		0.75	1.5	Ohm
Output Short circuit threshold	Output pin	1.05	1.4	1.75	Amps
Input Impedances (except DIN12-19)	AIN/DIN Input to Ground		53		kOhm
Input Impedance (DIN12-19)	Input to 5V		50		kOhm
Digital Input 0 Level	Ground to Input pins	-1		1	Volts
Digital Input 1 Level	Ground to Input pins	3		15	Volts
Analog Input Range	Ground to Input pins	0		5.1	Volts
Analog Input Precision	Ground to Input pins		0.5		%
Analog Input Resolution	Ground to Input pins		1		mV
Pulse durations	Pulse inputs	20000		10	us
Pulse repeat rate	Pulse inputs	50		250	Hz
Pulse Capture Resolution	Pulse inputs		1		us
Frequency Capture	Pulse inputs	100		10000	Hz
Encoder count	Internal	-2.147		2.147	10 ⁹ Counts
Encoder frequency	Encoder input pins			250	kHz
Note 1: Sum of all 5VOut outputs Note 2: Total average current on all outputs not to exceed 4.5A					

Operating & Timing Specifications

TABLE 7.

Parameter	Measure Point	Min	Typ	Max	Units
Command Latency	Command to output change	1	0.5	1	ms
PWM Frequency	Ch1, Ch2 outputs	10	18 (1)	20	kHz
Closed Loop update rate	Internal		1000		Hz
USB Rate	USB pins			12	MBits/s
RS232 baud rate	Rx & Tx pins		115200 (2)		Bits/s
RS232 Watchdog timeout	Rx pin	1 (3)		65000	ms
Note 1: May be adjusted with configuration program					
Note 2: 115200, 8-bit, no parity, 1 stop bit, no flow control					
Note 3: May be disabled with value 0					

Scripting

TABLE 8.

Parameter	Measure Point	Min	Typ	Max	Units
Scripting Flash Memory	Internal		8192		Bytes
Max Basic Language programs	Internal	1000		1500	Lines
Integer Variables	Internal		1024		Words (1)
Boolean Variables	Internal		1024		Symbols
Execution Speed	Internal	50 000	100 000		Lines/s
Note 1: 32-bit words					

Thermal Specifications

TABLE 9.

Parameter	Measure Point	Model	Min	Typ	Max	Units
Case Temperature	Case	All	-40		85 (1)	°C
Thermal Protection range	Case	All	80		90 (2)	°C
Power Dissipation	Case	All			70	Watts
Thermal resistance	Power MOSFETs to case	All			0.6	°C/W
Note 1: Thermal protection will protect the controller power						
Note 2: Max allowed power out starts lowering at minimum of range, down to 0 at max of range						

Mechanical Specifications

TABLE 10.

Parameter	Measure Point	Min	Typ	Max	Units
Weight	Case		1.0 (2.0)		kg (lbs)
Wire Length	Case		17 (43)		inches (mm)

TABLE 10.

Parameter	Measure Point	Min	Typ	Max	Units
Power Wire Gauge	Wire		8		AWG
Power Wire Diameter	Outside diameter		0.26 (6.6)		inches (mm)

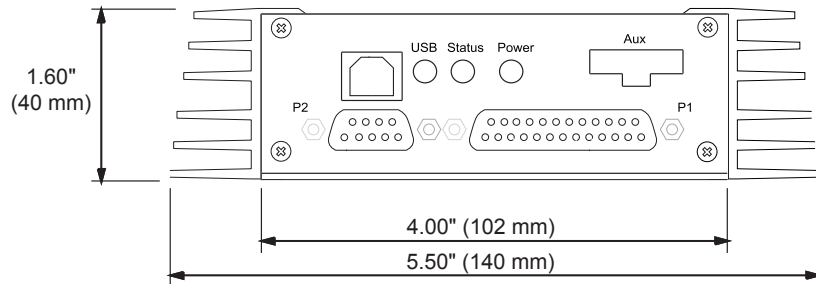

FIGURE 12. HBL23xx front view and dimensions

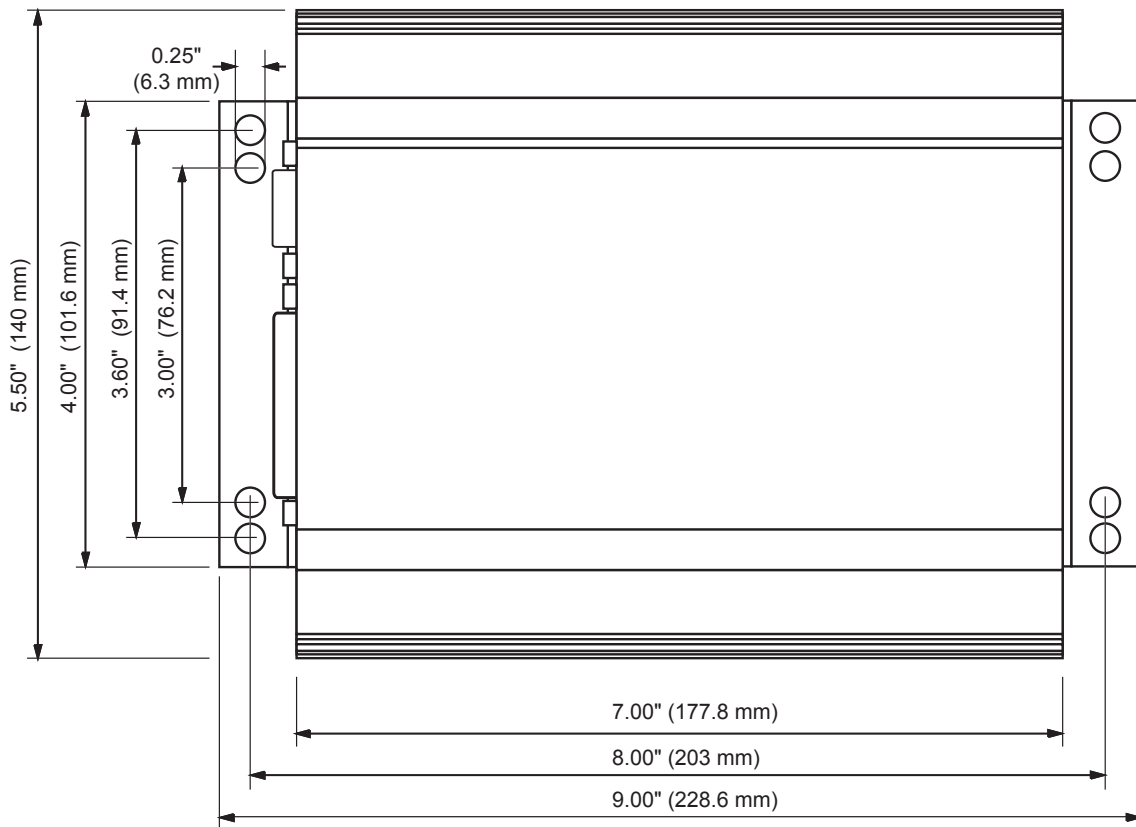

FIGURE 13. HBL23xx top view and dimensions