

2x60A Dual Channel Forward/Reverse Brushed DC Motor Controller



Roboteq's LDC22xx controller is designed to convert commands received from an RC radio, Analog Joystick, wireless modem, PC (via RS232) or microcomputer into high voltage and high current output for driving two DC motors. Designed for maximal ease-of-use, it is delivered with all necessary cables and hardware, and is ready to use in minutes.

The controller features a high-performance 32-bit microcomputer to perform advanced motion control algorithms in Open Loop or Close Loop (Speed or Position) modes. The LDC22xx features several Analog, Pulse and Digital I/Os which can be remapped as command or feedback inputs, limit switches, or many other functions.

The controller's two motor channels can either be operated independently or mixed to set the direction and rotation of a vehicle by coordinating the motion of each motor.

Numerous safety features are incorporated into the controller to ensure reliable and safe operation. The controller's operation can be extensively automated and customized using Basic Language scripts. The controller can be reprogrammed in the field with the latest features by downloading new operating software from Roboteq.

Applications

- Industrial Automation
- Tracking, Pan & Tilt systems
- Terrestrial and Underwater Robotic Vehicles
- Automatic Guided Vehicles
- Police and Military Robots
- Flight simulators
- Telepresence Systems
- Animatronics

Features List

- RS232, 0-5V Analog, or Pulse (RC radio) command modes
- Auto switch between RS232, Analog, or Pulse based on user-defined priority
- Built-in high-power power drivers for two brushed DC motors at up to 60A output per channel
- Full forward & reverse control on each channel. Four quadrant operation. Supports regeneration
- Operates from a single power source
- Built-in programming language for automation and customization
- Programmable current limit for each channel up to 2x60A for protecting controller, motors, wiring and battery
- Up to 4 Analog Inputs for use as command and/or feedback
- Up to 5 Pulse Length, Duty Cycle or Frequency Inputs for use as command and/or feedback
- Up to 6 Digital Inputs for use as Deadman Switch, Limit Switch, Emergency stop or user inputs
- 2 general purpose 24V, 1A output for brake release or accessories
- Selectable min, max, center and deadband in Pulse and Analog modes
- Selectable exponentiation factors for each command inputs
- Trigger action if Analog or Pulse or Encoder capture are outside user selectable range (soft limit switches)
- Open loop or closed loop speed control operation
- Closed loop position control with analog or pulse/frequency feedback
- PID control loop with separate gains for each channel
- Optional Mixed control (sum and difference) for tank-like steering

- Configurable Data Logging of operating parameters on RS232 Output for telemetry or analysis
- Built-in Battery Voltage and Temperature sensors
- Optional 12V backup power input for powering safely the controller if the main motor batteries are discharged
- Power Control wire for turning On or Off the controller from external microcomputer or switch
- No consumption by output stage when motors stopped
- Regulated 5V output for powering RC radio, RF Modem or microcomputer
- Separate Programmable acceleration and deceleration for each motor
- Separate Programmable maximum forward and reverse power
- Ultra-efficient 3 mOhm ON resistance MOSFETs
- Stall detection and selectable triggered action if Amps is outside user-selected range
- Short circuit protection with selectable sensitivity levels
- Overvoltage and Undervoltage protection
- Programmable Watchdog for automatic motor shutdown in case of command loss
- Overtemperature protection
- Diagnostic LED
- Open frame or enclosed design with heat conducting bottom plate
- Efficient heat sinking. Operates without a fan in most applications
- Power wiring via 0.25" Faston tabs
- 5.5" (139.7mm) L, 5.5" W (139.7mm), 1.0" (25mm) H
- -40o to +85o C operating environment
- 0.5 lbs (250g)
- Easy configuration, tuning and monitory using provided PC utility
- Field upgradeable software for installing latest features via the internet

Orderable Product References

TABLE 1.

Reference	Number of Channels	Amps/Channel	Volts
LDC2230	2	60	30
LDC2250	2	60	50

Important Safety Disclaimer

Dangerous uncontrolled motor runaway condition can occur for a number of reasons, including, but not limited to: command or feedback wiring failure, configuration error, faulty firmware, errors in user script or user program, or controller hardware failure.

The user must assume that such failures can occur and must make his/her system safe in all conditions. Roboteq will not be liable in case of damage or injury as a result of product misuse or failure.

Power Wires Identifications and Connection

The diagram below shows how to wire the controller and how to turn power On and Off.

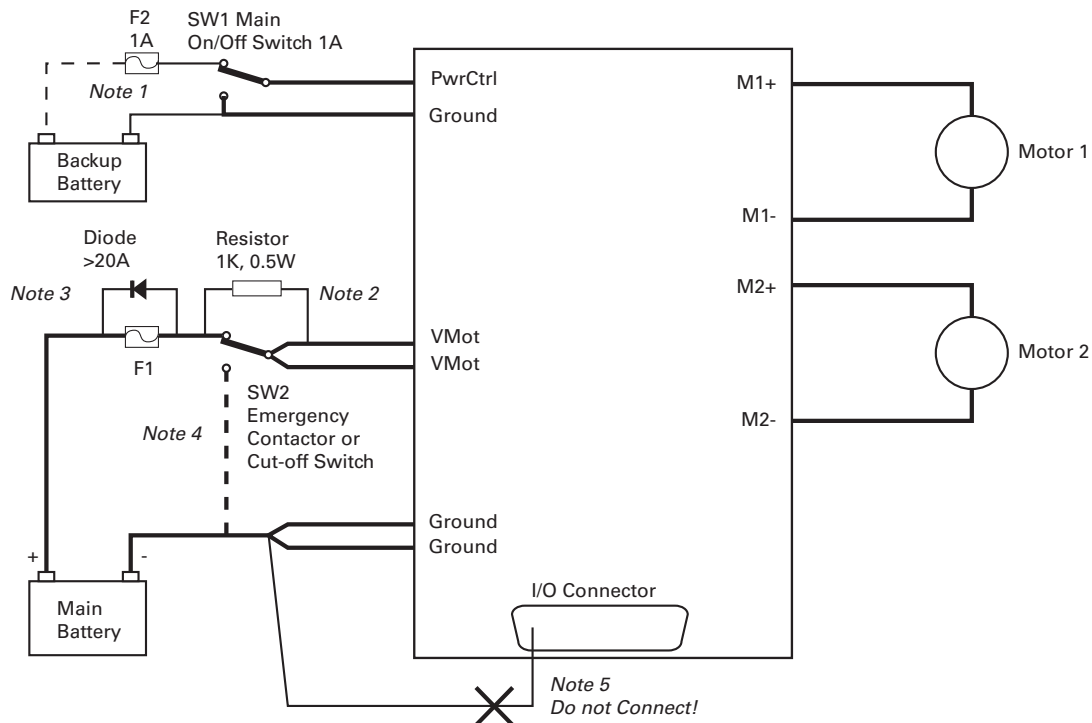

FIGURE 8. Powering the controller. Thick lines identify **MANDATORY** connections

Important Warning

Carefully follow the wiring instructions provided in the Power Connection section of the User Manual. The information on this datasheet is only a summary.

Mandatory Connections

It is imperative that the controller is connected as shown in the above diagram in order to ensure a safe and trouble-free operation. All connections shown as thick black lines are mandatory. The controller must be powered On/Off using switch SW1 on the Power Control Header. Use a suitable high-current fuse F1 as a safety measure to prevent damage to the wiring in case of major controller malfunction.

Emergency Switch or Contactor

The battery must be connected in permanence to the controller's VMot power via an input emergency switch or contactor SW2 as additional safety measure. The user must be able to deactivate the switch or contactor at any time, independently of the controller state.

Precautions and Optional Connections

Note 1: Backup battery to ensure motor operation with weak or discharged batteries, connect a second battery to the Power Control wire/terminal via the SW1 switch.

Note 2: Use precharge 1K, 0.5W Resistor to prevent switch arcing.

Note 3: Insert a high-current diode to ensure a return path to the battery during regeneration in case the fuse is blown.

Note 4: Optionally ground the VMot tabs when the controller is Off if there is any concern that the motors could be made to spin and generate voltage in excess of 30V (LDC2230) or 50V (LDC2250).

Note 5: Beware not to create a path from the ground pins on the I/O connector and the battery minus terminal.

Use of Safety Contactor for Critical Applications

An external safety contactor must be used in any application where damage to property or injury to person can occur because of uncontrolled motor operation resulting from failure in the controller's power output stage.

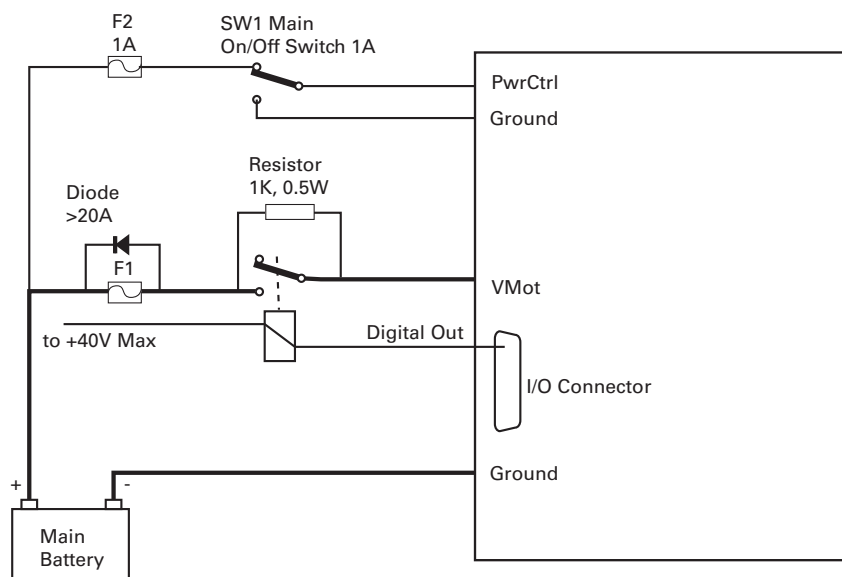

FIGURE 9. Contactor wiring diagram

The contactor coil must be connected to a digital output configured to activate when "No MOSFET Failure". The controller will automatically deactivate the coil if the output is expected to be off and battery current of 1A or more is measured for more than 0.5s. This circuit will not protect against other sources of failure such as those described in the "Important Safety Disclaimer" on page 3.

Controller Mounting

During motor operation, the controller will generate heat that must be evacuated. The published amps rating can only be fully achieved if adequate cooling is provided. Mount the controller so that the bottom plate makes contact with a metallic surface (chassis, cabinet) to conduct the heat.

Commands and I/O Connections

Connection to RC Radio, Microcomputer, Joystick and other low current sensors and actuators is done via the 15 connector located in front of the board. The functions of many pins vary depending on user configuration. Pin assignment is found in the table below.

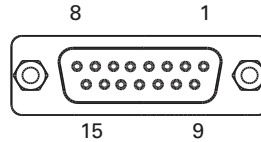

FIGURE 10. Connector pin locations

TABLE 4.

Connector Pin	Power	Dout	Com	RC	Ana	Dinput	Default Config
1		DOUT1					Motor Brake
9		DOUT2					Safety Contactor
2			TxOut				RS232Tx
10				RC5	ANA1	DIN5	AnaCmd1 (1)
3			RxIn				RS232Rx
11				RC4	ANA4	DIN4	AnaCmd2 (1)
4				RC1		DIN1	RCRadio1
12				RC3	ANA3	DIN3	Unused
5	GND						
13	GND						
6			SCL1				Reserved
14	5VOut						
7			SDAI				Reserved
15						DIN6	Unused
8				RC2	ANA2	DIN2	RCRadio2

Note 1: Analog command is disabled in factory default configuration.

Default I/O Configuration

The controller can be configured so that practically any Digital, Analog and RC pin can be used for any purpose. The controller's factory default configuration provides an assignment that is suitable for most applications. The figure below shows how to wire the controller to two analog potentiometers, an RC radio, and the RS232 port. It also shows how to connect the two outputs to motor brake solenoids. You may omit any connection that is not required in your application. The controller automatically arbitrates the command priorities depending on the presence of a valid command signal in the following order: 1-RS232, 2-RC Pulse, 3-None. If needed, use the Roborun+ PC Utility to change the pin assignments and the command priority order.

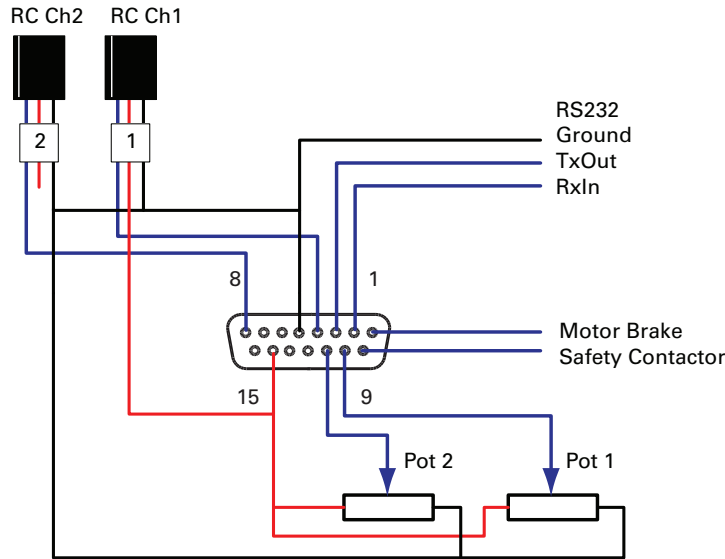

FIGURE 11. Factory default pins assignment

Enabling Analog Commands

For safety reasons, the Analog command mode is disabled by default. To enable the Analog mode, use the PC utility and set Analog in Command Priority 2 or 3 (leave Serial as priority 1). Note that by default the additional securities are enabled and will prevent the motor from starting unless the potentiometer is centered, or if the voltage is below 0.25V or above 4.75V. The drawing shows suggested assignment of Pot 1 to ANA1 and Pot 2 to ANA4. Use the PC utility to enable and assign analog inputs.

Status LED Flashing Patterns

After the controller is powered on, the Power LED will turn on, indicating that the controller is On. The Status LED will be flashing at a 2 seconds interval. The flashing pattern provides operating or exception status information.



FIGURE 12. Normal Operation Flashing Patterns

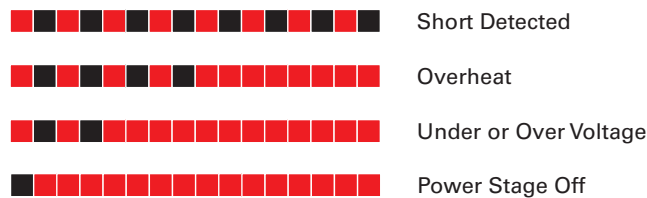

FIGURE 13. Exception or Fault Flashing Patterns

Additional status information may be obtained by monitoring the controller with the PC utility.

Electrical Specifications

Absolute Maximum Values

The values in the table below should never be exceeded, permanent damage to the controller may result.

TABLE 5.

Parameter	Measure point	Model	Min	Typ	Max	Units
Battery Leads Voltage	Ground to VMot	LDC2230			35	Volts
		LDC2250			50	Volts
Reverse Voltage on Battery Leads	Ground to VMot	All	-1			Volts
Power Control Voltage	Ground to Pwr Control wire	All			65	Volts
Motor Leads Voltage	Ground to M1+, M1-, M2+, M2-	LDC2230			30(1)	Volts
		LDC2250			50(1)	Volts
Digital Output Voltage	Ground to Output pins	All			30	Volts
Analog and Digital Inputs Voltage	Ground to any signal pin on 15-pin connectors	All			15	Volts
RS232 I/O pins Voltage	External voltage applied to Rx/Tx pins	All			15	Volts
Temperature	Board	All	-40		85	oC
Humidity	Board	All			100 (2)	%
Note 1: Maximum regeneration voltage in normal operation. Never inject a DC voltage from a battery or other fixed source						
Note 2: Non-condensing						

Power Stage Electrical Specifications (at 25oC ambient)

TABLE 6.

Parameter	Measure point	Model	Min	Typ	Max	Units
Battery Leads Voltage	Ground to VMot	LDC2230	0 (1)		30	Volts
		LDC2250			50	Volts
Motor Leads Voltage	Ground to M1+, M1-, M2+, M2-	LDC2230	0 (1)		30 (2)	Volts
		LDC2250			50 (2)	Volts
Power Control Voltage	Ground to Power Control wire	All	0 (1)		65	Volts
Minimum Operating Voltage	VMot or Pwr Ctrl wires	All	9 (3)			Volts
Over Voltage protection range	Ground to VMot	LDC2230	5	30 (4)	30	Volts
		LDC2250	5	50 (4)	50	Volts
Under Voltage protection range	Ground to VMot	LDC2230	0	5 (4)	30	Volts
		LDC2250	0	5 (4)	50	Volts
Idle Current Consumption	VMot or Pwr Ctrl wires	All	50	100 (5)	150	mA
ON Resistance	VMot to M+, plus M- to Ground at 100% power. Per channel	All		6		mOhm
Max Current per channel for 30s	Motor current	All			60 (6)	Amps
Continuous Max Current per channel	Motor current	All			50 (7)(8)	Amps

TABLE 6.

Parameter	Measure point	Model	Min	Typ	Max	Units
Current Limit range	Ch1 or Ch2 Motor current	All	10	50(9)	60	Amps
Stall Detection Amps range	Ch1 or Ch2 Motor current	All	10	60(9)	60	Amps
Stall Detection timeout range	Ch1 or Ch2 Motor current	All	1	65000 (10)	65000	milli-seconds
Short Circuit Detection threshold (11)	Between Motor wires or Between Motor wire and Ground	All	140 (12)		400 (12)	Amps
Short Circuit Detection threshold	Between Motor wires and VMot	All	No Protection. Permanent damage will result			
Motor Acceleration/Deceleration range	Ch1 or Ch2	All	100	500 (13)	65000	milli-seconds

Note 1: Negative voltage will cause a large surge current. Protection fuse needed if battery polarity inversion is possible
 Note 2: Maximum regeneration voltage in normal operation. Never inject a DC voltage from a battery or other fixed source
 Note 3: Minimum voltage must be present on VMot or Power Control wire
 Note 4: Factory default value. Adjustable in 0.1V increments
 Note 5: Current consumption is lower when higher voltage is applied to the controller's VMot or PwrCtrl wires
 Note 6: Max value is determined by current limit setting. Duration is estimated and is dependent on ambient temperature cooling condition
 Note 7: Current is sum of both synchronized channels. Current must be balanced between channels to obtain max current.
 Note 8: Estimate. Limited by case temperature. Current may be higher with better cooling
 Note 9: Factory default value. Adjustable in 0.5A increments
 Note 10: Factory default value. Time in ms that Stall current must be exceeded for detection
 Note 11: Controller will stop until restarted in case of short circuit detection
 Note 12: Sensitivity selectable by software
 Note 13: Factory default value. Time in ms for power to go from 0 to 100%

Command, I/O and Sensor Signals Specifications

TABLE 7.

Parameter	Measure point	Min	Typ	Max	Units
Main 5V Output Voltage	Ground to 5V pins on DSub15	4.6	4.75	4.9	Volts
5V Output Current	5V pins on DSub15			100	mA
Digital Output Voltage	Ground to Output pins			40	Volts
Digital Output Current	Output pins, sink current			1	Amps
Output On resistance	Output pin to ground		0.75	1.5	Ohm
Output Short circuit threshold	Output pin	1.05	1.4	1.75	Amps
Input Impedances	AIN/DIN Input to Ground		53		kOhm
Digital Input 0 Level	Ground to Input pins	-1		1	Volts
Digital Input 1 Level	Ground to Input pins	3		15	Volts
Analog Input Range	Ground to Input pins	0		5.1	Volts
Analog Input Precision	Ground to Input pins		0.5		%
Analog Input Resolution	Ground to Input pins		1		mV
Pulse durations	Pulse inputs	20000		10	us

TABLE 7.

Parameter	Measure point	Min	Typ	Max	Units
Pulse repeat rate	Pulse inputs	50		250	Hz
Pulse Capture Resolution	Pulse inputs		1		us
Frequency Capture	Pulse inputs	100		10000	Hz

Operating & Timing Specifications

TABLE 8.

Parameter	Measure Point	Min	Typ	Max	Units
Command Latency	Command to output change	0	2.5	5	ms
PWM Frequency	Ch1, Ch2 outputs	10	18 (1)	20	kHz
Closed Loop update rate	Internal		200		Hz
RS232 baud rate	Rx & Tx pins		115200 (2)		Bits/s
RS232 Watchdog timeout	Rx pin	1 (3)		65000	ms
Note 1: May be adjusted with configuration program					
Note 2: 115200, 8-bit, no parity, 1 stop bit, no flow control					
Note 3: May be disabled with value 0					

Scripting

TABLE 9.

Parameter	Measure Point	Min	Typ	Max	Units
Scripting Flash Memory	Internal		2048		Bytes
Max Basic Language programs	Internal		500	750	Lines
Integer Variables	Internal			64	Words (1)
Boolean Variables	Internal			1024	Symbols
Execution Speed	Internal	15 000	30 000		Lines/s
Note 1: 32-bit words					

Thermal Specifications

TABLE 10.

Parameter	Measure Point	Min	Typ	Max	Units
Board Temperature	PCB	-40		85 (1)	oC
Thermal Protection range	PCB	70		80 (2)	oC
Thermal resistance	Power MOSFETs to heats sink			2	oC/W
Note 1: Thermal protection will protect the controller power					
Note 2: Max allowed power out starts lowering at minimum of range, down to 0 at max of range					

Mechanical Specifications

TABLE 11.

Parameter	Measure Point	Min	Typ	Max	Units
Weight	Board		250 (0.5)		g (lbs)
Power Wire Gauge	FASTON tabs			10	AWG

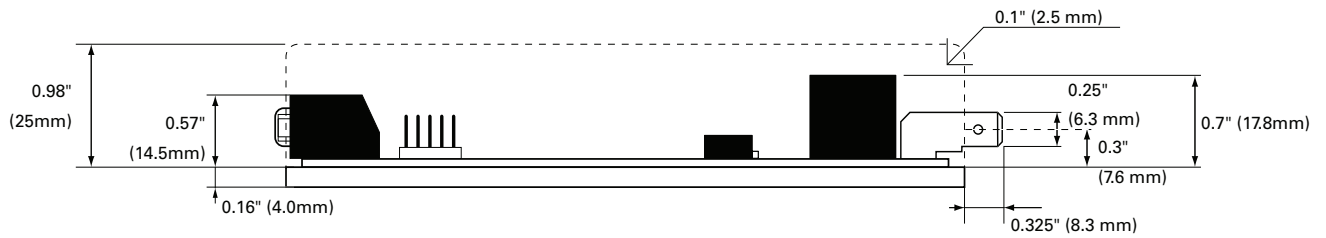

FIGURE 14. LDC22xx side view and dimensions

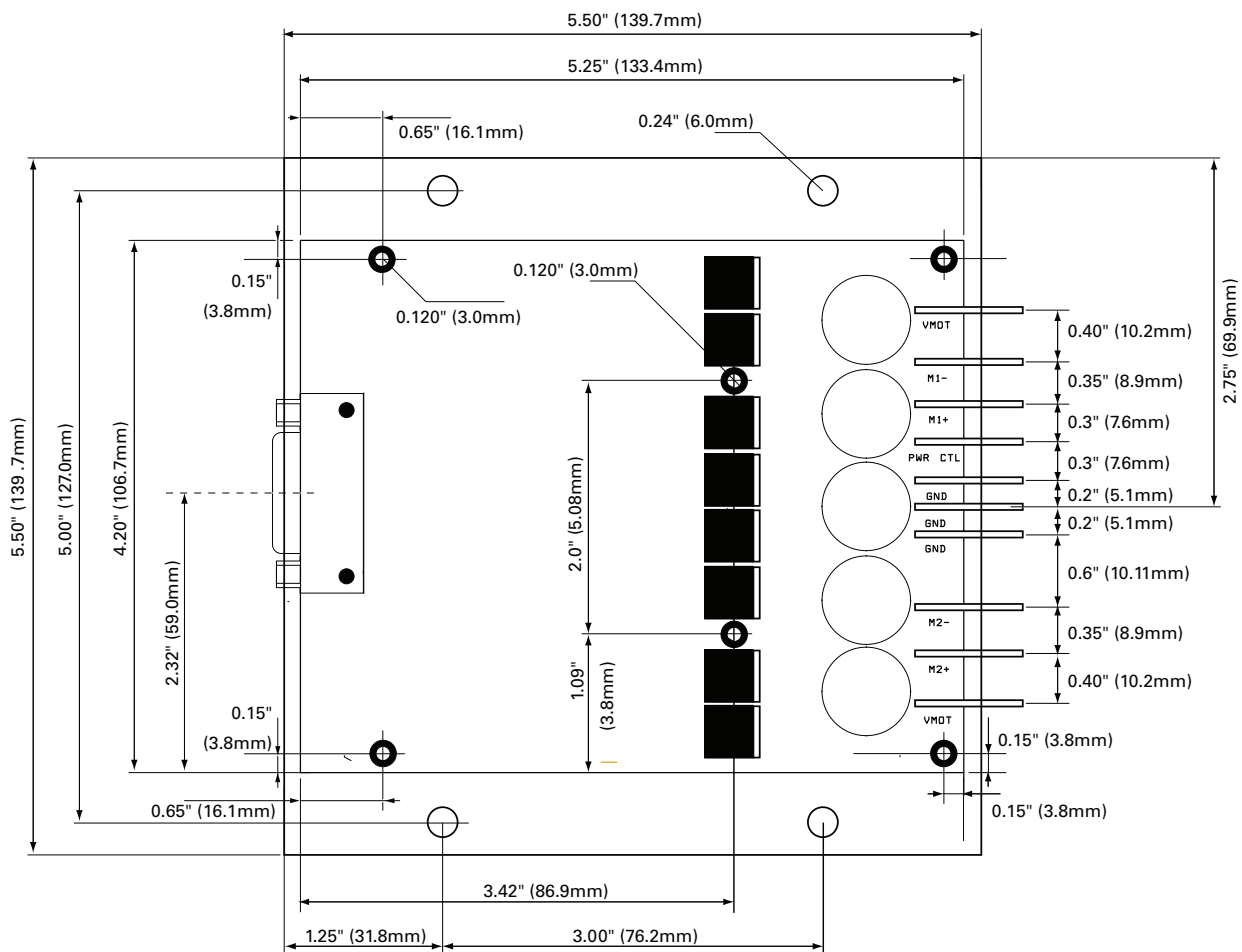

FIGURE 15. LDC22xx top view and dimensions