

Advanced Features Triple Channel 20A Brushed DC Motor Controller with USB and CAN



Roboteq's SDC3260 is a features-packed, high-current, triple channel controller for brushed DC motors. The controller features a high-performance 32-bit microcomputer and quadrature encoder inputs to perform advanced motion control algorithms. The motors may be operated in open or closed loop speed mode, position mode or in torque mode.

The SDC3260 features several Analog, Pulse and Digital I/Os which can be remapped as command or feedback inputs, limit switches, or many other functions. The SDC3260 accepts commands received from an RC radio, Analog Joystick, wireless modem, PLC, or microcomputer. For mobile robot applications, two of the controller's three motor channels can either be operated independently or mixed to move and steer a vehicle. Using CAN bus, up to 127 controllers can be networked at up to 1Mbit/s on a single twisted pair.

Numerous safety features are incorporated into the controller to ensure reliable and safe operation. The controller's operation can be extensively automated and customized using Basic Language scripts. The controller can be configured, monitored and tuned in realtime using a Roboteq's free PC utility. The controller can also be reprogrammed in the field with the latest features by downloading new operating software from Roboteq.

Applications

- Motion simulators
- XYZ platforms
- Underwater Robotic Vehicles
- Stabilization Gimbals
- Machine tools
- Industrial automation
- Telepresence Systems
- Animatronics

Key Features

- USB, RS323, RS485, 0-5V Analog, or Pulse (RC radio) command modes
- CAN bus interface up to 1Mbit/s with multiple protocol support
- Auto switch between Serial, USB, CAN, Analog, or Pulse based on user-defined priority
- Built-in tripple high-power drivers for three brushed DC motor at up to 20A each
- Full forward & reverse motor control. Four quadrant operation. Supports regeneration
- Operates from a single 10V-60V power source
- Programmable current limit up to 20A per motor for protecting controller, motor, wiring and battery
- Separate connectors for 3 quadrature encoders
- Up to 8 Analog Inputs for use as command and/or feedback
- Up to 8 Pulse Length, Duty Cycle or Frequency Inputs for use as command and/or feedback
- Up to 10 Digital Inputs for use as Deadman Switch, Limit Switch, Emergency stop or user inputs
- 4 general purpose 24V, 1.5A output for brake release or accessories
- Selectable min, max, center and deadband in Pulse and Analog modes
- Selectable exponentiation factors for each command inputs
- Trigger action if Analog, Pulse or Encoder counter capture are outside user selectable range (soft limit switches)
- Open loop or closed loop speed control operation
- Closed loop position control with encoder, analog or pulse/frequency feedback
- Torque mode

- PID control loop
- Built-in Battery Voltage and Temperature sensors
- Optional backup power input for powering safely the controller if the main motor batteries are discharged
- Power Control wire for turning On or Off the controller from external microcomputer or switch
- No consumption by output stage when motors stopped
- Regulated 5V output for powering RC radio, RF Modem, sensors or microcomputer
- Separate Programmable acceleration and deceleration for each motor
- Ultra-efficient 9.0 mOhm ON resistance MOSFETs
- Selectable triggered action if Amps is outside user-selected range
- Short circuit protection
- Overvoltage and Undervoltage protection
- Watchdog for automatic motor shutdown in case of command loss
- Overtemperature protection
- Diagnostic LED
- ABS plastic enclosure with heat conducting bottom plate
- Efficient heat sinking. Operates without a fan in most applications.
- Dustproof and weather resistant. IP51 NEMA rating
- Power wiring using screw terminals
- 4.8" (123.0mm) L, 3.3" W (83.0mm), 1.0" (25mm) H
- -40o to +85o C operating environment
- 0.25 lbs (100g)
- Easy configuration, tuning and monitory using provided PC utility
- Field upgradeable software for installing latest features via the internet Orderable Product References

Orderable Product References

Reference	Number of Channels	Amps/Channel	Volts
SDC3260	3	20	60

Important Safety Disclaimer

Dangerous uncontrolled motor runaway condition can occur for a number of reasons, including, but not limited to: command or feedback wiring failure, configuration error, faulty firmware, errors in user script or user program, or controller hardware failure.

The user must assume that such failures can occur and must make his/her system safe in all conditions. Roboteq will not be liable in case of damage or injury as a result of product misuse or failure.

Power Wires Identifications and Connection

Power connections are made by means of screw terminals located at the back of the controller.

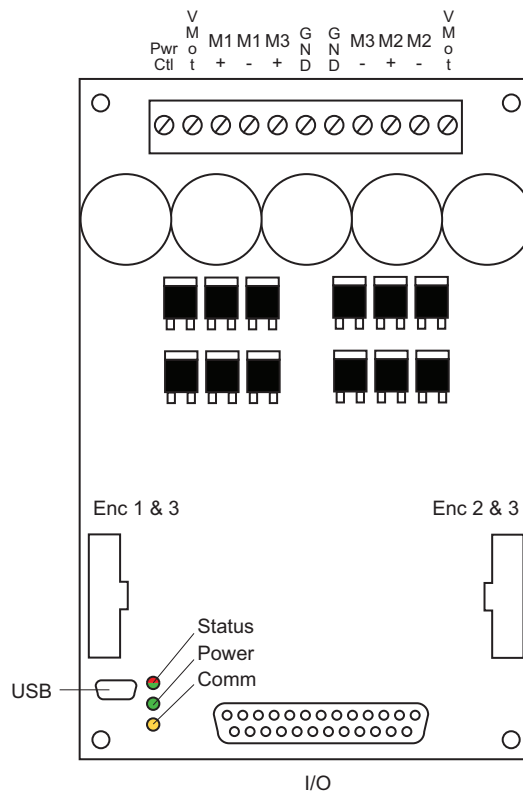

FIGURE 1. SDC3260 outline

The diagram below shows how to wire the controller and how to turn power On and Off.

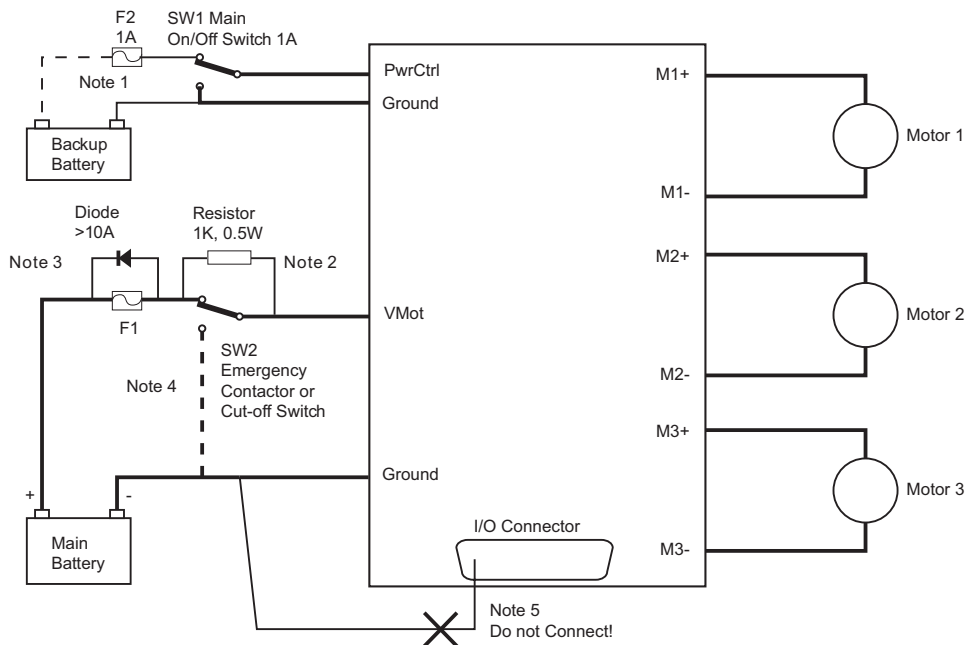

FIGURE 3. Powering the controller. Thick lines identify MANDATORY connections

Important Warning

Carefully follow the wiring instructions provided in the Power Connection section of the User Manual. The information on this datasheet is only a summary.

Mandatory Connections

It is imperative that the controller is connected as shown in the above diagram in order to ensure a safe and trouble-free operation. All connections shown as thick black lines are mandatory. The controller must be powered On/Off using switch SW1 on the Pwr Ctrl terminal. Use a suitable high-current fuse F1 as a safety measure to prevent damage to the wiring in case of major controller malfunction.

Emergency Switch or Contactor

The battery must be connected in permanence to the controller's VMot terminal via a high-power emergency switch or contactor SW2 as additional safety measure. The user must be able to deactivate the switch or contactor at any time, independently of the controller state.

Precautions and Optional Connections

Note 1: Backup battery to ensure motor operation with weak or discharged batteries, connect a second battery to the Power Control wire/terminal via the SW1 switch.

Note 2: Use precharge 1K, 0.5W Resistor to prevent switch arcing.

Note 3: Insert a high-current diode to ensure a return path to the battery during regenera-

tion in case the fuse is blown.

Note 4: Optionally ground the VMot terminal when the controller is Off if there is any concern that the motors could be made to spin and generate voltage in excess of 60V.

Note 5: Connect the controller's bottom plate to a wire connected to the Earth while the charger is plugged in the AC main, or if the controller is powered by an AC power supply.

Note 6: Beware not to create a path from the ground pins on the I/O connector and the battery minus terminal.

Use of Safety Contactor for Critical Applications

An external safety contactor must be used in any application where damage to property or injury to person can occur because of uncontrolled motor operation resulting from failure in the controller's power output stage.

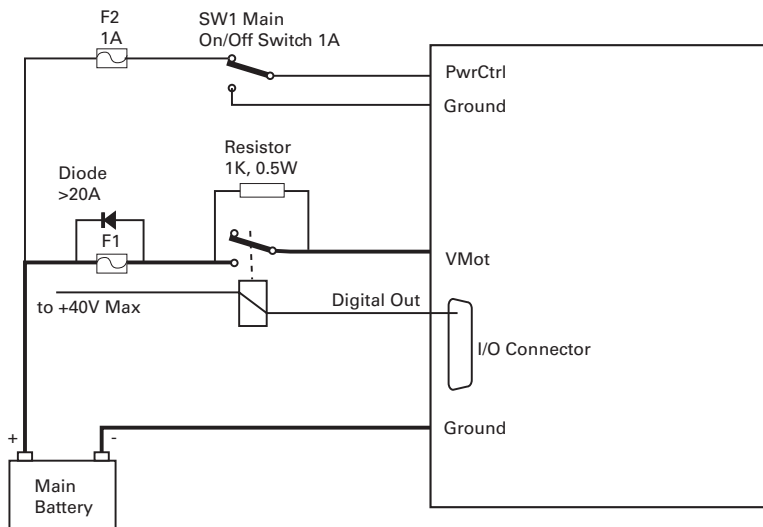

FIGURE 4. Contactor wiring diagram

The contactor coil must be connected to a digital output configured to activate when "No MOSFET Failure". The controller will automatically deactivate the coil if the output is expected to be off and battery current of 1A or more is measured for more than 0.5s. This circuit will not protect against other sources of failure such as those described in the "Important Safety Disclaimer" on page 3.

Controller Mounting

During motor operation, the controller will generate heat that must be evacuated. The published amps rating can only be fully achieved if adequate cooling is provided. Good conduction cooling can be achieved by having the bottom edges of the case making contact with a metallic surface (chassis, cabinet).

Encoder Connection

Connection to the Encoders is done using two special connectors on the front side of the controller. The connectors are 6-pin Molex Microfit 3.0, ref. 43645. . Pin assignment is in the table below.

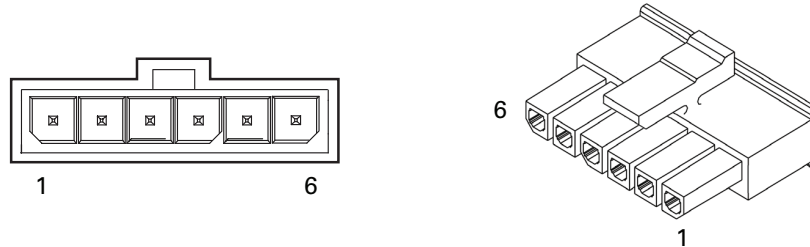

FIGURE 5. Encoder connector

TABLE 1.

Pin Number	1	2	3	4	5	6
Connector 1	5V	NC	Enc3 A	Enc1 B	Enc1 A	GND
Connector 2	5V	NC	Enc3 B	Enc2 B	Enc2 A	GND

Commands and I/O Connections

Connection to RC Radio, Microcomputer, Joystick and other low current sensors and actuators is done via the 25 connector. The functions of many pins vary depending on controller model and user configuration. Pin assignment is found in the table below.

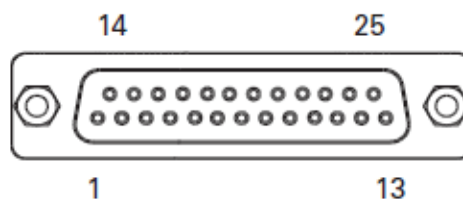

FIGURE 6. Main Connector pin locations

TABLE 2.

Connector Pin	Power	Dout	Com	Pulse	Ana	Dinput	Default Config
1	GND						
14	5VOut						
2			RSTxD				RS232Tx
15				RC1	ANA1	DIN1	RCRadio1
3			RS RxD				RS232Rx
16				RC2	ANA2	DIN2	RCRadio2
4				RC3	ANA3	DIN3	AnaCmd1 (1)
17				RC4	ANA4	DIN4	AnaCmd2 (1)

TABLE 2.

Connector Pin	Power	Dout	Com	Pulse	Ana	Dinput	Default Config
5	GND						
18		DOUT1					Motor Brake 1
6		DOUT2					Motor Brake 2
19		DOUT3					Contactora
7		DOUT4					Unused
20			CANH				Unused
8			CANL				Unused
21				RC5	ANA5	DIN5	Unused
9						DIN9	Unused
22				RC6	ANA6	DIN6	Unused
10						DIN10	Unused
23			RS485A				RS485
11			RS485B				RS485
24				RC7	ANA7	DIN7	Unused
12				RC8	ANA8	DIN8	Unused
25	5VOut						
13	GND						

Note 1: Analog command is disabled in factory default configuration.

Default I/O Configuration

While the controller can be configured so that practically any Digital, Analog and RC pin can be used for any purpose, the controller's factory default configuration provides an assignment that is suitable for most applications. The figure below shows how to wire the controller to two analog potentiometers, an RC radio, and the RS232 port. It also shows how to connect two outputs to motor brake solenoids and another output to an external status LED. You may omit any connection that is not required in your application. The controller automatically arbitrates the command priorities depending on the presence of a valid command signal in the following order: 1-RS232, 2-RC Pulse, 3-None. If needed, use the Roborun+ PC Utility to change the pin assignments and the command priority order.

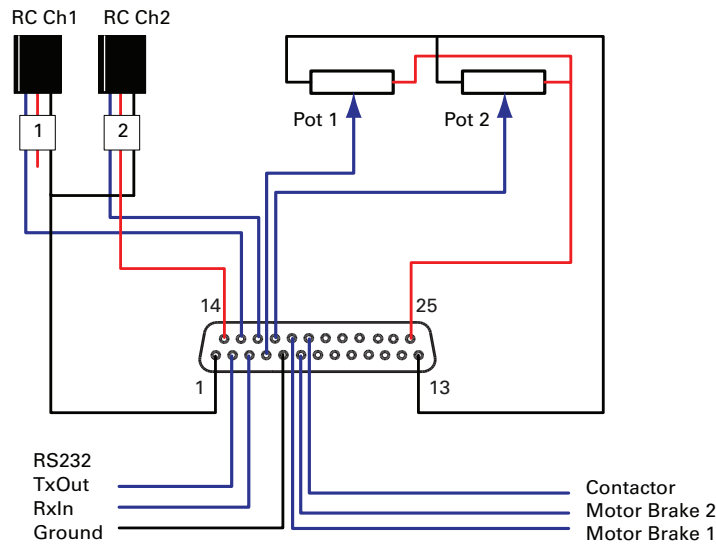

FIGURE 7. Factory default pins assignment

Enabling Analog Commands

For safety reasons, the Analog command mode is disabled by default. To enable the Analog mode, use the PC utility and set Analog in Command Priority 2 or 3 (leave Serial as priority 1). Note that by default the additional securities are enabled and will prevent the motor from starting unless the potentiometer is centered, or if the voltage is below 0.25V or above 4.75V. The drawing shows suggested assignment of Pot 1 to ANA1 and Pot 2 to ANA4. Use the PC utility to enable and assign analog inputs.

USB communication

Use USB only for configuration, monitoring and troubleshooting. USB is not a reliable communication method when used in a electrically noisy environments and communication will not always recover after it is lost without unplugging and replugging the connector, or restarting the controller. Always prefer RS232 communication when interfacing to a computer. USB and CAN can operate at the same time on the SDC3260. Plugging USB to a computer will not disable the CAN interface.

Status LEDs and Flashing Patterns

The controller is equipped with 3 LEDs. A Green Power LED, a Red/Green Status LED, and a Yellow Communication LED.

After the controller is powered on, the Power LED will tun on, indicating that the controller

is On. The Status LED will be flashing at a 2 seconds interval. The flashing pattern and color provides operating or exception status information.

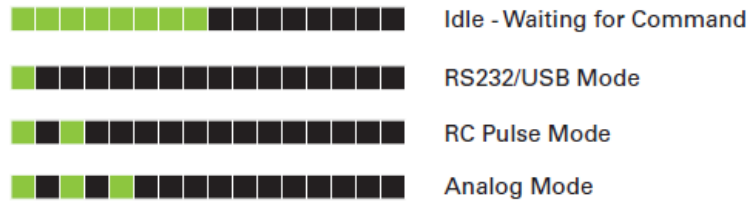

FIGURE 8. Normal Operation Flashing Patterns

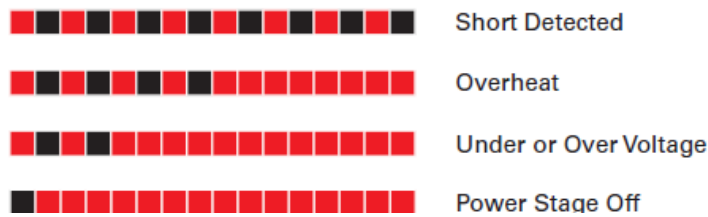

FIGURE 9. Exception or Fault Flashing Patterns

Additional status information may be obtained by monitoring the controller with the PC utility.

The communication LED gives status information on the CAN and USB.

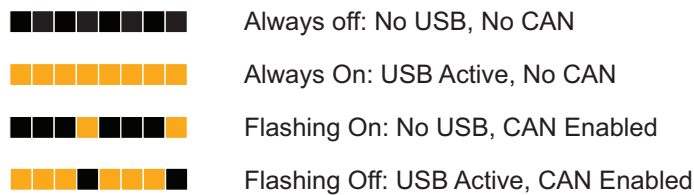

FIGURE 10. Communication LED Flashing Patterns

Electrical Specifications

Absolute Maximum Values

The values in the table below should never be exceeded, permanent damage to the controller may result.

TABLE 3.

Parameter	Measure point	Min	Typ	Max	Units
Battery Leads Voltage	Ground to VBat			63	Volts
Reverse Voltage on Battery Leads	Ground to VBat	-1			Volts

TABLE 3.

Parameter	Measure point	Min	Typ	Max	Units
Power Control Voltage	Ground to Pwr Control wire			63	Volts
Motor Leads Voltage	Ground to M+ and M- wires			63 (1)	Volts
Digital Output Voltage	Ground to Output pins			30	Volts
Analog and Digital Inputs Voltage	Ground to any signal pin on 15-pin & Encoder inputs			30	Volts
RS232 I/O pins Voltage	External voltage applied to Rx pin (2)			30	Volts
Case Temperature	Case	-40		85	oC
Humidity	Case			100 (3)	%
<p>Note 1: Maximum regeneration voltage in normal operation. Never inject a DC voltage from a battery or other fixed source</p> <p>Note 2: No external voltage must ever be applied to Tx pin</p> <p>Note 3: Non condensing</p>					

Power Stage Electrical Specifications (at 25oC ambient)

TABLE 4.

Continuous Max Current per channel	Measure point	Min	Typ	Max	Units
Battery Leads Voltage	Ground to VMot	0 (1)		63	Volts
Motor Leads Voltage	Ground to M+ and M- wires	0 (1)		63 (2)	Volts
Power Control Voltage	Ground to Power Control wire	0 (1)		65	Volts
Minimum Operating Voltage	VMot or Pwr Ctrl wires	9 (3)			Volts
Over Voltage protection range	Ground to VMot	5	60 (4)	63	Volts
Under Voltage protection range	Ground to VMot	0	5 (4)	63	Volts
Idle Current Consumption	VMot or Pwr Ctrl wires	50	100 (5)	150	mA
ON Resistance (Excluding wire resistance)	VMot to M+/- . Ground to M+/-		9.0		mOhm
Max Current for 30s	Motor current			20	Amps
Continuous Max Current per channel	Motor current			15(6)	Amps
Current Limit range	Motor current	2	20 (7)	20	Amps
Stall Detection Amps range	Motor current	2	20 (7)	20	Amps
Stall Detection timeout range	Motor current	1	500 (8)	65000	milli-seconds
Short Circuit Detection threshold (9)	Between Motor wires or Between Motor wires and Ground			100 (10)	Amps
Short Circuit Detection threshold	Between Motor wires and VBat	No Protection. Permanent damage will result			

TABLE 4.

Continuous Max Current per channel	Measure point	Min	Typ	Max	Units
Motor Acceleration/ Deceleration range	Motor Output	100	500 (11)	65000	milli-seconds
Note 1: Negative voltage will cause a large surge current. Protection fuse needed if battery polarity inversion is possible Note 2: Maximum regeneration voltage in normal operation. Never inject a DC voltage from a battery or other fixed source Note 3: Minimum voltage must be present on VBat or Power Control wire Note 4: Factory default value. Adjustable in 0.1V increments Note 5: Current consumption is lower when higher voltage is applied to the controller's VBat or PwrCtrl wires Note 6: Estimate. Limited by case temperature. Current may be higher with better cooling Note 7: Factory default value. Adjustable in 0.1A increments Note 8: Factory default value. Time in ms that Stall current must be exceeded for detection Note 9: Controller will stop until restarted in case of short circuit detection Note 10: Approximate value Note 11: Factory default value. Time in ms for power to go from 0 to 100%					

Command, I/O and Sensor Signals Specifications

TABLE 5.

Parameter	Measure point	Min	Typ	Max	Units
Main 5V Output Voltage	Ground to 5V pins on	4.6	4.75	4.9	Volts
5V Output Current	5V pins on RJ45 and DSub15			200 (1)	mA
Digital Output Voltage	Ground to Output pins			30	Volts
Output On resistance	Output pin to ground		0.25	0.5	Ohm
Output Short circuit threshold	Output pin	1.7		3.5	Amps
Digital Output Current	Output pins, sink current			1.5	Amps
Input Impedances	AIN/DIN Input to Ground		53		kOhm
Digital Input 0 Level	Ground to Input pins	-1		1	Volts
Digital Input 1 Level	Ground to Input pins	3		30	Volts
Analog Input Range	Ground to Input pins	0		5.1	Volts
Analog Input Precision	Ground to Input pins		0.5		%
Analog Input Resolution	Ground to Input pins		1		mV
Pulse durations	Pulse inputs	20000		10	us
Pulse repeat rate	Pulse inputs	50		250	Hz
Pulse Capture Resolution	Pulse inputs		1		us
Frequency Capture	Pulse inputs	100		10000	Hz
Note 1: Sum of all 5VOut outputs					

Operating & Timing Specifications

TABLE 6.

Parameter	Measure Point	Min	Typ	Max	Units
Command Latency	Command to output change	1	0.5	1	ms
PWM Frequency	Motor Output	10	18	20	kHz
Closed Loop update rate	Internal		1000		Hz
RS232 baud rate	Rx & Tx pins		115200 (1)		Bits/s
RS232 Watchdog timeout	Rx pin	1 (2)		65000	ms
Note 1: 115200, 8-bit, no parity, 1 stop bit, no flow control					
Note 2: May be disabled with value 0					

Scripting

TABLE 7.

Parameter	Measure Point	Min	Typ	Max	Units
Scripting Flash Memory	Internal		16384		Bytes
Max Basic Language programs	Internal	1000		1500	Lines
Integer Variables	Internal		1024		Words (1)
Boolean Variables	Internal		1024		Symbols
Execution Speed	Internal	50 000	100 000		Lines/s
Note 1: 32-bit words					

Thermal Specifications

TABLE 8.

Parameter	Measure Point	Min	Typ	Max	Units
Case Temperature	Case	-40		85 (1)	oC
Thermal Protection range	Case	80		90 (2)	oC
Power Dissipation	Case			70	Watts
Thermal resistance	Power MOSFETs to case			0.6	oC/W
Humidity	Case			100(3)	%
Note 1: Thermal protection will protect the controller power					
Note 2: Max allowed power out starts lowering at minimum of range, down to 0 at max of range					

Mechanical Specifications

TABLE 9.

Parameter	Measure Point	Min	Typ	Max	Units
Weight	Case		250 (0,5)		g (lbs)
Power Connectors Wiring	Screw terminals	14		22	AWG

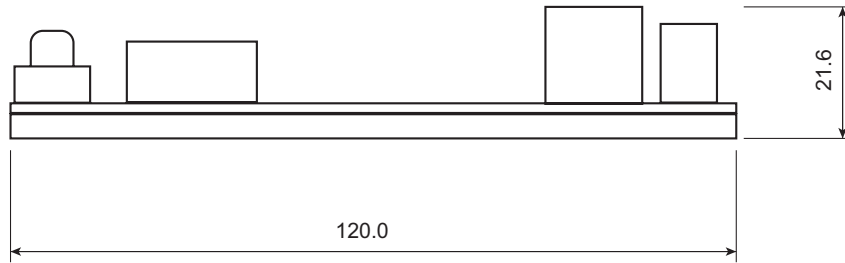

FIGURE 11. SDC3260 side view and dimensions

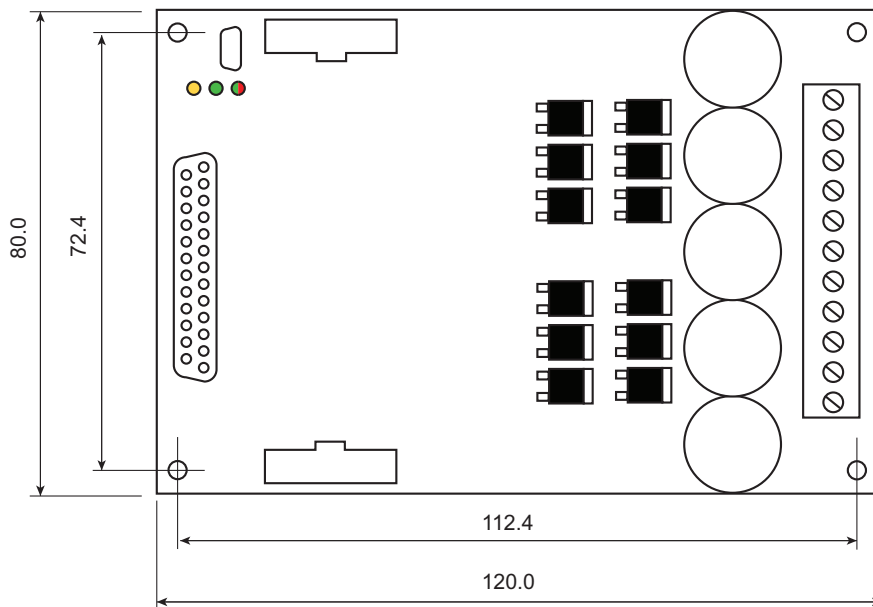

FIGURE 12. SDC3260 top view and dimensions