

## 500A + 25A DC Motor Controller



Roboteq's VSX18xx is a high current, dual channel motor controller composed of a unidirectional half-bridge capable of up to 500A and a 25A bidirectional power bridge. In a typical robotic vehicle configuration, the high current output is connected to the drive motor, while the smaller bridge is connected to the steering motor. The controller can also be used to drive separate excitation motors, with the high current output driving the motor's armature and the small bridge to the motor's excitation (field).

The controller accepts commands received from a RC radio, Analog Joystick, wireless modem, or microcomputer to coordinate the armature and field bridge power so that the motor will move in a precisely controlled manner in the forward or reversed direction.

The motor may be operated in open or closed loop speed mode. Using low-cost position sensors, it may also be set to operate as a heavy-duty position servos. The controller's operation can be extensively automated and customized using Basic Language scripts.

The controller can be configured, monitored and tuned in real-time using a Roboteq's free PC utility. The controller can also be reprogrammed in the field with the latest features by downloading new operating software from Roboteq.

### Applications

- Electric Vehicles
- Automatic Guided Vehicles
- Electric boats
- Industrial Controls
- Hydraulic Pumps control

### Key Features

- RS232, 0-5V Analog, or Pulse (RC radio) command modes
- Auto switch between RS232, Analog, or Pulse based on user-defined priority
- Built-in programming language for automation and customization
- Primary channel with half-bridge (unidirectional) up to 500A
- Secondary channel with full bridge (bidirectional) up to 25A
- Full forward/reverse control of Sepex motors. Four quadrant operation. Supports regeneration
- User programmable curve of Excitation power vs. Armature power
- Compatible with Serial motors. Unidirectional control only
- Operates from a single power source
- Programmable current limit up to 500A for protecting controller, motor, wiring and battery.
- Up to 4 Analog Inputs for use as command and/or feedback
- Up to 5 Pulse Length, Duty Cycle or Frequency Inputs for use as command and/or feedback
- Up to 6 Digital Inputs for use as Deadman Switch, Limit Switch, Emergency stop or as user inputs
- Two general purpose 24V, 1.5A output for brake release or accessories
- Custom scripting in Basic language. Execution speed 50,000+ lines per second
- Selectable min, max, center and deadband in Pulse and Analog modes
- Selectable exponentiation factors on command input
- Trigger action at user programmable Analog or Pulse input levels (soft limit switches)
- Open loop or closed loop speed control operation

- Closed loop position control with analog or pulse/frequency feedback
- PID control loop
- Configurable Data Logging of operating parameters on RS232 Output for telemetry or analysis
- Built-in Battery Voltage and Temperature sensors
- Optional 12V backup power input for powering safely the controller if the main motor batteries are discharged
- Power Control wire for turning On or Off the controller from external microcomputer or switch
- No consumption by output stage when motors stopped
- Regulated 5V output for powering RC radio, RF Modem or microcomputer
- Separate Programmable acceleration and deceleration rate
- Separate Programmable maximum forward and reverse power
- Ultra-efficient 0.4 mOhm ON resistance MOSFETs
- Orderable as dual channel with one unidirectional 500 output and one bidirectional 25A output
- Stall detection and selectable triggered action if Amps is outside user-selected range
- Short circuit protection with selectable sensitivity levels
- Overvoltage and Undervoltage protection
- Watchdog for automatic motor shutdown in case of command loss
- Overtemperature protection
- Diagnostic LED
- Extruded aluminum, heat sinking enclosure for operation harsh shock and temperature environment
- Efficient heat sinking. Operates without a fan in most applications.
- Dustproof and weather resistant. IP51 NEMA rating
- Power wiring via heavy-duty copper bars
- 9" (228.5mm) L, 5.5" W (140mm), 1.6" (40mm) H
- -40o to +85o C operating environment
- 3 lbs (1,350g)
- Easy configuration, tuning and monitory using provided PC utility
- Field upgradeable software for installing latest features via the internet

## Orderable Product References

Reference	Number of Channels	Amps/Channel	Volts
VSX1850	2	500A Ch1, 25A Ch2	50

## Important Safety Disclaimer

**Dangerous uncontrolled motor runaway condition can occur for a number of reasons, including, but not limited to: command or feedback wiring failure, configuration error, faulty firmware, errors in user script or user program, or controller hardware failure.**

**The user must assume that such failures can occur and must make his/her system safe in all conditions. Roboteq will not be liable in case of damage or injury as a result of product misuse or failure.**

## Power Wires Identifications and Connection

Power connections are made by means of copper bars located at the back of the controller for the high-current output to the motor armature.

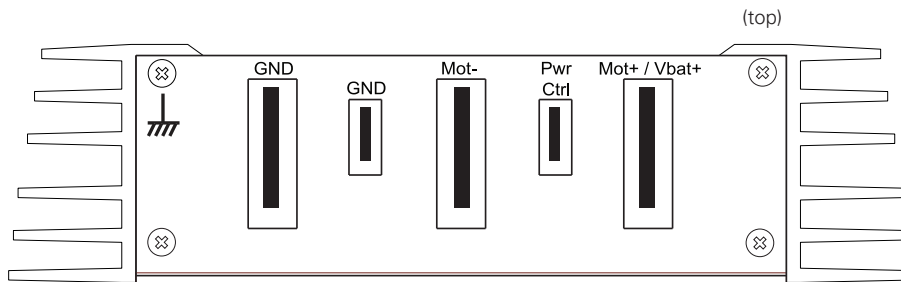

FIGURE 8. Rear Controller Layout

The connection to motor field is done using Fast-On tabs located on the controller's front.

## Important Warning

**Because of the extremely high current on the copper bars, it is imperative that the connection between the wires and the copper bars be perfect. A poor connection will cause potentially damaging heat to be generated at the point of contact between the wire lug and the copper bar.**

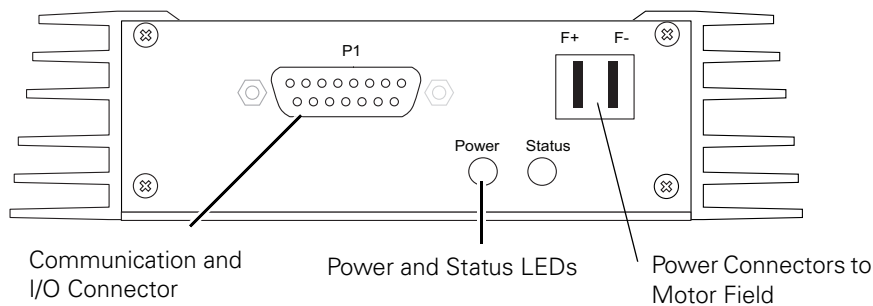

FIGURE 9. Front Controller Layout

The diagram below shows how to wire the controller and how to turn power On and Off.

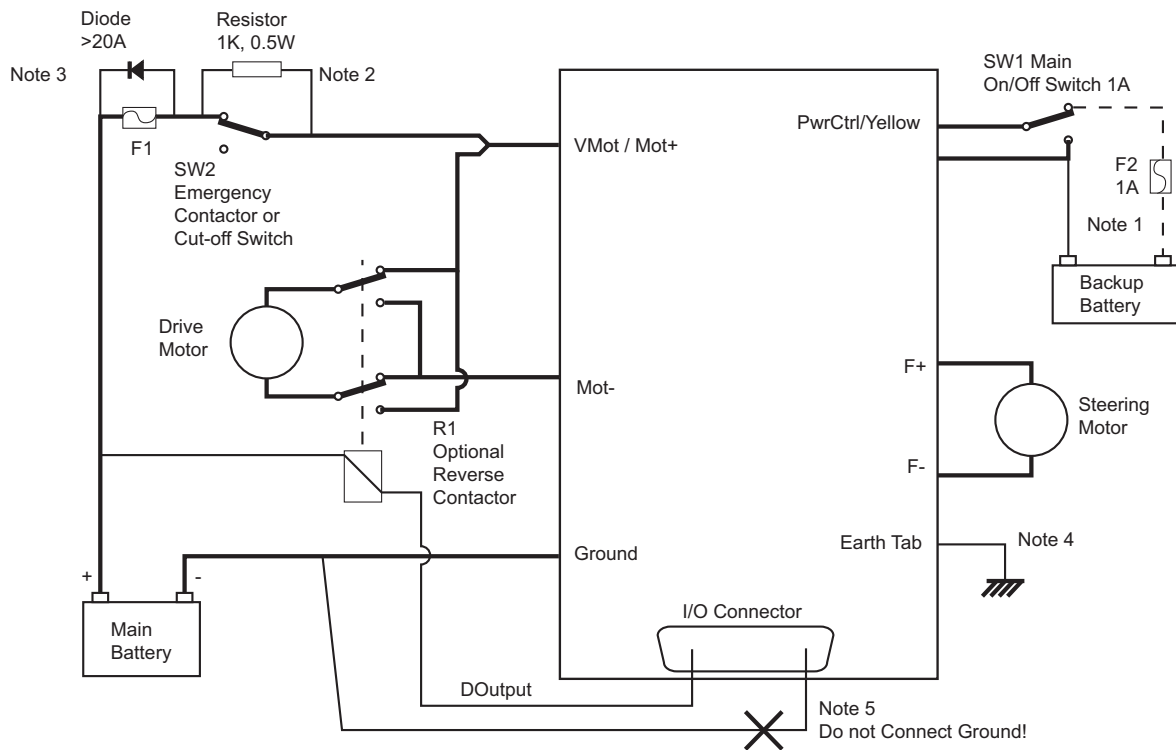

FIGURE 10. Wiring diagram for dual motor configuration. Thick lines identify **MANDATORY** connections

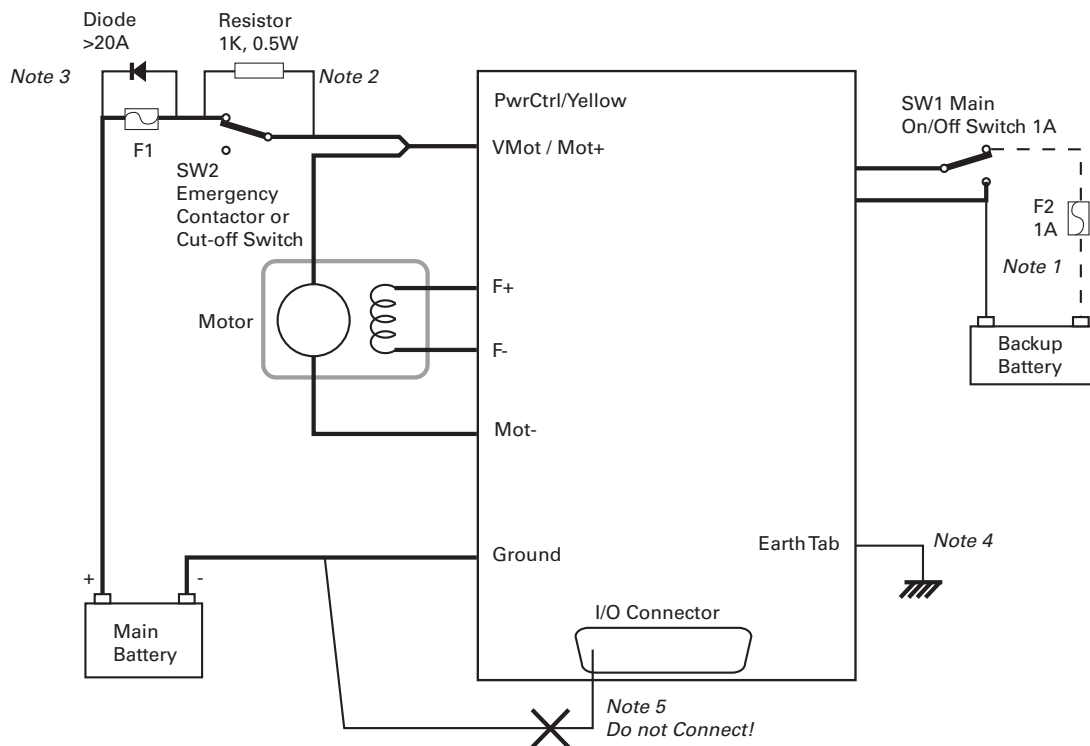

FIGURE 11. Wiring diagram for Sepex motor. Thick lines identify **MANDATORY** connections

## Important Warning

Carefully follow the wiring instructions provided in the Power Connection section of the User Manual. The information on this datasheet is only a summary.

## Mandatory Connections

It is imperative that the controller is connected as shown in the above diagram in order to ensure a safe and trouble-free operation. All connections shown as thick black lines are mandatory. The controller must be powered On/Off using switch SW1 on the Power Control tab. Use a suitable high-current fuse F1 as a safety measure to prevent damage to the wiring in case of major controller malfunction.

## Emergency Switch or Contactor

The battery must be connected in permanence to the controller's VMot and Ground copper bars via a high-power emergency switch or contactor SW2 as additional safety measure. The user must be able to deactivate the switch or contactor at any time, independently of the controller state.

## Precautions and Optional Connections

Note 1: To ensure motor operation with weak or discharged batteries, connect a second battery to the Power Control tab via the SW1 switch.

Note 2: Use precharge 1K, 0.5W Resistor to prevent switch arcing.

Note 3: Insert a high-current diode to ensure a return path to the battery during regeneration in case the fuse is blown.

Note 4: Connect the controller's earth tab to a wire connected to the Earth while the charger is plugged in the AC main, or if the controller is powered by an AC power supply.

Note 5: Beware not to create a path from the ground pins on the I/O connector and the battery minus terminal.

## Use of Safety Contactor for Critical Applications

An external safety contactor must be used in any application where damage to property or injury to person can occur because of uncontrolled motor operation resulting from failure in the controller's power output stage.

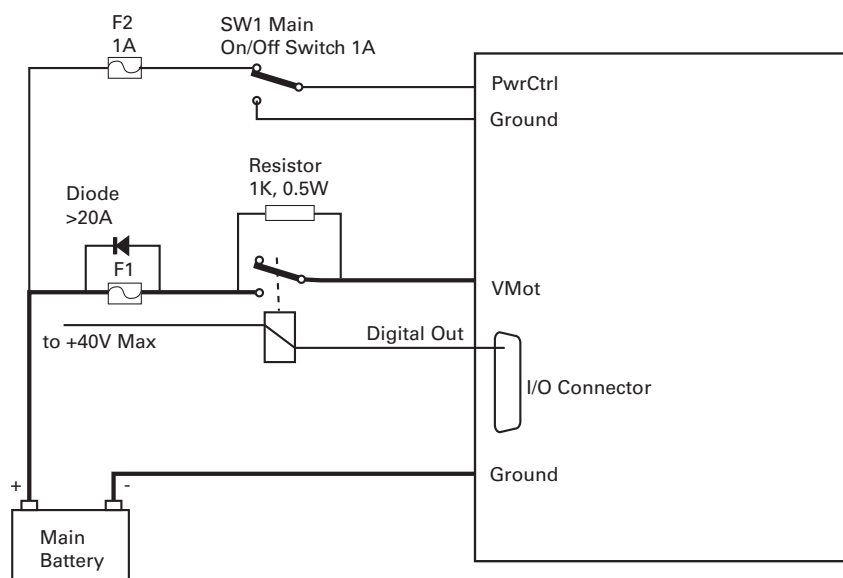

FIGURE 12. Contactor wiring diagram

The contactor coil must be connected to a digital output configured to activate when “No MOSFET Failure.” The controller will automatically deactivate the coil if the output is expected to be off and battery current of 2.5A or more is measured for more than 0.5s. This circuit will not protect against other sources of failure such as those described in the “Important Safety Disclaimer” on page 3.

## Controller Mounting

During motor operation, the controller will generate heat that must be evacuated. The published amps rating can only be fully achieved if adequate cooling is provided. Always operate the controller in a well ventilated space so that air can flow between the heatsink fins. Additional conduction cooling can be achieved by having the bottom edges of the case making contact with a metallic surface (chassis, cabinet).

## Commands and I/O Connection

Connection to RC Radio, Microcomputer, Joystick and other low current sensors and actuators is done via the 15-pin connector located in front of the controller. The functions of some pins vary depending on controller model and user configuration. Pin assignment is found in the table below.

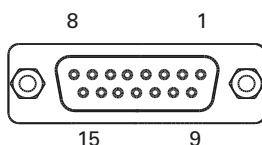

FIGURE 13. Connector pin locations

TABLE 4.

Connector Pin	Power	Dout	Com	RC	Ana	Dinput	Default Config
1		DOUT1					Brake release
9		DOUT2					Safety Contactor
2			TxOut				RS232Tx
10				RC5	ANA1	DIN5	AnaCmd1 (1)
3			RxIn				RS232Rx
11				RC4	ANA4	DIN4	Unused
4				RC1		DIN1	RCRadio1
12				RC3	ANA3	DIN3	Unused
5	GND						
13	GND						
6			SCLI				Reserved
14	5VOut						
7			SDAI				Reserved
15						DIN6	Unused
8				RC2	ANA2	DIN2	Unused

Note 1: Analog command is disabled in factory default configuration.

**Default I/O Configuration**

The controller can be configured so that practically any Digital, Analog and Pulse pin can be used for any purpose. The controller’s factory default configuration provides an assignment that is suitable for most applications. The figure below shows how to wire the controller to an analog potentiometers, an RC radio, and the RS232 port. It also shows how to connect the one of the Digital outputs to a motor brake solenoid. You may omit any connection that is not required in your application. The controller automatically arbitrates the command priorities depending on the presence of a valid command signal in the following order: 1-RS232, 2-RC Pulse, 3-None. If needed, use the Roborun+ PC Utility to change the pin assignments and the command priority order.

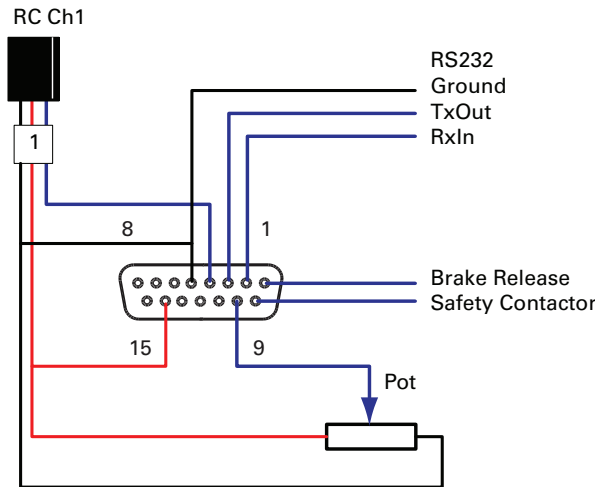

FIGURE 14. Factory default pins assignment

**Enabling Analog Commands**

For safety reasons, the Analog command mode is disabled by default. To enable the Analog mode, use the PC utility and set Analog in Command Priority 2 or 3 (leave Serial as priority 1). Note that by default the additional securities are enabled and will prevent the motor from starting unless the potentiometer is centered, or if the voltage is below 0.25V or above 4.75V. The drawing shows suggested assignment of Pot 1 to ANA1. Use the PC utility to enable and assign analog inputs.

**Status LED Flashing Patterns**

After the controller is powered on, the Power LED will tun on, indicating that the controller is On. The Status LED will be flashing at a 2 seconds interval. The flashing pattern provides operating or exception status information.



FIGURE 15. Normal Operation Flashing Patterns

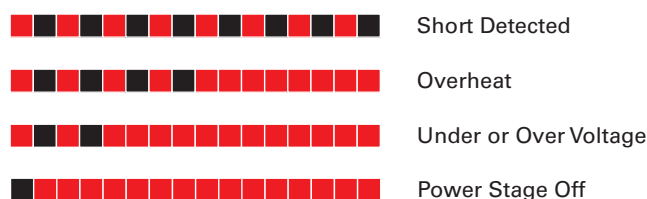

FIGURE 16. Exception or Fault Flashing Patterns

Additional status information may be obtained by monitoring the controller with the PC utility.

## Electrical Specifications

### Absolute Maximum Values

The values in the table below should never be exceeded, Permanent damage to the controller may result.

TABLE 5.

Parameter	Measure point	Min	Typ	Max	Units
Battery Leads Voltage	Ground to VMot			50	Volts
Reverse Voltage on Battery Leads	Ground to VMot	-1			Volts
Power Control Voltage	Ground to Pwr Control wire			65	Volts
Motor Leads Voltage	Ground to Mot-			50 (1)	Volts
Digital Output Voltage	Ground to DOut1/2			40	Volts
Analog and Digital Inputs Voltage	Ground to any signal pin on DSub15 connectors			15	Volts
RS232 I/O pins Voltage	External voltage applied to Rx/Tx pins			15	Volts
Case Temperature	Case	-40		85	oC
Humidity	Case			100 (2)	%

Note 1: Maximum regeneration voltage in normal operation. Never inject a DC voltage from a battery or other fixed source  
 Note 2: Non-condensing

### Power Stage Electrical Specifications (at 25oC ambient)

TABLE 6.

Parameter	Measure point	Min	Typ	Max	Units
Battery Input Voltage	Ground to VMot	0 (1)		50	Volts
Motor Output Voltage	Ground to Mot-, F+ or F-	0 (1)		50 (2)	Volts
Power Control Voltage	Ground to Power Control wire	0 (1)		65	Volts
Minimum Operating Voltage	VMot or Pwr Ctrl wires	9 (3)			Volts
Over Voltage protection range	Ground to VMot	5	50 (4)	50	Volts
Under Voltage protection range	Ground to VMot	0	5 (4)	50	Volts
Idle Current Consumption	VMot or Pwr Ctrl wires	50	100(5)	150	mA
Armature with Main Bridge ON Resistance	Mot- to Ground at 100% power		0.4		mOhm



TABLE 6.

Parameter	Measure point	Min	Typ	Max	Units
Field with Secondary Bridge	F+ to F- at 100% power		6		mOhm
Max Current per channel for 60s	Mot- to Mot+ (Armature)			500	Amps
	F+ to F- (Field)			25	Amps
Continuous Max Current per channel	Mot- to Mot+ (Armature)			250 (6)(7)	Amps
	F+ to F- (Field)			20 (6)	Amps
Current Limit range	Motor current	50	350 (8)	500	Amps
Stall Detection Amps range	Motor current	50	350 (8)	500	Amps
Stall Detection timeout range	Motor current	1	65000 (9)	65000	milli-seconds
Short Circuit Detection threshold (10)	Between Mot- and Ground	5000		10000 (11)	Amps
	Between F+ and F-. Between F+ or F- and Ground	280		800 (11)	Amps
Short Circuit Detection threshold	Between Mot-, F+ or F-, and VMot	No Protection. Permanent damage will result			
Motor Acceleration/Deceleration range	Motor output	100	500 (12)	65000	milli-seconds

Note 1: Negative voltage will cause a large surge current. Protection fuse needed if battery polarity inversion is possible

Note 2: Maximum regeneration voltage in normal operation. Never inject a DC voltage from a battery or other fixed source

Note 3: Minimum voltage must be present on VMot or Power Control wire

Note 4: Factory default value. Adjustable in 0.1V increments

Note 5: Current consumption is lower when higher voltage is applied to the controller's VMot or PwrCtrl wires

Note 6: Max value is determined by current limit setting. Duration is estimated and is dependent on ambient temperature cooling condition

Note 7: Estimate. Limited by case temperature. Current may be higher with better cooling

Note 8: Factory default value. Adjustable

Note 9: Factory default value. Time in ms that Stall current must be exceeded for detection

Note 10: Controller will stop until restarted in case of short circuit detection

Note 11: Sensitivity selectable by software

Note 12: Factory default value. Time in ms for power to go from 0 to 100%

## Command, I/O and Sensor Signals Specifications

TABLE 7.

Parameter	Measure point	Min	Typ	Max	Units
Main 5V Output Voltage	Ground to 5V pins on	4.6	4.75	4.9	Volts
5V Output Current	5V pins on RJ45 and DSub15			200 (1)	mA
Digital Output Voltage	Ground to Output pins			40	Volts
Output On resistance	Output pin to ground		0.25	0.5	Ohm
Output Short circuit threshold	Output pin	1.7		3.5	Amps
Digital Output Current	Output pins, sink current			1.5	Amps
Input Impedances (except DIN11-19)	AIN/DIN Input to Ground		53		kOhm
Digital Input 0 Level	Ground to Input pins	-1		1	Volts

TABLE 7.

Parameter	Measure point	Min	Typ	Max	Units
Digital Input 1 Level	Ground to Input pins	3		15	Volts
Analog Input Range	Ground to Input pins	0		5.1	Volts
Analog Input Precision	Ground to Input pins		0.5		%
Analog Input Resolution	Ground to Input pins		1		mV
Pulse durations	Pulse inputs	20000		10	us
Pulse repeat rate	Pulse inputs	50		250	Hz
Pulse Capture Resolution	Pulse inputs		1		us
Frequency Capture	Pulse inputs	100		10000	Hz

Note 1: Sum of all 5VOut outputs

## Operating & Timing Specifications

TABLE 8.

Parameter	Measure Point	Min	Typ	Max	Units
Command Latency	Command to output change	1	0.5	1	ms
PWM Frequency	Ch1, Ch2 outputs	10	18 (1)	20	kHz
Closed Loop update rate	Internal		1000		Hz
RS232 baud rate	Rx & Tx pins		115200 (2)		Bits/s
RS232 Watchdog timeout	Rx pin	1 (3)		65000	ms

Note 1: May be adjusted with configuration program

Note 2: 115200, 8-bit, no parity, 1 stop bit, no flow control

Note 3: May be disabled with value 0

## Scripting

TABLE 9.

Parameter	Measure Point	Min	Typ	Max	Units
Scripting Flash Memory	Internal		8192		Bytes
Max Basic Language programs	Internal	1000		1500	Lines
Integer Variables	Internal		1024		Words (1)
Boolean Variables	Internal		1024		Symbols
Execution Speed	Internal	50 000	100 000		Lines/s

Note 1: 32-bit words

## Thermal Specifications

TABLE 10.

Parameter	Measure Point	Min	Typ	Max	Units
Case Temperature	Case	-40		85 (1)	oC
Thermal Protection range	Case	80		90 (2)	oC
Power Dissipation	Case			70	Watts

TABLE 10.

Parameter	Measure Point	Min	Typ	Max	Units
Thermal resistance	Power MOSFETs to case			0.6	oC/W
Note 1: Thermal protection will protect the controller power					
Note 2: Max allowed power out starts lowering at minimum of range, down to 0 at max of range					

**Mechanical Specifications**

TABLE 11.

Parameter	Measure Point	Min	Typ	Max	Units
Weight	Case		1.0 (2.0)		kg (lbs)

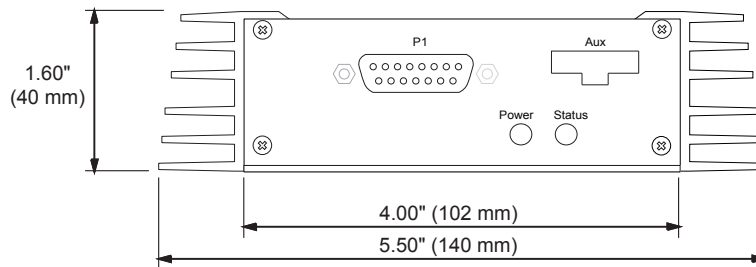

FIGURE 17. VSX18xx front view and dimensions

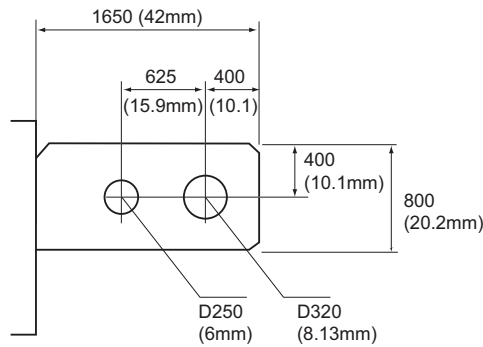

FIGURE 18. High Current copper bar connectors

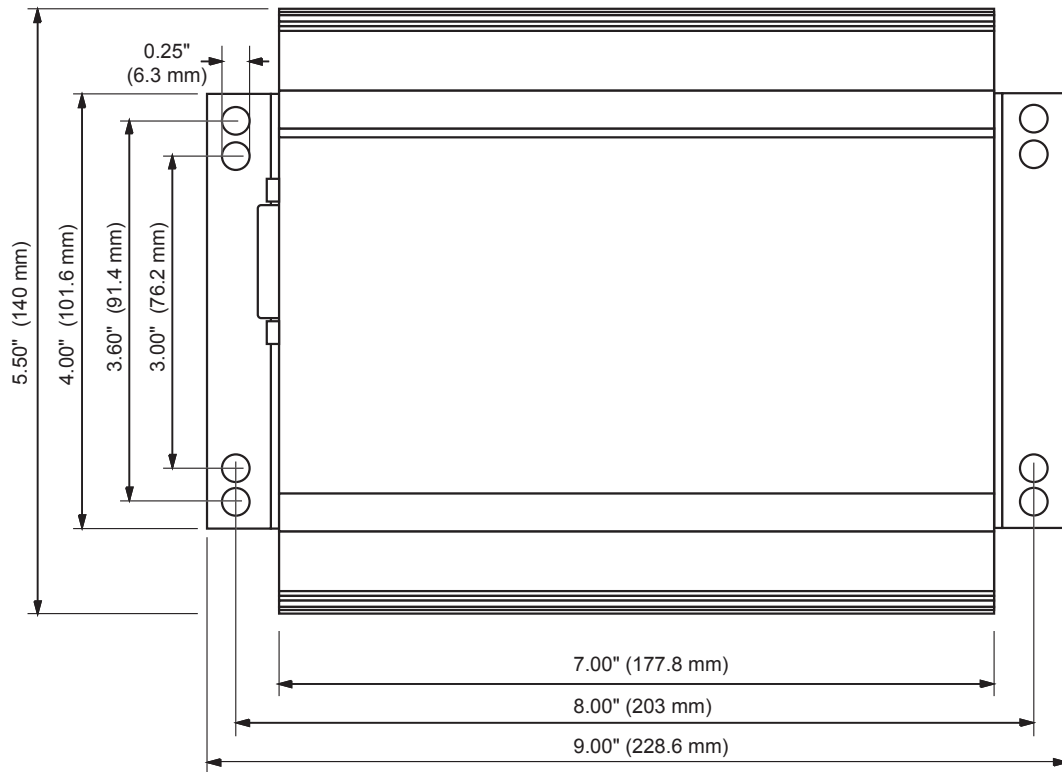

FIGURE 19. VSX18xx top view and dimensions