

Skywire™ LTE CAT4 HL7588 Embedded Cellular Modem Datasheet

NimbeLink Corp

Updated: October 2016



© NimbeLink Corp. 2016. All rights reserved.

NimbeLink Corp. provides this documentation in support of its products for the internal use of its current and prospective customers. The publication of this document does not create any other right or license in any party to use any content contained in or referred to in this document and any modification or redistribution of this document is not permitted.

While efforts are made to ensure accuracy, typographical and other errors may exist in this document. NimbeLink reserves the right to modify or discontinue its products and to modify this and any other product documentation at any time.

All NimbeLink products are sold subject to its published Terms and Conditions, subject to any separate terms agreed with its customers. No warranty of any type is extended by publication of this documentation, including, but not limited to, implied warranties of merchantability, fitness for a particular purpose and non-infringement.

XBee is a registered trademark of Digi International, Inc

NimbeLink is a registered trademark, and Skywire is a trademark, of NimbeLink Corp. All trademarks, service marks and similar designations referenced in this document are the property of their respective owners.

Table of Contents

[Table of Contents](#)

[Introduction](#)

[Orderable Part Numbers](#)

[Additional Resources](#)

[Product Overview](#)

[Block Diagram](#)

[Technical Specifications](#)

[Electrical Specifications](#)

[Absolute Maximum Ratings](#)

[Recommended Ratings & Module Pin out](#)

[Connectors J1 and J2](#)

[Connectors J3, X1, X2](#)

[Mechanical Specifications](#)

[Mechanical Characteristics](#)

[Mating Connectors](#)

[Device Placement](#)

[Environmental Specifications](#)

[Important Design Considerations](#)

[PWR_ON Signal](#)

[Power Supply Requirements](#)

[Serial Communications](#)

[Mounting Guidelines](#)

[Board to Board connectors approach](#)

[Solder to Board connection approach](#)

[Antenna Considerations](#)

[Primary Antenna Requirement](#)

[Diversity Antenna Requirements](#)

[Recommended Antennas](#)

[Certifications](#)

[Carrier Specific](#)

[Geography Specific](#)

[Federal Regulatory Licensing](#)

[End Product Labeling Requirements](#)

1. Introduction

1.1 Orderable Part Numbers

Orderable Device	Firmware Revision	Operating Temperature	Bands	Fallback?	Network Type
NL-SW-LTE-S7588-V	V.3.6	-40 to +85°C	B2,B4, B5,B13,B17	UMTS B2, B5*	Verizon
NL-SW-LTE-S7588-T	A.2.10	-40 to +85°C	B2,B4, B5,B13,B17	UMTS B2, B5	AT&T/T-mobile

**May require World Wide SIM from Verizon*

1.2 Additional Resources

The following documents or documentation resources are referenced within this document.

- [Sending SMS](#)
- [Configuring linux 'pppd'](#)
- [Sending and Receiving data using socket dial](#)
- [Sierra's HL7588 Product Technical Resources](#)
- [Sierra's HL7588 AT Command Manual](#)
- [Sierra's HL7588 Verizon Firmware Update](#)
- [Sierra's HL7588 AT&T Firmware Update](#)

1.3 Product Overview

Add robust cellular connectivity to your M2M devices with scalable radio technology with Skywire line of modems including HL7588 based LTE solutions. Extensive experience in designing and building embedded product solutions makes the NimbeLink Skywire™ embedded cellular modem the smallest on the market. It complies with the popular XBEE® interface standard and supports multiple LTE bands and fallback capability minimizing costs of hardware and network access. The module is designed for volume production and is intended for OEMs to embed into end equipment designs.

1.4 Block Diagram

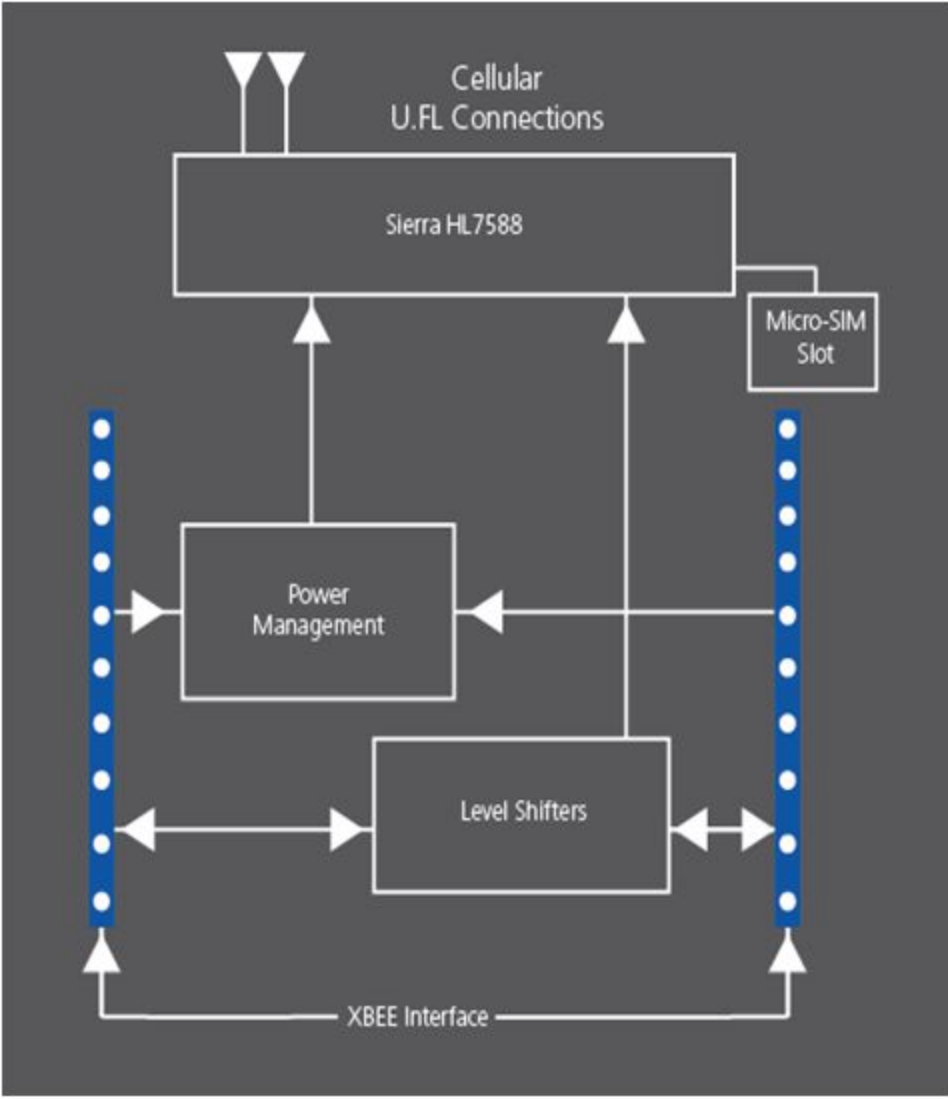

2. Technical Specifications

2.1 Electrical Specifications

2.1.1 Absolute Maximum Ratings

Parameter	Signal	Maximum Rating
Main Power Supply	VCC	5.5V
I/O Voltage Reference	VREF	5.5V

2.1.2 Recommended Ratings & Module Pin out

2.1.2.1 Connectors J1 and J2

Pin	Name	Direction	Description	Min	Typical	Max	If not used
1	VCC	Input	Main Power supply	3.0V	3.9V	5.5V	Must be implemented
2	DOUT	Output	UART data out, I/O level tied to VREF	VOL: GND to 0.55V		VOH: VREF x 0.67 to VREF	Must be implemented if USB not used, No connection
3	DIN	Input	UART data in, I/O level tied to VREF	VIL: GND to 0.15V		VIH: VREF-0.4V to VREF	Must be implemented if USB not used, No connection
4	GND	Input	Ground Pin		0		Must be implemented
5	RESET_nIN	Input	Controls RESET input on Sierra HL7588, tie low for a minimum of 20ms and released to activate. Internally pulled up to VCC. Drive with open collector output. Assert only in an emergency as the module will not gracefully exit the cellular network when asserted.		VREF		No connection
6	VUSB	Input	Supply for USB interface	5V	5V	5V	No connection
7	USB_D+	I/O	USB differential Data + signal				No connection
8	USB_D-	I/O	USB differential Data - signal				No connection
9	DTR	Input	Modem Data Terminal Ready input	VIL: GND to 0.15V		VIH: VREF-0.4V to VREF	Tie to GND
10	GND	Input	Ground Pin		0		Must be implemented
11	GND	Input	Ground Pin		0		Must be implemented
12	CTS	Output	Modem Clear to Send hardware flow control output	VOL: GND to 0.55V		VOH: VREF x 0.67 to VREF	No connection

13	VGPIO	Output	Signal drives high indicating the modem is on and ready for commands. (It can be idle, or in sleep mode)May also be used to power external level shifters to interface to DIO5 or DIO7. See HL7588 manual for additional information.	0		1.8V	No connection
14	VREF	Input	Voltage reference for off board I/O signals. This signal drives the input voltage side of an onboard buffer which converts all external I/O voltage from VREF range to 1.8V range to drive the onboard HL7588 modem module.	1.65V	1.8V or 3.3V	5.5V	Must be implemented
15	GND	Input	Ground Pin		0		Must be implemented
16	RTS	Input	Modem Request to Send hardware flow control input	VIL: GND to 0.15V		VIH: VREF-0.4V to VREF	Tie to GND
17	DIO5	I/O	Programmable GPIO_05 on HL7588 module	0		1.8V	No connection
18	DIO7	I/O	Programmable GPIO_07 on HL7588 module	0		1.8V	No connection
19	ADC1	Input	ADC_IN1 input on HL7588 module (10bit resolution)	0		1.2V	No connection
20	PWR_ON	Input	Modem PWR_ON signal. Assert low for at least 25 msec and then release to activate start sequence. Drive with open collector output. Internally pulled up to internal I/O rail with resistor. Do not use any external pull ups. Note: If you want modem to turn on automatically when power is applied, permanently tie this signal to GND. Must execute AT+CPOF to power down the modem.	0		1.8V	Must be implemented.

2.1.2.2 Connectors J3, X1, X2

Connector Designator	Description	Connector Location
J3	Micro SIM Connector	Bottom Side of Module
X1	Primary Antenna Connection	Topside of Module
X2	Diversity Antenna Connection	Topside of Module

2.2 Mechanical Specifications

2.2.1 Mechanical Characteristics

Parameter	Typical	Unit
Dimensions (excluding pin height, for solder to board applications)	29.0 x 33.60 x 6.63	mm
Dimensions (including pin height, for board to board connector applications)	29.0 x 33.60 x 10.73	mm
Weight	0.4	oz
Connector Insertion/Removal	hundreds	Cycles

2.2.2 Mating Connectors

Connector Designator	Manufacturer	Populated on Module	Recommended Mate	Mate Manufacturer
J1, J2	3M	Pinrex 222-96-10GBE1	NPPN101BFCN-RC	Sullins Connector Solutions
			Acceptable Alternative: 950510-6102-AR	3M
J3	Molex	786463001	NL-SIM-COM	Nimbelink
X1, X2	Hirose	U.FL-R-SMT(10)	CAB.011	Taoglas

2.2.3 Device Placement

⚠ Make sure the Skywire™ is installed in the correct orientation; failure to do so will damage the device and void the warranty.

2.3 Environmental Specifications

Parameter	Min	Typical	Max	Unit	Notes
Operating Temperature	-40	25	+85	°C	
Storage Temperature	-40	25	+85	°C	
Operating Humidity	20		90	%	Non-condensing

3. Important Design Considerations

3.1 PWR_ON Signal

To conserve power, the HL7588 does not automatically startup when power is applied. The baseboard design must supply a means to assert the PWR_ON signal for the specified time (at least 25 msec) and then released to startup the module. After asserting the PWR_ON signal, software must wait for VGPIO to assert before attempting to communicate with the HL7588. To make module automatically start when power is applied, tie PWR_ON signal to GND permanently. See Sierra Hardware User Guide for additional details regarding the PWR_ON signal.

3.2 Power Supply Requirements

The module will regularly consume high amounts of current on the Main Power Supply (VCC), up to 1.5A during active transmits and receives. The baseboard power supply should be designed to support peak currents up to 2 Amps. A 100uF capacitor should be placed near the VCC pin on the module to ensure ample energy is available, with a low inductance path to the VCC pin. For example power supply designs, there are multiple references available. See the NimbeLink Skywire™ Development Kit schematic for a switching regulator example.

3.3 Serial Communications

The HL7588 can communicate over UART and/or USB. Design should implement one or both serial interfaces to be able to send commands to the modem.

3.4 LED

The Skywire has an on board LED D1 connected to HL7588 on GPIO10. This LED can be asserted by software by issuing an AT command.

```
AT+KGPIO=10,1 //Turn on LED
```

```
AT+KGPIO=10,0 //Turn off LED
```

4. Mounting Guidelines

The Skywire™ embedded cellular modem supports multiple connection methods, the two primary methods are board to board connectors and soldering directly to the baseboard.

4.1 Board to Board connectors approach

The XBEE® form factor calls for two, 10 pin, 2mm pitch female receptacles.

There are many connector manufacturers that can be used; below is one readily available product:

Manufacture: Sullins Connector Solution

Alternate: 3M

Part Number: NPPN101BFCN-RC

Alternate P/N: 950510-6102-AR

Typical part drawing and footprint information:

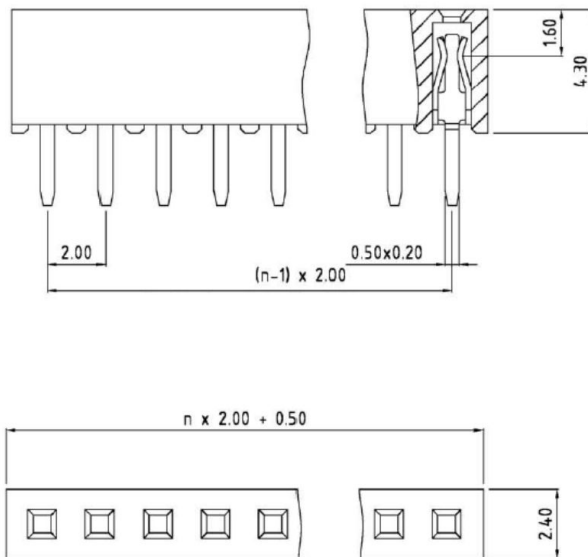

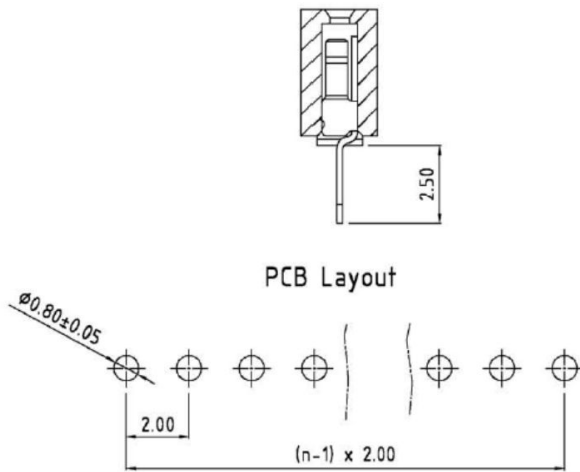

4.2 Solder to Board connection approach

The module can be soldered directly to a PCB. The PCB should be designed with two rows of ten, 0.8mm plated thru holes spaced 2mm apart. The two rows should be 22mm apart. See drawing for recommended footprint. Measurements are in millimeters. U.FL locations are marked with circles, X1 and X2 on top side of board, J3 is Micro SIM card slot on bottom side of board.

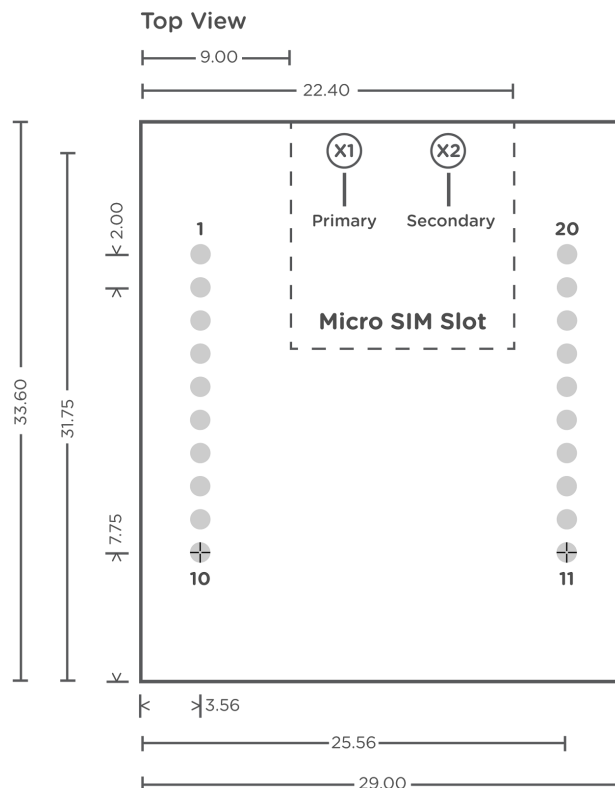

5. Antenna Considerations

5.1 Primary Antenna Requirement

Designers should review latest HL7588 Hardware User Guide to ensure the information is up to date.

PRIMARY ANTENNA REQUIREMENTS	
Frequency Range	Depending on the frequency bands provided by the network operator, the customer shall use the most suitable antenna for those bands
Bandwidth	LTE B2(1900): 140MHz UMTS B2(1900): 140MHz LTE B4(1700): 445MHz UMTS B5(850): 70MHz LTE B5(850): 70MHz LTE B13(700c): 41MHz LTE B17(700b): 42MHz
Impedance	50 ohm
Input Power	TBD
VSWR Max	4:1

5.2 Diversity Antenna Requirements

Designers should review latest HL7588 Hardware User Guide to ensure the information is up to date.

RX DIVERSITY ANTENNA REQUIREMENTS	
Frequency Range	Depending on the frequency bands provided by the network operator, the customer shall use the most suitable antenna for those bands
Bandwidth	LTE B2(1900): 60MHz UMTS B2(1900): 60MHz LTE B4(1700): 45MHz UMTS B5(850): 25MHz LTE B5(850): 25MHz LTE B13(700c): 10MHz LTE B17(700b): 12MHz
Impedance	50 ohm
VSWR Recommended	< 2:1 for best sensitivity

5.3 Recommended Antennas

Type	Manufacturer	Part Number
Primary & Diversity	Taoglas ¹	TG.30.8113

Note 1: U.FL to SMA adapter required.

For applications not using the recommended antennas developers will need to ensure that the selected antenna(s) must meet the following gain requirements:

Frequency Band (MHz)	Max Gain (dBi)
800/850	9.72
900	9.74
1700	5.78
1900	7.51

6. Certifications

6.1 Carrier Specific

NL-SW-LTE-S7588-V	Verizon OD Certified
NL-SW-LTE-S7588-T	PTCRB Certified
NL-SW-LTE-S7588-T	AT&T Certified

6.2 Geography Specific

Federal Communications Commission (FCC47) part 22, 24
Complies with FCC47 Part 15 Class B Radiated and Conducted Emissions

7. Federal Regulatory Licensing

7.1 Export Control Classification Number (ECCN)

ECCNs are five character alpha-numeric designations used on the Commerce Control List (CCL) to identify dual-use items for export control purposes. An ECCN categorizes items based on the nature of the product, i.e. type of commodity, software, or technology and its respective technical parameters.

All Skywire Modems: 5A992.a

7.2 Harmonized Tariff Schedule Code

HTS Code: 8517.62.0010

8. End Product Labeling Requirements

Device Uses Approved Radio: NL-SW-LTE-S7588

Contains FCC ID: N7NHL7588 and IC ID: 2417C-HL7588

This device complies with Part 15 of the FCC Rules. Operation is subject to the following two conditions: (1) This device may not cause harmful interferences, and (2) this device must accept any interference received, including interference that may cause undesired operation.