

Skywire™ LTE CAT 1 M14A2A Embedded Cellular Modem Datasheet

NimbeLink Corp

Updated: Jan 2017



© NimbeLink Corp. 2017. All rights reserved.

NimbeLink Corp. provides this documentation in support of its products for the internal use of its current and prospective customers. The publication of this document does not create any other right or license in any party to use any content contained in or referred to in this document and any modification or redistribution of this document is not permitted.

While efforts are made to ensure accuracy, typographical and other errors may exist in this document. NimbeLink reserves the right to modify or discontinue its products and to modify this and any other product documentation at any time.

All NimbeLink products are sold subject to its published Terms and Conditions, subject to any separate terms agreed with its customers. No warranty of any type is extended by publication of this documentation, including, but not limited to, implied warranties of merchantability, fitness for a particular purpose and non-infringement.

XBee is a registered trademark of Digi International, Inc

NimbeLink is a registered trademark, and Skywire is a trademark, of NimbeLink Corp. All trademarks, service marks and similar designations referenced in this document are the property of their respective owners.

Table of Contents

Table of Contents	2
Introduction	4
Orderable Part Numbers	4
Additional Resources	4
Product Overview	4
Block Diagram	5
Technical Specifications	6
Electrical Specifications	6
Absolute Maximum Ratings	6
Recommended Ratings & Module Pin out	6
Connectors J1 and J2	6
Connectors J3, X1, X2	7
Mechanical Specifications	8
Mechanical Characteristics	8
Mating Connectors	8
Device Placement	8
Environmental Specifications	8
Important Design Considerations	9
PWR_ON Signal	9
Power Supply Requirements	9
Serial Communications	9
LED	9
GPIO Control	9
WAKE Pins	10
Mounting Guidelines	11
Board to Board connectors approach	11
Solder to Board connection approach	12
Antenna Considerations	13
Supported Frequencies	13
Conducted TX Power	13
Conducted RX Sensitivity	13
Primary Antenna Requirements	14
Diversity Antenna Requirements	14

Recommended Antennas	14
Certifications	15
Carrier Specific	15
Geography Specific	15
Federal Regulatory Licensing	15
End Product Labeling Requirements	15

1. Introduction

1.1 Orderable Part Numbers

Orderable Device	Firmware Revision	Operating Temperature	Bands	Fallback	Network Type
NL-SW-LTE-WM14	v11.50.164451	-25 to +75°C	B2, B4, B12	None	LTE
NL-SIM-ATT	Coming Soon				AT&T
NL-SIM-TMO	Coming Soon				T-Mobile
NL-SIM-VOD	Coming Soon				Vodafone

1.2 Additional Resources

The following documents or documentation resources are referenced within this document.

- WNC's M14A2A Hardware Design Guidelines
- WNC's M14A2A AT Command Manual

1.3 Product Overview

Add robust cellular connectivity to your M2M devices with scalable radio technology with Skywire line of modems including M14A2A-based LTE solutions. Extensive experience in designing and building embedded product solutions makes the NimbeLink Skywire™ embedded cellular modem the smallest on the market. It complies with the popular XBEE® interface standard and supports multiple LTE bands minimizing costs of hardware and network access. The module is designed for volume production and is intended for OEMs to embed into end equipment designs.

1.4 Block Diagram

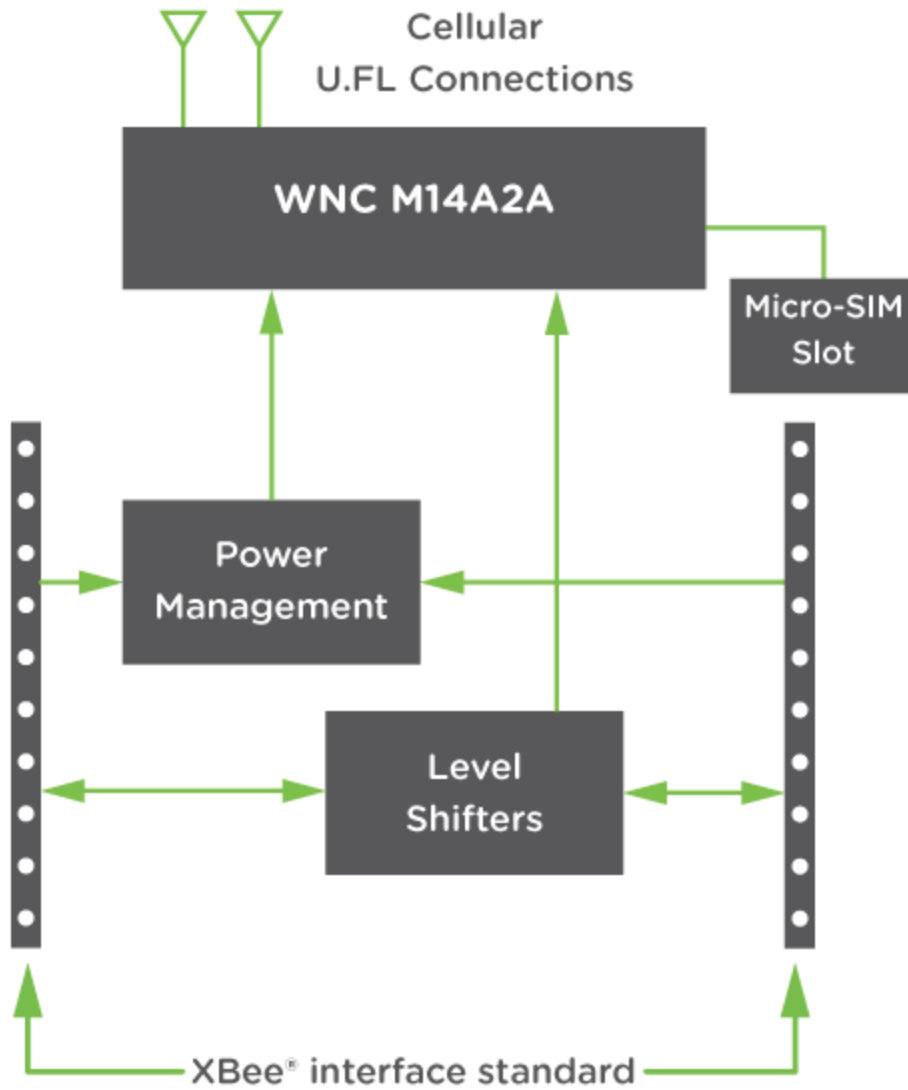

2. Technical Specifications

2.1 Electrical Specifications

2.1.1 Absolute Maximum Ratings

Parameter	Signal	Maximum Rating
Main Power Supply	VCC	5.5V
I/O Voltage Reference	VREF	5.5V

2.1.2 Recommended Ratings & Module Pin out

2.1.2.1 Connectors J1 and J2

Pin	Name	Direction	Description	Min	Typical	Max	If not used
1	VCC	Input	Main Power supply	3.0V	3.9V	5.5V	Must be implemented
2	DOUT	Output	UART data out, I/O level tied to VREF	VOL: GND to 0.55V		VOH: VREF x 0.67 to VREF	Must be implemented if USB not used, No connection
3	DIN	Input	UART data in, I/O level tied to VREF	VIL: GND to 0.15V		VIH: VREF-0.4 V to VREF	Must be implemented if USB not used, No connection
4	GND	Input	Ground Pin		0		Must be implemented
5	RESET_nIN	Input	Controls RESET input on WNC M14A2A, tie low for a minimum of 100msec and released to activate. Internally pulled up to WNC VREF pin. Drive with open collector output. Assert only in an emergency as the module will not gracefully exit the cellular network when asserted.		VREF		No connection
6	VUSB	Input	Supply for USB interface	4.4V	5V	5V	No connection
7	USB_D+	I/O	USB differential Data + signal				No connection
8	USB_D-	I/O	USB differential Data - signal				No connection
9	nWAKE_IN	Input	Controls the M14A2A's WAKEUP_IN input. HIGH means the host does not need the MODEM (allowing it to sleep). LOW means the host needs the Skywire or acknowledges it is ready following a wakeup from the Skywire. See WAKE Pins section for more information.	0		1.8V	No connection
10	GND	Input	Ground Pin		0		Must be implemented
11	GND	Input	Ground Pin		0		Must be implemented

12	CTS	Output	Modem Clear to Send hardware flow control output	VOL: GND to 0.55V		VOH: VREF x 0.67 to VREF	No connection
13	nWAKE_OUT	Output	Controls the M14A2A's WAKEUP_OUT input. HIGH means the Skywire does not need the host (allowing it to sleep). LOW means the Skywire needs the host or acknowledges it is ready following a wakeup from the host. See WAKE Pins section for more information.	0		1.8V	Tie to GND.
14	VREF	Input	Voltage reference for off board I/O signals. This signal drives the input voltage side of an onboard buffer which converts all external I/O voltage from VREF range to 1.8V range to drive the onboard M14A2A modem module.	1.65V	1.8V or 3.3V	5.5V	Must be implemented
15	GND	Input	Ground Pin		0		Must be implemented
16	RTS	Input	Modem Request to Send hardware flow control input	VIL: GND to 0.15V		VIH: VREF-0.4 V to VREF	Tie to GND
17	GPIO2	I/O	Programmable GPIO02 on M14A2A module. See GPIO section for further details	0		1.8V	No connection
18	GPIO3	I/O	Programmable GPIO03 on M14A2A module. See GPIO section for further details	0		1.8V	No connection
19	ADC1	Input	ADC input on M14A2A module (10-bit resolution)	0		1.8V	No connection
20	ON_OFF	Input	Modem POWER_ON signal. Modem is ON when ON_OFF is tied to GND.	0		1.8V	Must be implemented.

2.1.2.2 Connectors J3, X1, X2

Connector Designator	Description	Connector Location
J3	Micro SIM Connector	Bottom Side of Module
X1	Primary Antenna Connection	Topside of Module
X2	Diversity Antenna Connection	Topside of Module

2.2 Mechanical Specifications

2.2.1 Mechanical Characteristics

Parameter	Typical	Unit
Dimensions (excluding pin height, for solder to board applications)	29.0 x 33.60 x 6.63	mm
Dimensions (including pin height, for board to board connector applications)	29.0 x 33.60 x 10.73	mm
Weight	0.4	oz
Connector Insertion/Removal	hundreds	Cycles

2.2.2 Mating Connectors

Connector Designator	Manufacturer	Populated on Module	Recommended Mate	Mate Manufacturer
J1, J2	3M	951110-2530 -AR-PR	950510-6102-AR	3M
			Acceptable alternate: NPPN101BFCN-RC	Sullins Connector Solutions
J3	Molex	786463001	Micro SIM Card	Micro SIM Card
X1, X2	Hirose	U.FL-R-SMT(1 0)	CAB.011	Taoglas

2.2.3 Device Placement

⚠ Make sure the Skywire™ is installed in the correct orientation; failure to do so will damage the device and void the warranty.

2.3 Environmental Specifications

Parameter	Min	Typical	Max	Unit	Note
Operating Temperature	-25	25	+75	°C	
Operating Humidity	20		90	%	Non-condensing

3. Important Design Considerations

3.1 PWR_ON Signal

In order to power on the M14A2A, ON_OFF must be tied to GND. This is different than some Skywire models that only require a pulsed low on the PWR_ON Signal.

3.2 Power Supply Requirements

The module will regularly consume high amounts of current on the Main Power Supply (VCC), up to 1.5A during active transmits and receives. The baseboard power supply should be designed to support peak currents up to 2 Amps. A 100uF capacitor should be placed near the VCC pin on the module to ensure ample energy is available, with a low inductance path to the VCC pin. For example power supply designs, there are multiple references available. See the NimbeLink Skywire™ Development Kit schematic for a switching regulator example.

3.3 Serial Communications

The M14A2A can communicate over UART and/or USB. Design should implement one or both serial interfaces to be able to send commands to the modem.

3.4 LED

The Skywire has an on board LED D1 connected to M14A2A's WWAN_STATE pin. The LED will turn on when the M14A2A is registered on the network, and will turn off indicating no cellular connection.

3.5 GPIO Control

Modem interface Pins 17 and 18 can be used as a GPIO input or output via AT Commands. Please consult the WNC M14A2A AT Command Manual for more examples and command specifics:

Configure M14A2A GPIO02 as GPIO pin:

```
AT@GPIOREQ=1,2  
OK
```

Set GPIO02 as output driving high (1.8V):

```
AT@GPIOCFG=2,1,1  
OK
```

Get GPIO02's state:

```
AT@GPIOGET=2
```

@GPIOGET:1

OK

Drive GPIO02's state low (0V):

AT@GPIOSET=2,0

OK

GET GPIO02's state:

AT@GPIOGET=2

@GPIOGET:0

3.6 WAKE Pins

The M14A2A has the capability to enter low power states, and awakened when needed via the WAKE_IN and WAKE_OUT pins. This allows an external host controller to wake the M14A2A when needed, as well as allows the M14A2A to wake a host controller when needed.

Below is a brief description of the WAKE pin's functions. Please consult the WNC M14A2A Hardware Design Guidelines document for specific information.

Note: Due to the inverters placed on the Skywire NL-SW-LTE-WM14 modem, the functionality listed in the WNC M14A2A Hardware Design Guidelines document is inverted from the below information and from the functionality of the Skywire.

WAKEUP_IN Pin (Host: Output, Modem: Input):

- LOW: Host needs the Skywire or acknowledges it is ready following a wakeup request from the Skywire.
- HIGH: Host does not need the Skywire (allowing it to sleep).

WAKEUP_OUT Pin (Host: Input, Modem: Output):

- LOW: Skywire needs the Host or acknowledges it is ready following a wakeup request from the host.
- HIGH: Skywire does not need the Host (allowing it to sleep).

4. Mounting Guidelines

The Skywire™ embedded cellular modem supports multiple connection methods, the two primary methods are board to board connectors and soldering directly to the baseboard.

4.1 Board to Board connectors approach

The XBEE® form factor calls for two, 10 pin, 2mm pitch female receptacles.

There are many connector manufacturers that can be used; below is one readily available product:

Manufacturer: 3M

Alternate: Sullins Connector Solutions

Part Number: 950510-6102-AR

Alternate P/N: NPPN101BFCN-RC

Typical part drawing and footprint information:

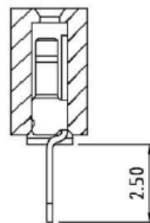
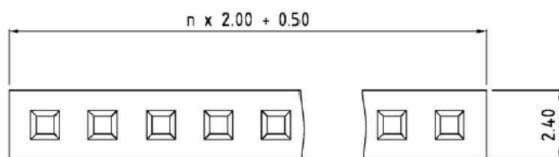
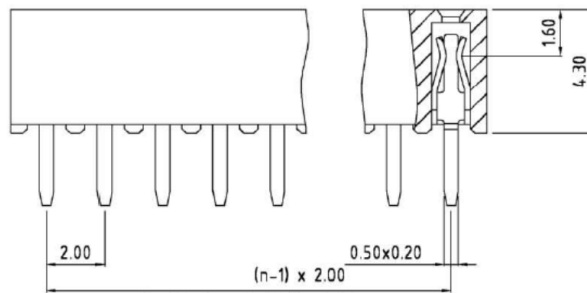

PCB Layout

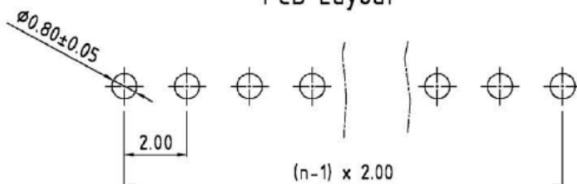

4.2 Solder to Board connection approach

The module can be soldered directly to a PCB. The PCB should be designed with two rows of ten, 0.8mm plated thru holes spaced 2mm apart. The two rows should be 22mm apart. See drawing for recommended footprint. Measurements are in millimeters. U.FL locations are marked with circles, X1 and X2 on top side of board, J3 is Micro SIM card slot on bottom side of board.

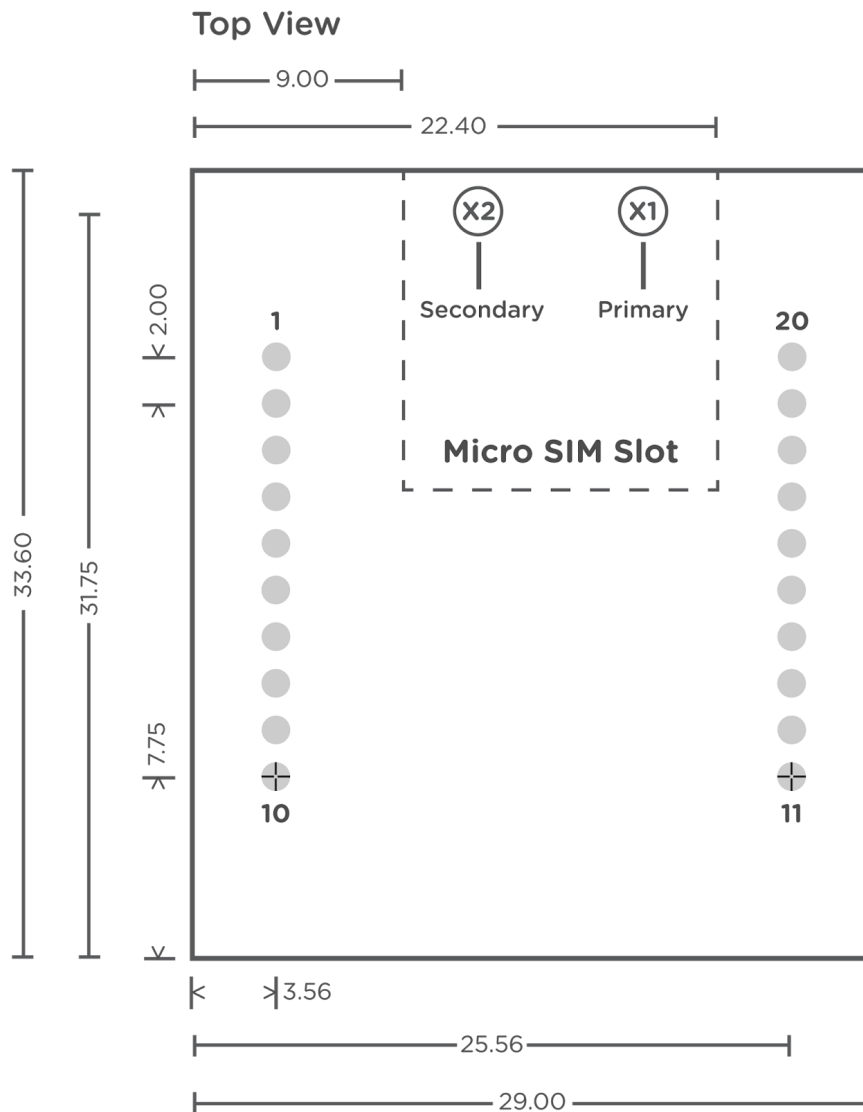

5. Antenna Considerations

5.1 Supported Frequencies

Designers should review latest M14A2A Hardware Design Guidelines to ensure the information is up to date.

Band	Uplink (MHz)	Downlink (MHz)
LTE Band 2	1850 - 1910	1930 - 1990
LTE Band 4	1710 - 1755	2110 - 2155
LTE Band 12	699 - 716	729 - 746

Band	Bandwidth					
	1.4 MHz	3 MHz	5 MHz	10 MHz	15 MHz	20 MHz
LTE Band 2	X	X	X	X	X	X
LTE Band 4	X	X	X	X	X	X
LTE Band 12	X	X	X	X		

5.2 Conducted TX Power

Designers should review latest M14A2A Hardware Design Guidelines to ensure the information is up to date.

Band	Items	Parameter	Unit	Min.	Typ.	Max.
LTE Band 2	Max TX Power	10 MHz 12RBs/QPSK	dBm	20.3	23	25.7
LTE Band 4	Max TX Power	10 MHz 12RBs/QPSK	dBm	20.3	23	25.7
LTE Band 12	Max TX Power	10 MHz 12RBs/QPSK	dBm	20.3	23	25.7

5.3 Conducted RX Sensitivity

Designers should review latest M14A2A Hardware Design Guidelines to ensure the information is up to date.

Band	Items	Parameter	Unit	Min.	Typ.	Max.
LTE Band 2	Receive Sensitivity	10 MHz with 50 RBs	dBm		-96.3	-94.3
LTE Band 4	Receive Sensitivity	10 MHz with 50 RBs	dBm		-98.3	-96.3
LTE Band 12	Receive Sensitivity	10 MHz with 50 RBs	dBm		-95.3	-93.3

5.4 Primary Antenna Requirements

Designers should review latest M14A2A Hardware Design Guidelines to ensure the information is up to date.

PRIMARY ANTENNA REQUIREMENTS	
Frequency Range	Depending on the frequency bands provided by the network operator, the customer shall use the most suitable antenna for those bands
Bandwidth	LTE B2(1900): 62MHz LTE B4(1700): 45MHz LTE B12(700a): 17MHz
Impedance	50 ohm
Input Power	>24 dBm

5.5 Diversity Antenna Requirements

Designers should review latest M14A2A Hardware Design Guidelines to ensure the information is up to date.

RX DIVERSITY ANTENNA REQUIREMENTS	
Frequency Range	Depending on the frequency bands provided by the network operator, the customer shall use the most suitable antenna for those bands
Bandwidth	LTE B2(1900): 62MHz LTE B4(1700): 45MHz LTE B12(700c): 17MHz
Impedance	50 ohm

5.6 Recommended Antennas

Type	Manufacturer	Part Number
Primary & Diversity	Taoglas ¹	TG.30.8113

Note 1: U.FL to SMA adapter required.

For applications not using the recommended antennas developers will need to ensure that the selected antenna(s) must meet the following gain requirements:

LTE Band	Max Gain (dBi)
LTE B2(1900)	9.5 dBi
LTE B4(1700)	6.5 dBi
LTE B12(700)	10.1 dBi

6. Certifications

6.1 Carrier Specific

NL-SW-LTE-WM14 AT&T MBA

6.2 Geography Specific

Federal Communications Commission (FCC47) part 22, 24
Complies with FCC47 Part 15 Class B Radiated and Conducted Emissions

7. Federal Regulatory Licensing

7.1 Export Control Classification Number (ECCN)

ECCNs are five character alpha-numeric designations used on the Commerce Control List (CCL) to identify dual-use items for export control purposes. An ECCN categorizes items based on the nature of the product, i.e. type of commodity, software, or technology and its respective technical parameters.

NL-SW-LTE-WM14 (and all Skywire Modems): 5A992.a

7.2 Harmonized Tariff Schedule Code

HTS Code: 8517.62.0010

8. End Product Labeling Requirements

Device Uses Approved Radio: NL-SW-LTE-WM14

Contains FCC ID: NKRM14A2A and IC ID: Altair 1160.

This device complies with Part 15 of the FCC Rules. Operation is subject to the following two conditions: (1) This device may not cause harmful interferences, and (2) this device must accept any interference received, including interference that may cause undesired operation.