



**SPECIFICATIONS
FOR LCD MODULE**

MATRIX ORBITAL NO.	MOP-AL162A-xxxx-xxE-xxx MOP-AL162A-xxxx-xxJ-xxx
--------------------	--

DOCUMENT REVISION HISTORY:

DATE	PAGE	DESCRIPTION
1999.8.	-	First release
2005.3.	-	Modify the full specification
2005.12	-	Update the part number system
2006.03	-	Add Red Backlight

Contents

1. Precautions in use of LCD Modules
2. General Specification
3. Absolute Maximum Ratings
4. Electrical Characteristics
5. Optical Characteristics
6. Interface Pin Function
7. Power Supply
8. Contour Drawing & Block Diagram
9. Function Description
10. Character Generator ROM Pattern
11. Instruction Table
12. Timing Characteristics
13. Initializing of LCM
14. Quality Assurance
15. Reliability

1. Precautions in use of LCD Modules

- (1) Avoid applying excessive shocks to the module or making any alterations or modifications to it.
- (2) Don't make extra holes on the printed circuit board, modify its shape or change the components of LCD module.
- (3) Don't disassemble the LCM.
- (4) Don't operate it above the absolute maximum rating.
- (5) Don't drop, bend or twist LCM.
- (6) Soldering: only to the I/O terminals.
- (7) Storage: please storage in anti-static electricity container and clean environment.

2. General Specification

Item	Dimension	Unit
Number of Characters	16 characters x 2 Lines	□
Module dimension(No Backlight)	80.0 x 36.0 x 10.0□MAX□	mm
Module dimension(With LED Backlight)	80.0 x 36.0 x 14.0□MAX□	mm
View area	64.5 x 15.5	mm
Active area	56.20 x 11.50	mm
Dot size	0.55x 0.65	mm
Dot pitch	0.60 x 0.70	mm
Character size	2.95 x 5.55	mm
Character pitch	3.55 x 5.95	mm
LCD type	STN	
Duty	1/16	
View direction	6 o'clock or 12 o'clock	
Backlight Type	None, RED or YELLOW-GREEN or WHITE LED backlight	

3. Absolute Maximum Ratings

Item		Symbol	Min	Max	Unit
Input Voltage		V_I	-0.3	VDD+0.3	V
Supply Voltage For Logic		VDD-V _{SS}	-0.3	7.0	V
Supply Voltage For LCD		V _{DD} -V ₀	Vdd-13.5	0	V
Standard	Operating Temp.	Top	0	50	□
Temperature LCM	Storage Temp.	Tstr	-10	60	□
Wide Temperature	Operating Temp.	Top	-20	70	□
LCM	Storage Temp.	Tstr	-30	80	□

4. Electrical Characteristics

Item	Symbol	Condition	Min	Typ	Max	Unit
Supply Voltage For Logic	V _{DD} -V _{SS}	□	4.5	5.0	5.5	V
Supply Voltage For LCD	V _{DD} -V ₀	Ta=25□	4.5	5.0	5.5	V
Input High Volt.	V _{IH}	□	0.7 V _{DD}	□	V _{DD}	V
Input Low Volt.	V _{IL}	□	V _{SS}	□	0.3 V _{DD}	V
Supply Current	I _{DD}	V _{DD} =5V	0.8	1.2	1.5	mA
Supply Voltage of Yellow-green backlight	V _{LED}	Forward current =120 mA Number of LED die 2x12= 24	3.8	4.1	4.3	V
Supply Voltage of White backlight	V _{LED}	Forward current =40 mA Number of LED die 1x2= 2	4.5	4.8	5.2	V
Supply Voltage of Red backlight	V _{LED}	Forward current =120 mA Number of LED die 2x12= 24	3.5	3.9	4.1	V

5. Optical Characteristics

Item	Symbol	Condition	Min	Typ	Max	Unit
View Angle	(V) θ	CR \square 2	-20	\square	35	deg
	(H) ϕ	CR \square 2	-30	\square	30	deg
Contrast Ratio	CR	\square	\square	3	\square	\square
Response Time	T rise	\square	\square	\square	250	ms
	T fall	\square	\square	\square	250	ms

Definition of Operation Voltage (Vop)

Definition of Response Time (Tr, Tf)

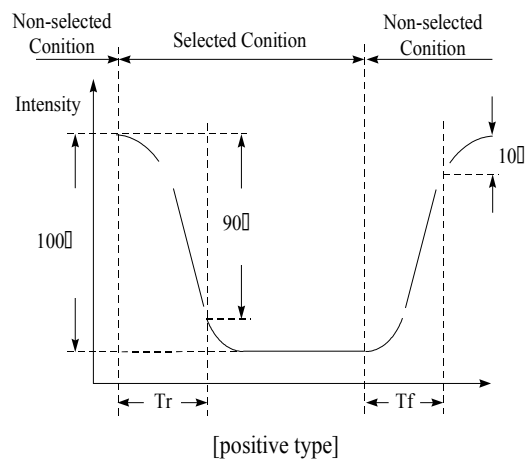
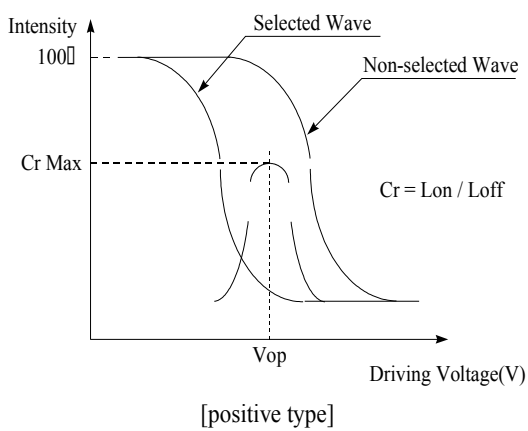

Conditions :

Operating Voltage : Vop

Viewing Angle(θ \square ϕ) : 0 \square 0 \square

Frame Frequency : 64 HZ

Driving Waveform : 1/N duty , 1/a bias

Definition of viewing angle(CR \square 2)

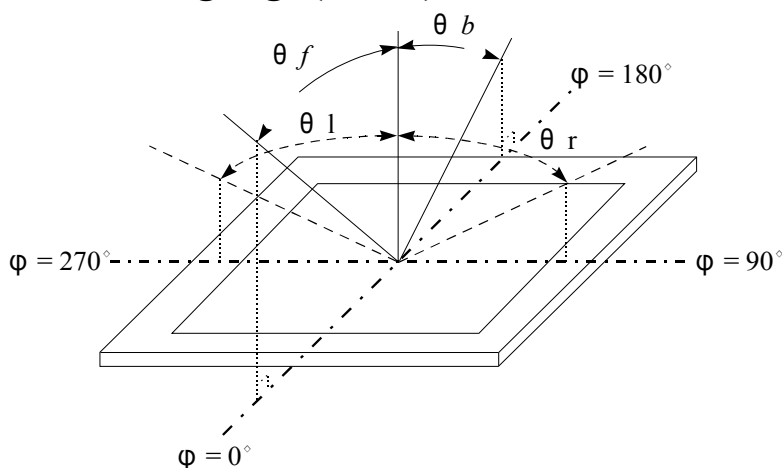

6. Interface Pin Function

Pin No.	Symbol	Level	Description
1	V _{SS}	0V	Ground
2	V _{DD}	5.0V	Supply Voltage for logic
3	V ₀	(Variable)	Operating voltage for LCD
4	RS	H/L	H: DATA, L: Instruction code
5	R/W	H/L	H: Read(MPU→Module) L: Write(MPU→Module)
6	E	H,H→L	Chip enable signal
7	DB0	H/L	Data bit 0
8	DB1	H/L	Data bit 1
9	DB2	H/L	Data bit 2
10	DB3	H/L	Data bit 3
11	DB4	H/L	Data bit 4
12	DB5	H/L	Data bit 5
13	DB6	H/L	Data bit 6
14	DB7	H/L	Data bit 7
15	LED(+)		Anode of LED Backlight
16	LED(-)		Cathode of LED Backlight

7. POWER SUPPLY

SINGLE SUPPLY VOLTAGE TYPE

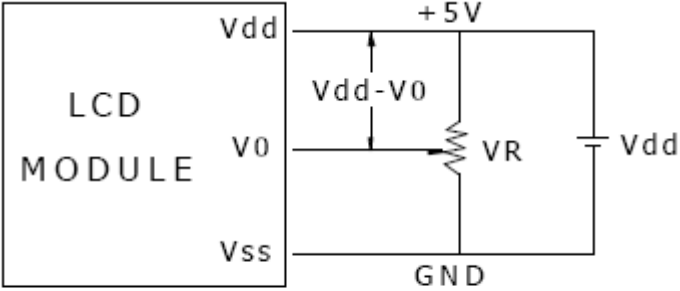

Vdd-V0: LCD Driving Voltage
VR: 10K - 20K

DUAL SUPPLY VOLTAGE TYPE

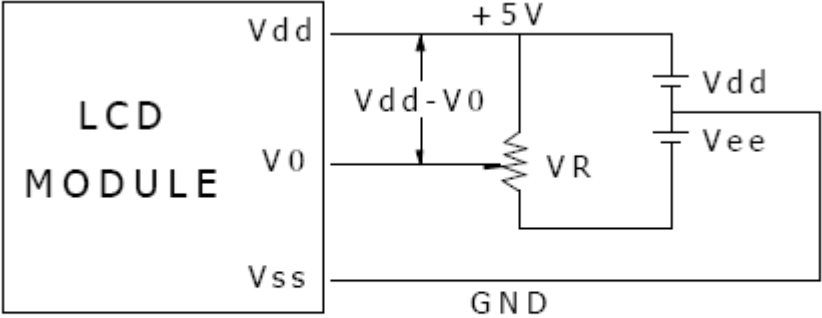

Vdd-V0: LCD Driving Voltage
VR: 10K - 20K

8. Contour Drawing & Block Diagram

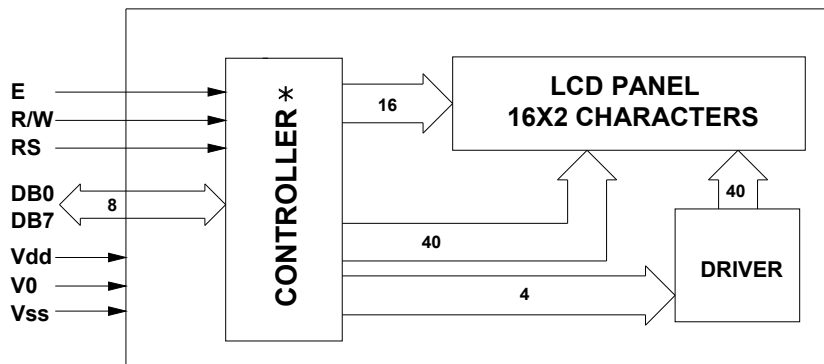
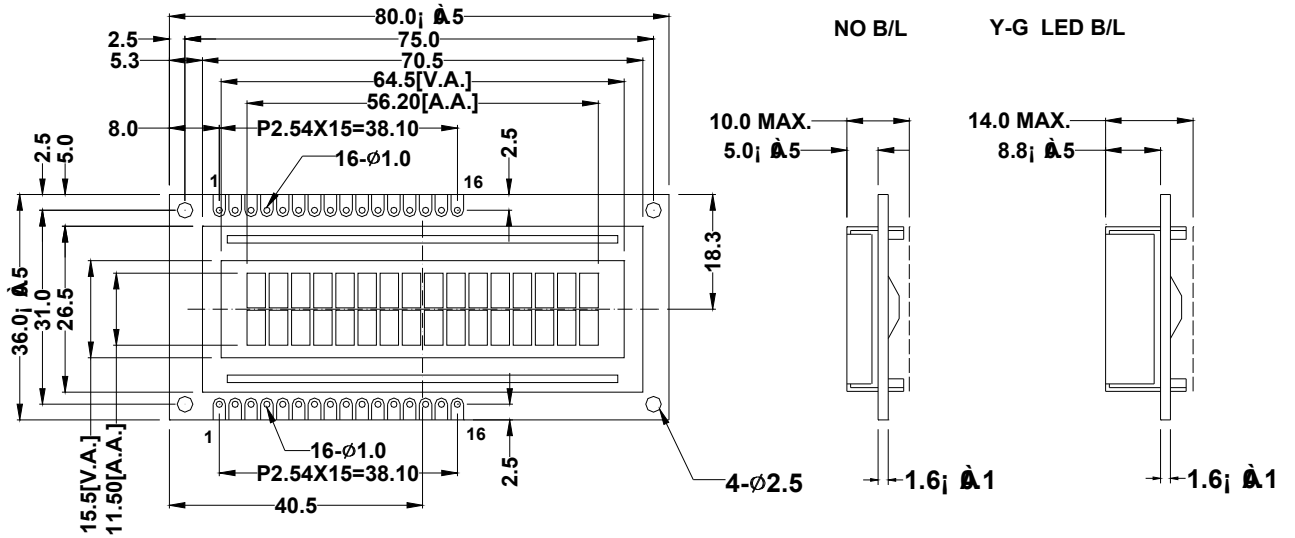

* S6A0069 OR EQUIVALENT

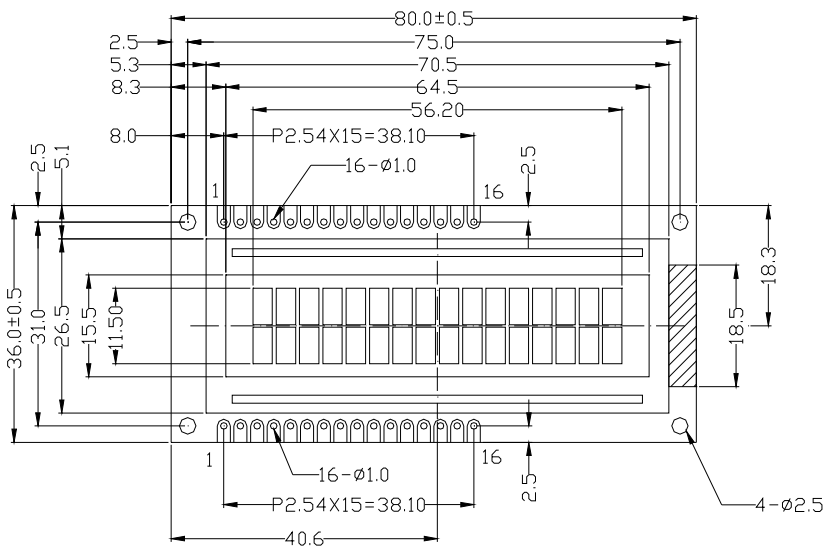
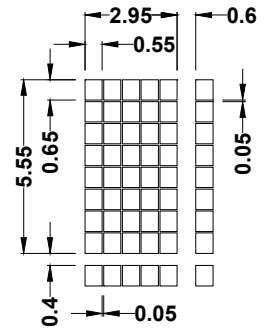

WITH WHITE LED BACKLIGHT

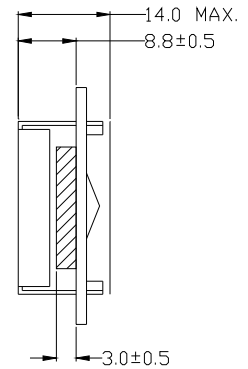

9. Function Description

The LCD display Module is built in a LSI controller, the controller has two 8-bit registers, an instruction register (IR) and a data register (DR).

The IR stores instruction codes, such as display clear and cursor shift, and address information for display data RAM (DDRAM) and character generator (CGRAM). The IR can only be written from the MPU. The DR temporarily stores data to be written or read from DDRAM or CGRAM. When address information is written into the IR, then data is stored into the DR from DDRAM or CGRAM. By the register selector (RS) signal, these two registers can be selected.

RS	R/W	Operation
0	0	IR write as an internal operation (display clear, etc.)
0	1	Read busy flag (DB7) and address counter (DB0 to DB7)
1	0	Write data to DDRAM or CGRAM (DR to DDRAM or CGRAM)
1	1	Read data from DDRAM or CGRAM (DDRAM or CGRAM to DR)

Busy Flag (BF)

When the busy flag is 1, the controller LSI is in the internal operation mode, and the next instruction will not be accepted. When RS=0 and R/W=1, the busy flag is output to DB7. The next instruction must be written after ensuring that the busy flag is 0.

Address Counter (AC)

The address counter (AC) assigns addresses to both DDRAM and CGRAM

Display Data RAM (DDRAM)

This DDRAM is used to store the display data represented in 8-bit character codes. Its extended capacity is 80×8 bits or 80 characters. Below figure is the relationships between DDRAM addresses and positions on the liquid crystal display.

AC
(hexadecimal)

Character Generator ROM (CGROM)

The CGROM generate 5×8 dot or 5×10 dot character patterns from 8-bit character codes. See Table 2.

Character Generator RAM (CGRAM)

In CGRAM, the user can rewrite character by program. For 5×8 dots, eight character patterns can be written, and for 5×10 dots, four character patterns can be written.

Write into DDRAM the character code at the addresses shown as the left column of table 1. To show the character patterns stored in CGRAM.

10. Character Generator ROM Pattern

Table.2 MOP-AL162A-xxxx-xxxE-xxx

Upper 4 bit / Lower 4 bit	LLLL	LLLH	LLHL	LLHH	LHLL	LHLH	LHHL	LHHH	HLLL	HLLH	HLHL	HLHH	HHLL	HHLH	HHHL	HHHH
LLLL	☐	士	☐	0	0	P	°	P	☐	☐	☐	☐	☐	☐	☐	☐
LLLH	☐	≡	!	1	A	Q	9	Q	☐	☐	☐	☐	J	+	Y	0
LLHL	☐	7	"	2	B	R	B	r	☐	☐	☐	☐	°	☐	☐	☐
LLHH	☐	△	#	3	C	S	C	☐	☐	☐	☐	☐	☐	☐	☐	☐
LHLL	☐	7	*	4	D	T	D	+	☐	☐	☐	☐	☐	☐	☐	☐
LHLH	☐	7	×	5	E	U	E	U	☐	☐	☐	☐	☐	☐	☐	☐
LHHL	☐	7	⊗	6	F	V	F	V	☐	☐	☐	☐	☐	☐	☐	☐
LHHH	☐	J	7	7	G	W	G	W	☐	☐	☐	☐	☐	☐	☐	☐
HLLL	☐	J	0	8	H	×	H	×	☐	☐	☐	☐	☐	☐	☐	☐
HLLH	☐	7	0	9	I	Y	I	Y	☐	☐	☐	☐	☐	☐	☐	☐
HLHL	☐	☐	☐	*	J	Z	J	Z	☐	☐	☐	☐	☐	☐	☐	☐
HLHH	☐	J	+	*	K	C	K	C	☐	☐	☐	☐	☐	☐	☐	☐
HHLL	☐	≡	*	<	☐	∖	☐	∖	☐	☐	☐	☐	☐	☐	☐	☐
HHLH	☐	☐	☐	☐	M	J	m	J	☐	☐	☐	☐	☐	☐	☐	☐
HHHL	☐	☐	☐	>	N	^	n	^	☐	☐	☐	☐	☐	☐	☐	☐
HHHH	☐	☐	☐	?	0	☐	☐	☐	☐	☐	☐	☐	☐	☐	☐	☐

Table 3. MOP-AL162A-xxxx-xxJ-xxx

					D7	0	0	0	0	0	0	0	1	1	1	1	1	1	1	1	
					D6	0	0	0	0	1	1	1	1	0	0	0	0	1	1	1	1
					D5	0	0	1	1	0	0	1	1	0	0	1	1	0	0	1	1
					D4	0	1	0	1	0	1	0	1	0	1	0	1	0	1	0	1
D3	D2	D1	D0		0	1	2	3	4	5	6	7	8	9	A	B	C	D	E	F	
0	0	0	0	0				0	a	P	\	P				-	9	E	o	P	
0	0	0	1	1			!	1	Q	a	a				=	7	+	4	a	9	
0	0	1	0	2			"	2	R	b	r				「	イ	ウ	×	E	6	
0	0	1	1	3			#	3	S	c	s				」	ウ	テ	E	s	*	
0	1	0	0	4			\$	4	T	d	t				\	I	ト	†	H	Q	
0	1	0	1	5			%	5	U	e	u				.	オ	†	1	s	Q	
0	1	1	0	6			&	6	V	f	v				ヲ	カ	ニ	ヨ	Σ		
0	1	1	1	7			'	7	W	g	w				フ	キ	ヲ	ヲ	9	π	
1	0	0	0	8			(8	X	h	x				イ	ク	ヲ	リ	J	又	
1	0	0	1	9)	9	Y	i	y				オ	ト	ノ	ル	リ	ウ	
1	0	1	0	A			*	:	J	Z	j	z			エ	コ	ノ	ル	リ	ヲ	
1	0	1	1	B			+	:	K	L	k	l			ス	ヲ	ヒ	ロ	°	ヲ	
1	1	0	0	C			,	<	L	#	l	#			ト	ヨ	フ	ヲ	ト	ヲ	
1	1	0	1	D			-	=	N	I	n	i			エ	ズ	ノ	リ	ト	ト	
1	1	1	0	E			.	>	N	^	n	^			ヨ	エ	ト	ト	°	ヲ	
1	1	1	1	F			/	?	O	_	o	_			ウ	リ	ヲ	°	ト	■	

11. Instruction Table

Instruction	Instruction Code										Description	Execution time (fosc=270Khz)	
	RS	R/W	DB7	DB6	DB5	DB4	DB3	DB2	DB1	DB0			
Clear Display	0	0	0	0	0	0	0	0	0	1	Write "00H" to DDRAM and set DDRAM address to "00H" from AC	1.53ms	
Return Home	0	0	0	0	0	0	0	0	0	1	□	Set DDRAM address to "00H" from AC and return cursor to its original position if shifted. The contents of DDRAM are not changed.	1.53ms
Entry Mode Set	0	0	0	0	0	0	0	0	1	I/D	SH	Assign cursor moving direction and enable the shift of entire display.	39μs
Display ON/OFF Control	0	0	0	0	0	0	0	1	D	C	B	Set display (D), cursor (C), and blinking of cursor (B) on/off control bit.	39μs
Cursor or Display Shift	0	0	0	0	0	0	1	S/C	R/L	□	□	Set cursor moving and display shift control bit, and the direction, without changing of DDRAM data.	39μs
Function Set	0	0	0	0	1	DL	N	F	□	□	□	Set interface data length (DL:8-bit/4-bit), numbers of display line (N:2-line/1-line)and, display font type (F:5×11 dots/5×8 dots)	39μs
Set CGRAM Address	0	0	0	1	AC5	AC4	AC3	AC2	AC1	AC0	AC0	Set CGRAM address in address counter.	39μs
Set DDRAM Address	0	0	1	AC6	AC5	AC4	AC3	AC2	AC1	AC0	AC0	Set DDRAM address in address counter.	39μs
Read Busy Flag and Address	0	1	BF	AC6	AC5	AC4	AC3	AC2	AC1	AC0	AC0	Whether during internal operation or not can be known by reading BF. The contents of address counter can also be read.	0μs
Write Data to RAM	1	0	D7	D6	D5	D4	D3	D2	D1	D0	D0	Write data into internal RAM (DDRAM/CGRAM).	43μs
Read Data from RAM	1	1	D7	D6	D5	D4	D3	D2	D1	D0	D0	Read data from internal RAM (DDRAM/CGRAM).	43μs

□ "□"□don't care

12. Timing Characteristics

12.1 Write Operation

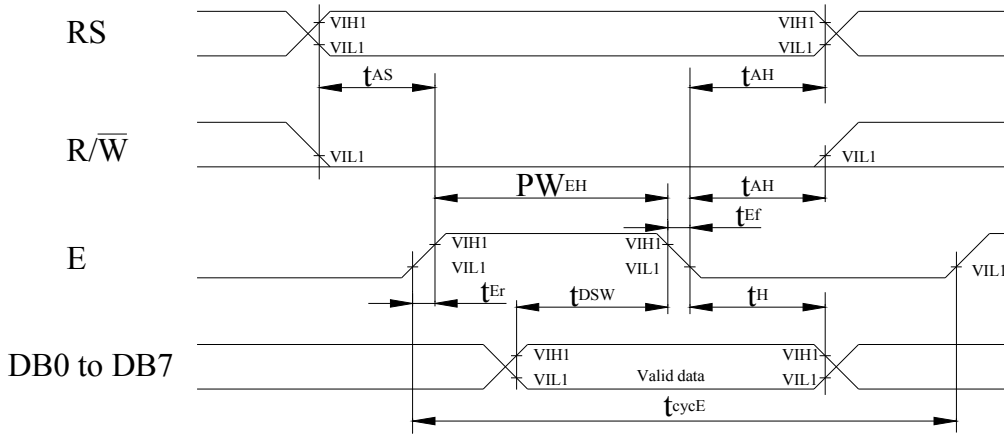

$T_a=25^\circ, V_{DD}=5.0\pm 0.5V$

Item	Symbol	Min	Typ	Max	Unit
Enable cycle time	t_{cycE}	1200	□	□	ns
Enable pulse width (high level)	PW_{EH}	140	□	□	ns
Enable rise/fall time	t_{Er}, t_{Ef}	□	□	25	ns
Address set-up time (RS, R/W to E)	t_{AS}	0	□	□	ns
Address hold time	t_{AH}	10	□	□	ns
Data set-up time	t_{DSW}	40	□	□	ns
Data hold time	t_H	10	□	□	ns

12.2 Read Operation

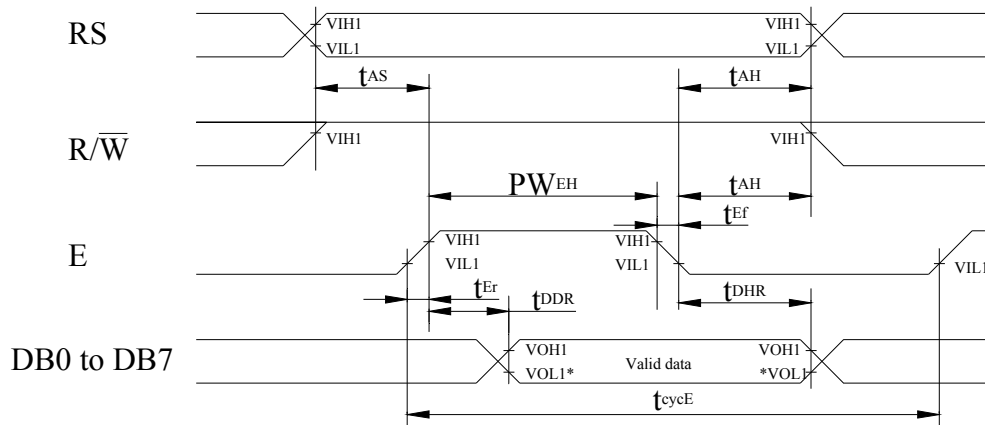

NOTE: *VOL1 is assumed to be 0.8V at 2 MHz operation.

$T_a=25^\circ\text{C}$, $V_{DD}=5.0\pm 0.5\text{V}$

Item	Symbol	Min	Typ	Max	Unit
Enable cycle time	t_{cycE}	1200	□	□	ns
Enable pulse width (high level)	PW_{EH}	140	□	□	ns
Enable rise/fall time	$t_{\text{Er}}, t_{\text{Ef}}$	□	□	25	ns
Address set-up time (RS, R/W to E)	t_{AS}	0	□	□	ns
Address hold time	t_{AH}	10	□	□	ns
Data delay time	t_{DDR}	□	□	100	ns
Data hold time	t_{DHR}	10	□	□	ns

12.3 Timing Diagram of VDD Against V0.

Power on sequence shall meet the requirement of Figure 4, the timing diagram of VDD against V0.

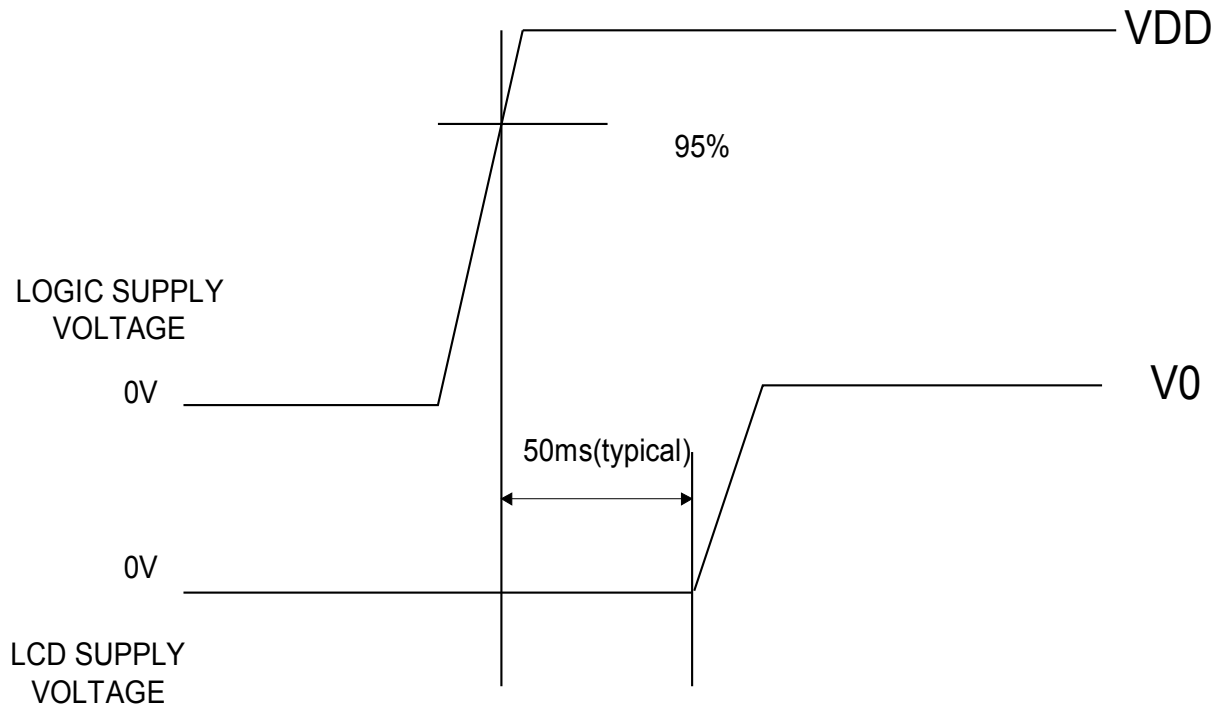

13.Initializing of LCM

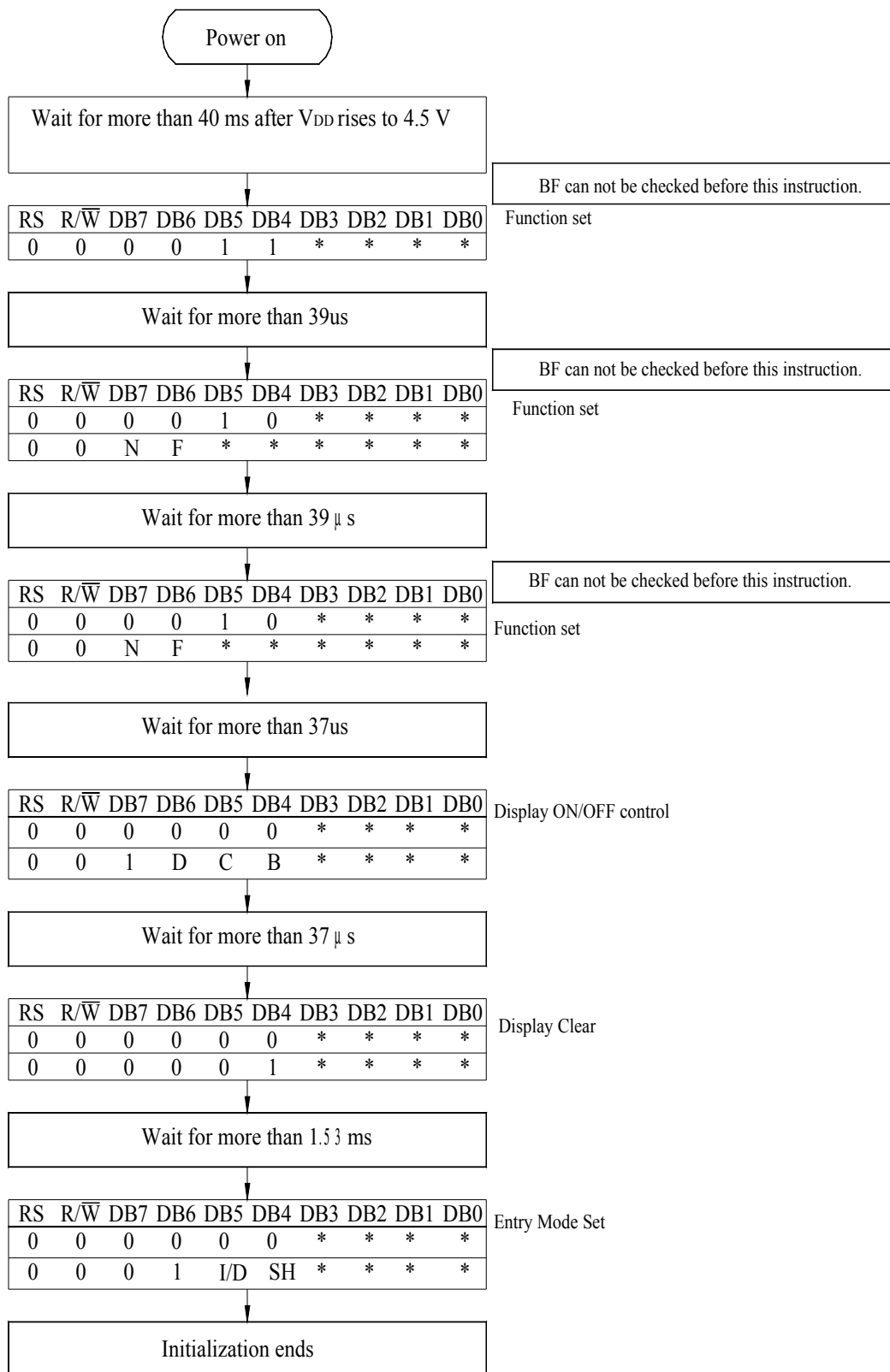

4-Bit Inerface

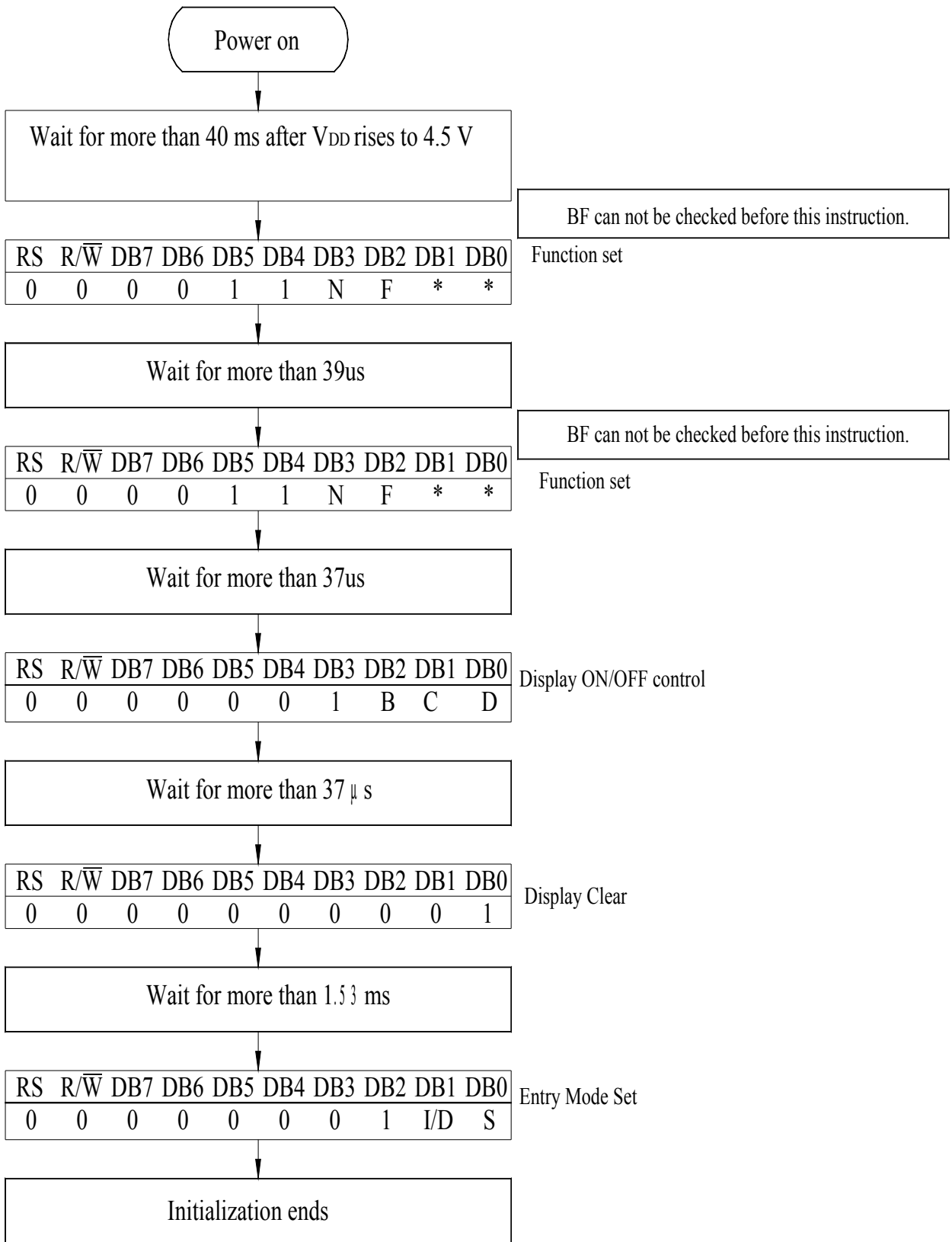

8-Bit Ineterface

14.Quality Assurance

Screen Cosmetic Criteria

Item	Defect	Judgment Criterion	Partition
1	Spots	<p>A)Clear</p> <p><u>Size: d mm</u> <u>Acceptable Qty in active area</u></p> <p>d \leq 0.1 Disregard</p> <p>0.1 < d \leq 0.2 6</p> <p>0.2 < d \leq 0.3 2</p> <p>0.3 < d 0</p> <p>Note: Including pin holes and defective dots which must be within one pixel size.</p> <p>B)Unclear</p> <p><u>Size: d mm</u> <u>Acceptable Qty in active area</u></p> <p>d \leq 0.2 Disregard</p> <p>0.2 < d \leq 0.5 6</p> <p>0.5 < d \leq 0.7 2</p> <p>0.7 < d 0</p>	Minor
2	Bubbles in Polarizer	<p><u>Size: d mm</u> <u>Acceptable Qty in active area</u></p> <p>d \leq 0.3 Disregard</p> <p>0.3 < d \leq 1.0 3</p> <p>1.0 < d \leq 1.5 1</p> <p>1.5 < d 0</p>	Minor
3	Scratch	In accordance with spots cosmetic criteria. When the light reflects on the panel surface, the scratches are not to be remarkable.	Minor
4	Allowable Density	Above defects should be separated more than 30mm each other.	Minor
5	Coloration	<p>Not to be noticeable coloration in the viewing area of the LCD panels.</p> <p>Back-light type should be judged with back-light on state only.</p>	Minor

15. Reliability

Content of Reliability Test

Environmental Test			
Test Item	Content of Test	Test Condition	Applicable Standard
High Temperature storage	Endurance test applying the high storage temperature for a long time.	60□ 96hrs	—
Low Temperature storage	Endurance test applying the high storage temperature for a long time.	-10□ 96hrs	—
High Temperature Operation	Endurance test applying the electric stress (Voltage & Current) and the thermal stress to the element for a long time.	50□ 96hrs	—
Low Temperature Operation	Endurance test applying the electric stress under low temperature for a long time.	0□ 96hrs	—
High Temperature/ Humidity Storage	Endurance test applying the high temperature and high humidity storage for a long time.	60□,90%RH 96hrs	—
High Temperature/ Humidity Operation	Endurance test applying the electric stress (Voltage & Current) and temperature / humidity stress to the element for a long time.	50□,90%RH 96hrs	—

Temperature Cycle	<p>Endurance test applying the low and high temperature cycle.</p> <p>-10°C 25°C 60°C</p> <p>30min 5min 30min</p> <p>1 cycle</p>	-10°C/60°C	10 cycles	—	
Mechanical Test					
Vibration test	Endurance test applying the vibration during transportation and using.	10~22Hz→1.5mmp-p	22~500Hz→1.5G	Total 0.5hrs	—
Shock test	Constructional and mechanical endurance test applying the shock during transportation.	50G Half sign	wave 11 msdc	3 times of each direction	—

***Supply voltage for logic system=5V. Supply voltage for LCD system =Operating voltage at 25°C