

# **BSIO**

## **Peripheral Board**

### **Technical Manual**

Date: 11 October, 2005

Document Revision: 1.01



**BiPOM Electronics**

16301 Blue Ridge Road, Missouri City, Texas 77489  
Telephone: 1-713-283-9970. Fax: 1-281-416-2806  
E-mail: [info@bipom.com](mailto:info@bipom.com)  
Web: [www.bipom.com](http://www.bipom.com)

© 1996-2005 by BiPOM Electronics. All rights reserved.

BSIO Peripheral Board Technical Manual. No part of this work may be reproduced in any manner without written permission of BiPOM Electronics.

All trademarked names in this manual are the property of respective owners.

#### WARRANTY:

BiPOM Electronics warrants BSIO board for a period of 1 year. If the board becomes defective during this period, BiPOM will at its option, replace or repair the board. This warranty is voided if the product is subjected to physical abuse or operated outside stated electrical limits. BiPOM Electronics will not be responsible for damage to any external devices connected to BSIO board. BiPOM Electronics disclaims all warranties express or implied warranties of merchantability and fitness for a particular purpose. In no event shall BiPOM Electronics be liable for any indirect, special, incidental or consequential damages in connection with or arising from the use of this product. BiPOM Electronics' liability is limited to the purchase price of this product.

## 1. Overview

BSIO peripheral board is part of MicroTRAK training kit for use with BASIC Stamp Carrier board (BSCB-1 or BSCB-2) and a BS2xx BASIC Stamp Module.

MicroTRAK is the ultimate training kit and project development platform with microcontrollers. Whether developing a new project with or learning about microcontrollers, you will find MicroTRAK a highly versatile carrier board with support for microcontroller systems with 8051, 6811, 6808, PIC, Basic Stamp, Basic Tiger and others.

List of micro-controller boards and peripheral boards, software examples for MicroTRAK training kit are available from

<http://www.bipom.com>

BSIO board allows access to any signal of any port of a BASIC Stamp micro-controller on the MicroTRAK development platform with any BSCB and also access to signals of PIC16F818 on BSCB-2. BSIO board has 24 switches to force BASIC Stamp ports to a particular value and 24 LED's to indicate the port statuses.

BSIO board is powered from a 5 Volt DC external stabilized power source through the 36-pin input/output connector.

## 2. Specifications

BSIO peripheral board has the following configuration:

- 36-pin pluggable module connector
- Two 32-pin expansion connectors
- 24 channel DIP switches to force ports to a particular state ( low or high )
- 24 LED's with 74ALS05 hex inverters as input buffers
- Audio Amplifier (LM386)
- 10K Potentiometer with RC circuit
- 1-wire interface 3-pin connector
- Single operating stabilized voltage 5VDC at 200mA maximum current
- Dimensions are 5.95 X 1.975 inches (15.1 X 5.0 centimeters).
- Mounting holes of 0.15 inches (3.8 millimeters) are on four corners.
- 0° - 70° C operating, -40° - +85° C storage temperature range.

### 3. Functional Blocks

Figure 1 shows the block diagram of the BSIO peripheral board

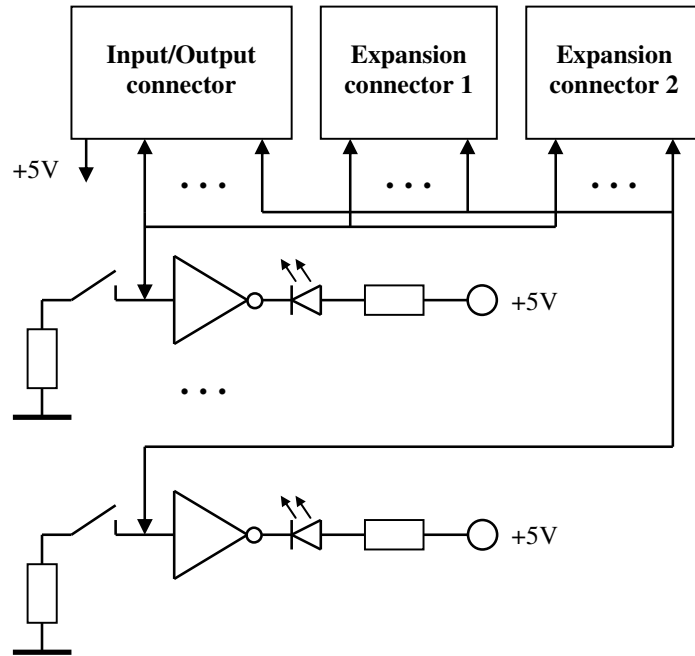

Figure 1

#### Pluggable Module connector

The 32 input/output (I/O) lines and 5 Volt power supply pins are available on the 36-pin connector X1 for interfacing to BSCB board.

Table 1 shows the pin assignments for the connector.

Connector X1

Signal	Pin	Signal	Pin	Signal	Pin	Signal	Pin
GND	1	P8	10	P0	19	N2	28
VCC	2	RA7	11	P1	20	N3	29
P15	3	RA6	12	P2	21	N4	30
P14	4	RA5	13	P3	22	N5	31
P13	5	RB0	14	P4	23	N6	32
P12	6	RB3	15	P5	24	N7	33
P11	7	RB5	16	P6	25	N8	34
P10	8	RB6	17	P7	26	VCC	35
P9	9	RB7	18	N1	27	GND	36

Table 1

### **Expansion connectors**

The 32 input/output (I/O) lines are available on the 32-pin expansion connector X2 and X3 for interfacing to a microcontroller-board. Table 2 shows the pin assignments for the connector.

**Connectors X2, X3**

Signal	Pin		Signal	Pin		Signal	Pin		Signal	Pin
P15	1		RA7	9		P0	17		N1	25
P14	2		RA6	10		P1	18		N2	26
P13	3		RA5	11		P2	19		N3	27
P12	4		RB0	12		P3	20		N4	28
P11	5		RB3	13		P4	21		N5	29
P10	6		RB5	14		P5	22		N6	30
P9	7		RB6	15		P6	23		N7	31
P8	8		RB7	16		P7	24		N8	32

Table 2

### **Power Supply**

External power supply should be regulated 5 Volts DC at 200mA. Correct polarity should be observed when applying external DC supply to the connector.

## **4. Application Notes**

BSCB-1 and BSCB-2 are compatible with the following BASIC Stamp Modules:

**BS2-IC**  
**BS2e-IC**  
**BS2sx-IC**  
**BS2p-IC**  
**BS2pe-IC**

Audio Amplifier (LM386) on the BSIO board can be used with "FREQOUT" command. A small loudspeaker ( 8 ohms, 0.5 Watts ) can be connected to X4 output of BSIO to experiment with sound and frequency generation capabilities of the BASIC Stamp.

RC-circuit with 10K Potentiometer on connector J1 demonstrates the "RCTIME" command of the BASIC Stamp.

BSIO board has the special 2-pin connector for use with 1-wire Dallas Semiconductor devices using "OWIN" and "OWOUT" commands of the BASIC Stamp.

For detailed information on BS2 Modules, refer to Parallax

***<http://www.parallaxinc.com>***

Various BASIC Stamp Example programs can be downloaded from

***<http://www.bipom.com/bscbsoft.shtm>***

## 5. Board Layout

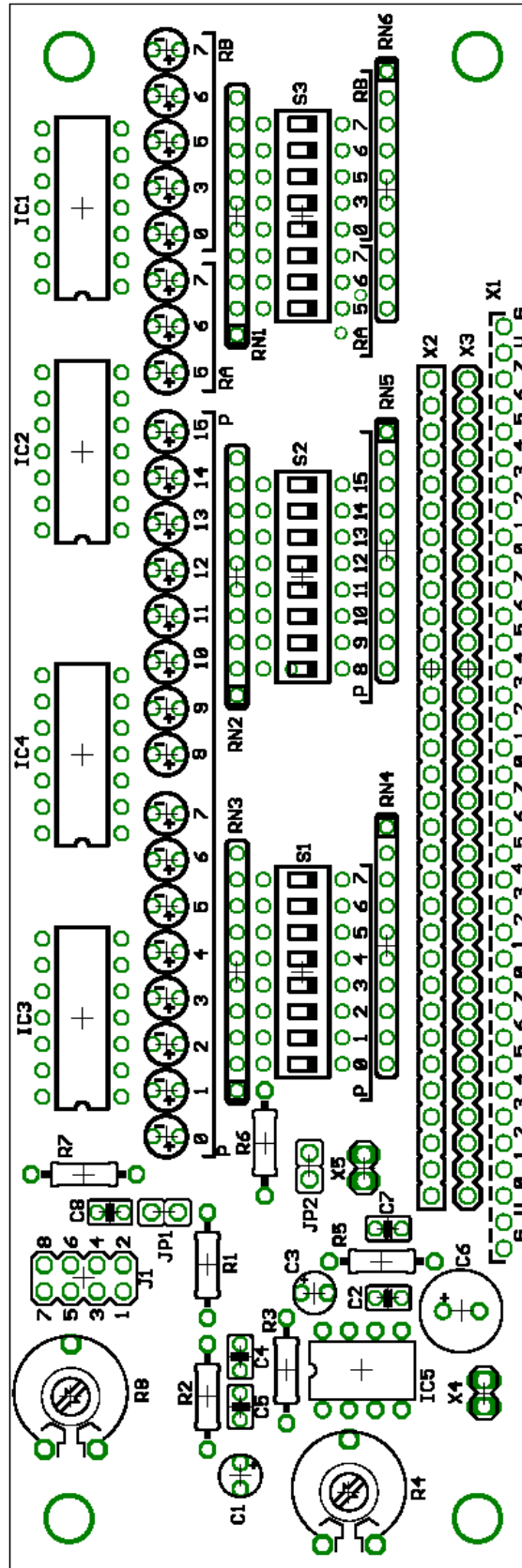

# 6. Schematics

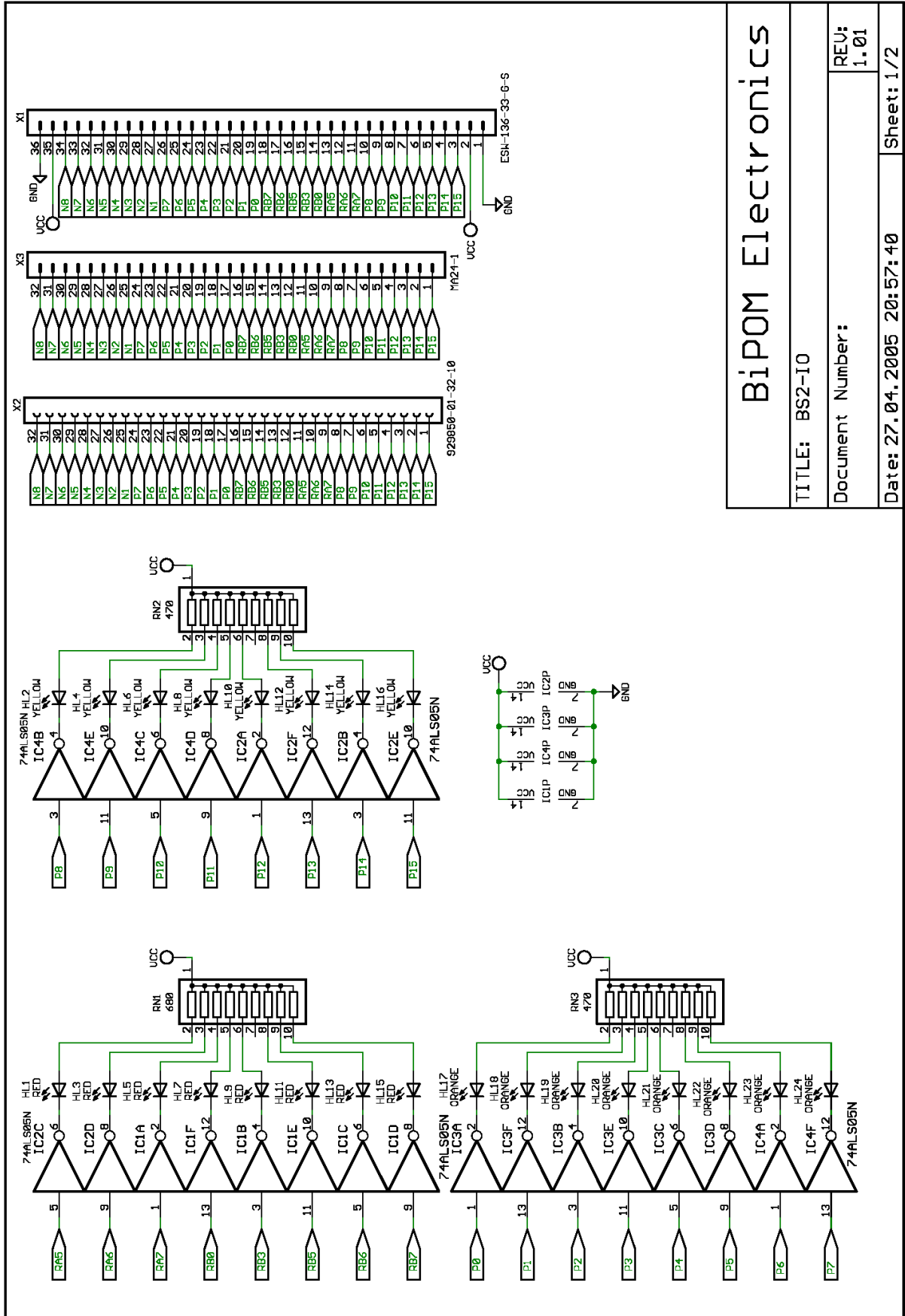

<b>BiPOM Electronics</b>	
TITLE: BS2-I0	
Document Number:	
REV: 1.01	Sheet: 1/2

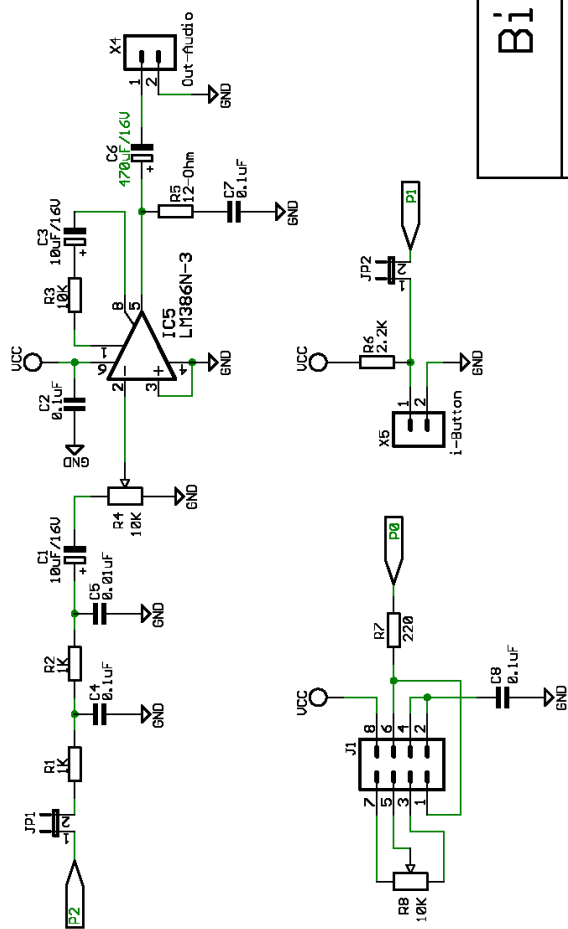
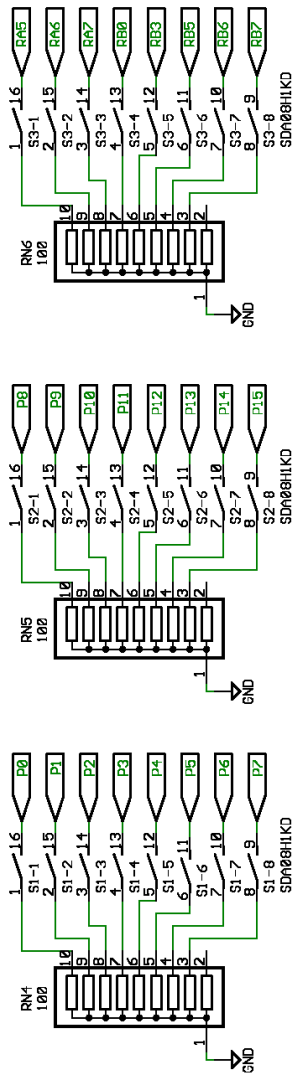

<b>BiPOM Electronics</b>	
TITLE: BS2-I0	
Document Number:	REV: 1.01
Date: 27.04.2005 20:57:40	Sheet: 2/2