

**MINI-MAX/ARM-C
and
MINI-MAX/ARM-E**

**Single Board Computers
Technical Manual**

Date: 09 January, 2012

Document Revision: 1.05



BiPOM Electronics

16301 Blue Ridge Road, Missouri City , Texas 77489
Telephone: 1-713-283-9970. Fax: Fax: 1-281-416-2806
E-mail: info@bipom.com
Web: www.bipom.com

© 1996-2006 by BiPOM Electronics. All rights reserved.

MINI-MAX/ARM Single Board Computer Technical Manual. No part of this work may be reproduced in any manner without written permission of BiPOM Electronics.

All trademarked names in this manual are the property of respective owners.

WARRANTY:

BiPOM Electronics warrants MINI-MAX/ARM for a period of 1 year. If the board becomes defective during this period, BiPOM will at its option, replace or repair the board. This warranty is voided if the product is subjected to physical abuse or operated outside stated electrical limits. BiPOM Electronics will not be responsible for damage to any external devices connected to MINI-MAX/ARM. BiPOM Electronics disclaims all warranties express or implied warranties of merchantability and fitness for a particular purpose. In no event shall BiPOM Electronics be liable for any indirect, special, incidental or consequential damages in connection with or arising from the use of this product. BiPOM Electronics' liability is limited to the purchase price of this product.

TABLE OF CONTENTS

1. OVERVIEW	4
2. SPECIFICATIONS	5
3. FUNCTIONAL BLOCKS	5
4. PERIPHERALS	14
5. SOFTWARE	14
6. BOARD LAYOUT	15
7. SCHEMATICS	16

1. Overview

MINI-MAX/ARM-C and MINI-MAX/ARM-E are general purpose, low-cost, highly-reliable and highly-expandable micro-controller systems, based on Philips LPC213x 32/16 bit ARM7TDMI-S CPU with real-time emulation and embedded trace support. MINI-MAX/ARM-E provides 10-TBASE Ethernet port.

CPU features.

- 16/32-bit ARM7TDMI-S microcontroller in a tiny LQFP64 package.
- 8/16/32 KB of on-chip static RAM and 32/64/128/256/512 KB of on-chip Flash program memory. 128 bit wide interface/accelerator enables high speed 60 MHz operation.
- In-System/In-Application Programming (ISP/IAP) via on-chip boot-loader software. Single Flash sector or full chip erase in 400 ms and programming of 256 bytes in 1 ms.
- Embedded ICE RT and Embedded Trace interfaces offer real-time debugging with the on-chip Real Monitor software and high speed tracing of instruction execution.
- One (LPC2131/32) or two (LPC2134/36/38) 8 channel 10-bit A/D converters provides a total of up to 16 analog inputs, with conversion times as low as 2.44 ms per channel.
- Single 10-bit D/A converter provides variable analog output (LPC2132/34/36/38).
- Two 32-bit timers/external event counters (with four capture and four compare channels each), PWM unit (six outputs) and watchdog.
- Low power Real-time clock with independent power and dedicated 32 kHz clock input.
- Multiple serial interfaces including two UART's (16C550), two Fast I2C-bus (400 kbit/s), SPI and SSP with buffering and variable data length capabilities.
- Vectored interrupt controller with configurable priorities and vector addresses.
- Up to 47 5 V tolerant general purpose I/O pins in tiny LQFP64 package.
- Up to nine edge or level sensitive external interrupt pins available.
- 60 MHz maximum CPU clock available from programmable on-chip PLL with settling time of 100 ms.
- On-chip integrated oscillator operates with external crystal in range of 1 MHz to 30 MHz and with external oscillator up to 60 MHz.
- Power saving modes include Idle and Power-down.
- Individual enable/disable of peripheral functions as well as peripheral clock scaling down for additional power optimization.
- Processor wake-up from Power-down mode via external interrupt or BOD.
- Single power supply chip with POR and BOD circuits:
- CPU operating voltage range of 3.0 V to 3.6 V ($3.3 \text{ V} \pm 10 \%$) with 5V tolerant I/O pins.

MINI-MAX/ARM boards complement these features, providing

- 14.7456 MHz crystal to achieve 58.9824 MHz core
- Microchip ENC28J60 Ethernet controller with network interface (MINI-MAX/ARM-E only).
- 8 Mbit serial FLASH memory
- Two RS232 Serial Ports
- Second CPU, allowing In-circuit Programming of main CPU through the serial port
- JTAG programming interface
- Keypad connector
- LCD connector (programmable contrast adjustment for the LCD)
- Screw terminal block for analog circuits.
- Expansion bus interface to low-cost peripheral boards
- Separate power supplies for 5V and 3.3V, digital and analog circuits.
- 32 KHz crystal and a 3 Volt lithium battery, which allows Real Time Clock unit to operate in the absence of external power.

2. Specifications

Dimensions are 2.35 X 2.40 inches (5.97 X 6.10 centimeters).
Mounting holes of 0.125 inches (3 millimeters) on four corners.
0° - 70°C operating, -40° - +85° C storage temperature range.

3. Functional Blocks

Figure1. Block diagram of the MINI-MAX/ARM system.

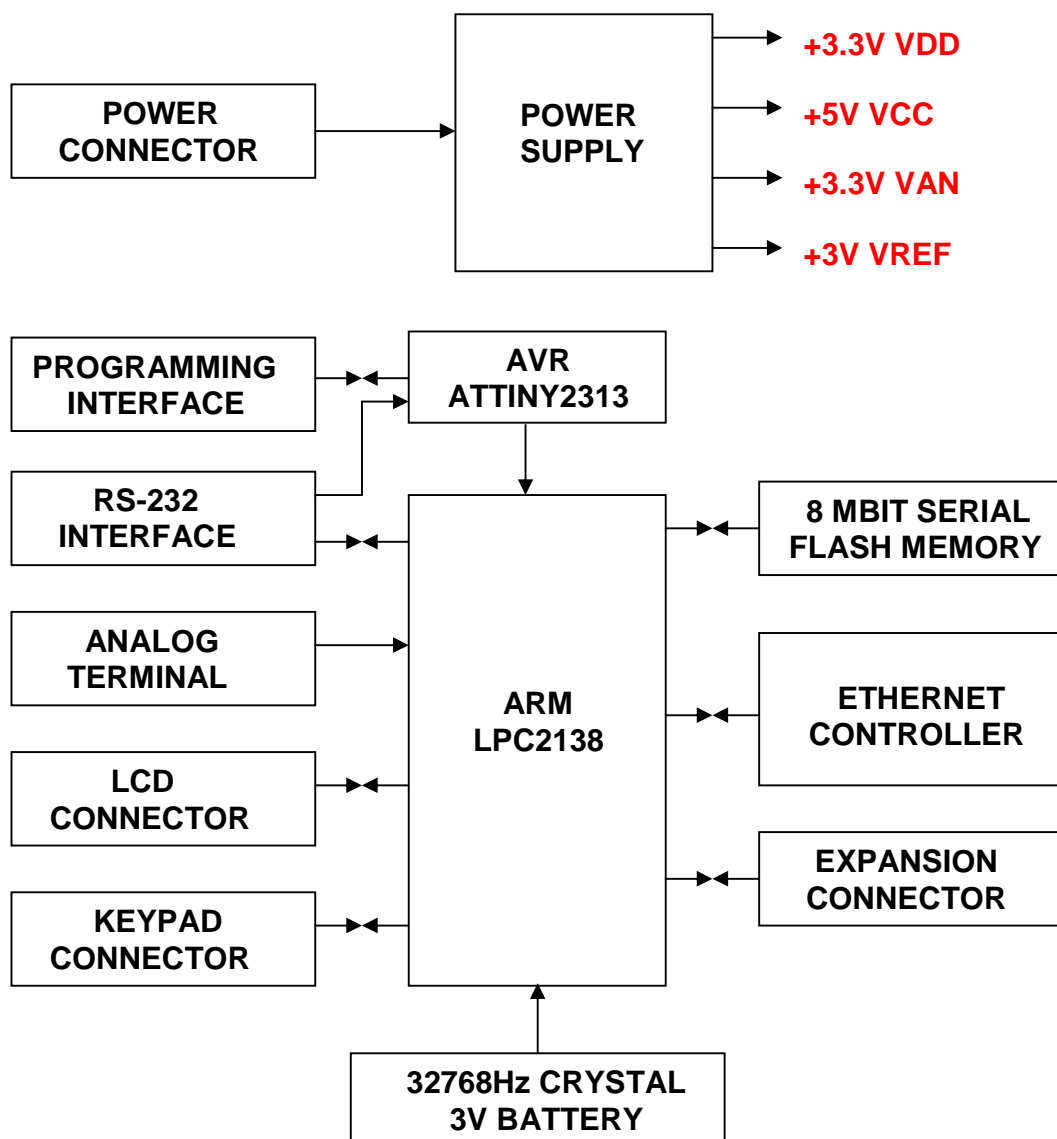

Micro-controller

The LPC2131/2132/2134/2136/2138 micro-controllers are based on a 32/16 bit ARM7TDMI-S CPU with real-time emulation and embedded trace support, that combines the micro-controller with 32/ 64/128/ 256/ 512 KB of embedded high speed Flash memory. A 128-bit wide memory interface and a unique accelerator architecture enable 32-bit code execution at maximum clock rate. For critical code size applications, the alternative 16-bit Thumb mode reduces code by more than 30 % with minimal performance penalty.

Due to their tiny size and low power consumption, these micro-controllers are ideal for applications where miniaturization is a key requirement, such as access control and point-of-sale. With a wide range of serial communications interfaces and on-chip SRAM options of 8/16/32 KB, they are very well suited for communication gateways and protocol converters, soft modems, voice recognition and low end imaging, providing both large buffer size and high processing power. Various 32-bit timers, single or dual 10-bit 8 channel ADC(s), 10-bit DAC, PWM channels and 47 GPIO lines with up to nine edge or level sensitive external interrupt pins make these micro-controllers particularly suitable for industrial control and medical systems. For detailed information please refer here:

<http://www.semiconductors.philips.com/pip/LPC2134FBD64.php>

Ethernet controller

The ENC28J60 is a stand-alone Ethernet controller with an industry standard Serial Peripheral Interface (SPI™). It is designed to serve as an Ethernet network interface for any controller equipped with SPI. The ENC28J60 meets all of the IEEE 802.3 specifications. It incorporates a number of packet filtering schemes to limit incoming packets. It also provides an internal DMA module for fast data throughput and hardware assisted IP checksum calculations. Communication with the host controller is implemented via two interrupt pins and the SPI, with data rates of up to 10 Mb/s. Two dedicated pins are used for LED link and network activity indication. Detailed information is available from Microchip web site:

http://www.microchip.com/stellent/idcplg?IdcService=SS_GET_PAGE&nodeId=1335&dDocName=en022889

EEPROM

The AD45DB081 is serial interface Flash memory ideally suited for a wide variety of digital voice, image, program code and data storage application. Its 8 650 752 bits of memory are organized as 4096 pages of 264 bytes each. In addition to the main memory, the AD45DB081 also contains two SRAM data buffers of 264 bytes each. The buffers allow receiving the data while a page in main memory is being programmed, as well as writing continuous data stream.

In-System Programming

LPC2138 micro-controller can be re-programmed remotely over the RS-232 interface. There is a second micro-controller on the board (ATtiny2313) for this purpose. The in-circuit programming feature simplifies program development on the board since downloading programs from a host PC takes only few seconds. User programs can also be debugged through the serial port.

ARM7 Development System based on Micro-IDE Integrated Development Environment from BiPOM Electronics fully supports In-System Programming on the MINI-MAX/ARM using the serial port.

The Mini-Max/ARM board provides the second interface (JTAG, J9) that can be used to program Flash memory. The LPC2131/2132/2138 CPU's support emulation and debugging via a JTAG serial port. A trace port allows tracing program execution.

Keypad connector

Keypad connector can be used to scan various types of keypads, such as 3 by 5 or 4 by 4. Keypad connector contains 5 Volt power and ground lines and the 8 port lines of the micro-controller. The lines can also be used as general-purpose inputs/outputs.

Keypad Connector (J1)

Signal	Pin
P1.16 (KEY0)	1
P1.17 (KEY1)	2
P1.18 (KEY2)	3
P1.19 (KEY3)	4
P1.20 (KEY4)	5
P1.21 (KEY5)	6
P1.22 (KEY6)	7
P1.23 (KEY7)	8
Ground (GND)	9
VCC (+5V)	10

Table 1

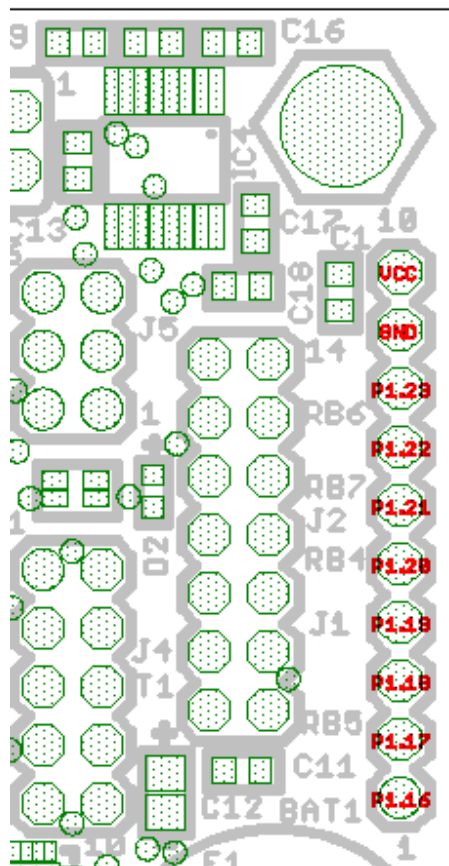

Figure 2

LCD Connector

LCD connector serves various types of character and graphic LCD modules.

Alternatively LCD port can be used as a 6-bit general purpose I/O. Contrast is a 10-bit analog PWM output to adjust the contrast of the LCD display under software control. Alternatively it can be used as a general purpose analog output. Contrast, PB4, PD0, PD1, PD2, and PD5 lines are driven by the 2nd AVR microcontroller by I2C interface.

LCD Connector (J2)

Signal	Pin	Pin	Signal
Ground (GND)	1	2	VCC (+5V)
Contrast (VEE)	3	4	P0.17 (CTRL)
PB4 (READ)	5	6	P0.18 (STROBE)
PD5 (LD4)	7	8	PD1 (LD5)
PD0 (LD6)	9	10	PD2 (LD7)
P0.19 (LD0)	11	12	P0.21(LD1)
P0.22 (LD2)	13	14	P0.23 (LD3)

Table 2

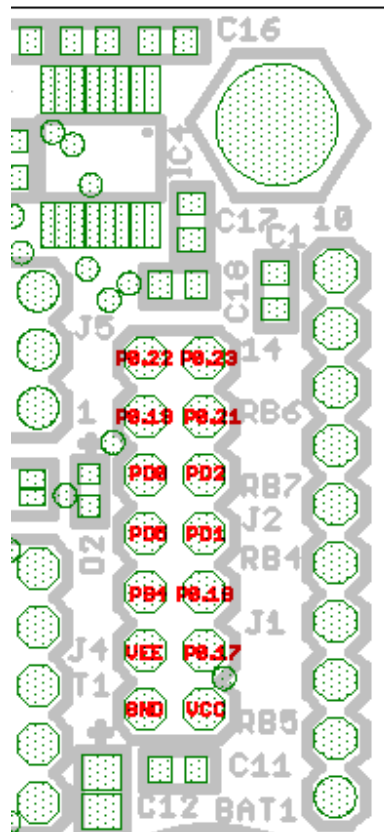

Figure 3

RS232 Serial Ports

Two RS232 serial ports are available on the MINI-MAX/ARM. IC4 converts micro-controller's RXD and TXD pins to/from RS232 levels. IC4 has an internal circuit that generates +/- 10 Volts for RS232 logic levels. First RS232 port is wired to a 10-pin header (J4). Second RS232 port is wired to a 6-pin header (J5).

There are two options. First option is two RS232 ports, each port has TXD and RXD lines only. Second option is a single RS232 interface with TXD, RXD, CTS and RTS signals on J4. For this purpose, 2 jumpers must be set between pins 5, 6 and 1, 2 of J5.

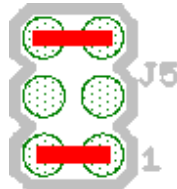

Figure 4

First serial port also serves downloading procedure to the MINI-MAX/ARM board. DSR is used by an external host to switch between BOOT and RUN modes.

1st RS232 Serial Port (J4)

Signal	Pin	Pin	Signal
NC (Not Connected)	1	2	DSR_0 (BOOT)
RXD_0 (RX0 input)	3	4	RTS_0* (RTS0 output)
TXD_0 (TX0 output)	5	6	CTS_0* (CTS0 input)
NC (Not Connected)	7	8	NC (Not Connected)
Ground (GND)	9	10	NC (Not Connected)

Table 3

Note. RTS_0/CTS_0 lines can be provided only installing 2 jumpers to J5.

2nd RS232 Serial Port (J5)

Signal	Pin	Pin	Signal
RXD_1 (RX input)	1	2	CTS_0* (CTS0 input)
Ground (GND)	3	4	NC (Not Connected)
TXD_1 (TX output)	5	6	RTS_0* (RTS0 output)

Table 4

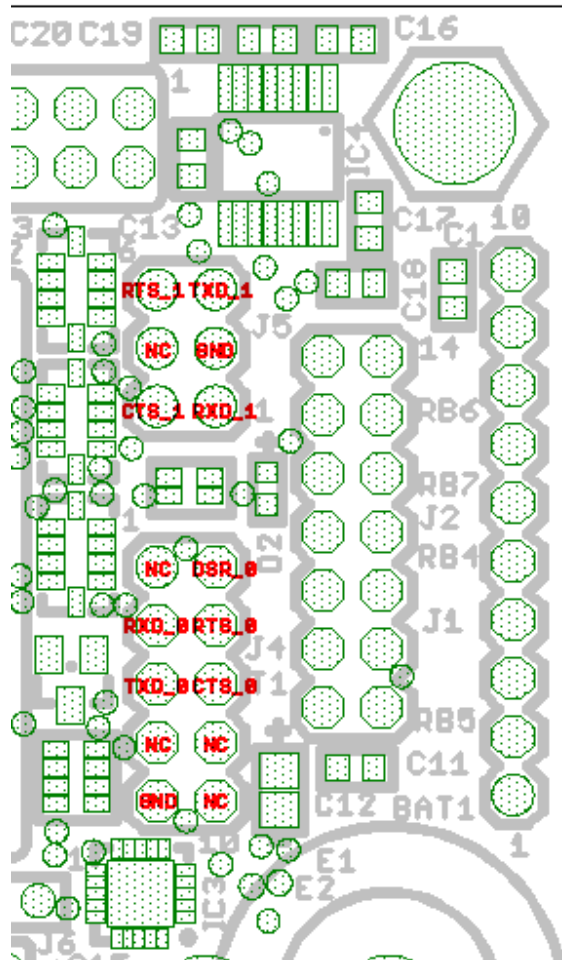

Figure 5

Expansion connector

Expansion connector can be used for interfacing to external circuitry, prototyping boards and peripheral boards. Expansion connector has 16 lines, which can be used as general purpose I/O. Some of these lines have special functions. MINI-MAX/ARM peripheral boards can be connected either as a piggy-back daughter-board on MINI-MAX/ARM using standoffs or can be placed up away from MINI-MAX/ARM using a 20-wire ribbon cable. Peripherals section lists the available expansion boards. Table 5 shows the pin assignments for the MINI-MAX/ARM Expansion connector.

Expansion connector (J3)

Signal	Pin	Pin	Signal
Ground (GND)	1	2	VCC (+5V)
Ground (GND)	3	4	VCC (+5V)
P0.3 (SDA)	5	6	P0.2 (SCL)
P0.14 (IO4)	7	8	P0.15 (IO5)
P0.12 (IO2)	9	10	P0.13 (IO3)
P0.10 (IO0)	11	12	P0.11 (IO1)
P0.6 (MOSI)	13	14	P1.24 (IO7)
P0.7 (CS)	15	16	P0.4 (SCK)
P0.5 (MISO)	17	18	P0.26 (IO6)
P0.0 (TXD0)	19	20	P0.1 (RXD0)

Table 5

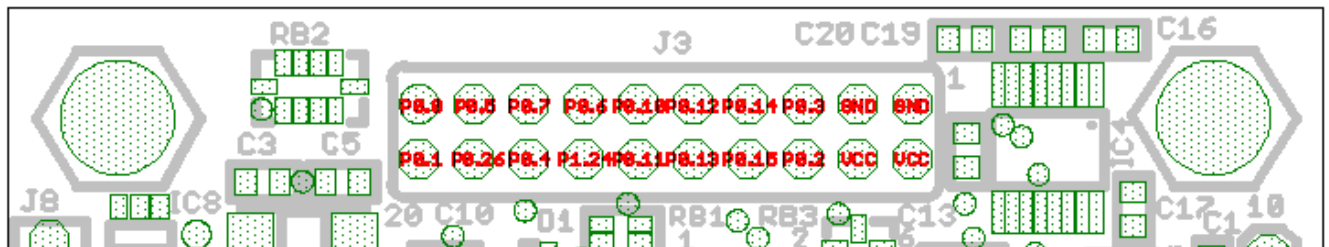

Figure 6

Analog interface

Analog terminal J8 serves for interfacing to various types of analog periphery, such as strain gages, pressure sensors, thermocouples etc. Five ADC inputs, analog reference VREF, analog power supply VAN and analog ground are wired to J8.

Analog terminals (J8)

Signal	Pin
P0.27 (AN0)	1
P0.28 (AN1)	2
Analog Ground (AGND)	3
P0.29 (AN2)	4
Analog Ground (AGND)	5
P0.30 (AN3)	6
3V Reference Voltage (VREF, output)	7
P0.25 (AN4)	8
Analog Ground (AGND)	9
3.3V Analog Power (VAN, output)	10

Table 6

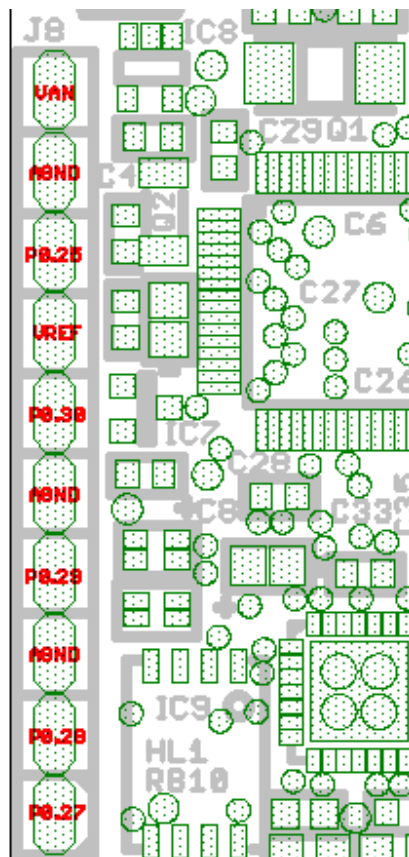

Figure 7

Real Time Clock

The Real Time Clock (RTC) is a set of counters for measuring time when system power is on, and when it is off. It uses little power in power down mode. LPC213x RTC provides Seconds, Minutes, Hours, Day of Month, Month, Year, Day of Week, and Day of Year. On the Mini-Max/ARM, the RTC can be clocked by an external 32.768 KHz oscillator, or by a programmable divider based on the peripheral clock. Also, the RTC is powered by its own power supply pin, V bat, which is connected to a 3.3V battery and to the 3.3V supply used by the rest of the device. If the board is on, the RTC is powered by the 3.3V power supply. If the board is off, the RTC is powered by the 3V battery automatically.

Power Supply Unit

MINI-MAX/ARM board comes with a 6VDC unregulated DC power supply. Other power supplies can also be used although this invalidates the warranty. External power supply should be able to supply 6 to 16 Volts DC at minimum 350mA current. The inner pin of the supply connector is positive and the outer ring is negative.

WARNING: Correct polarity should be observed when applying external DC supply to the power jack, otherwise MINI-MAX/ARM will be permanently damaged.

MINI-MAX/ARM has three on-board voltage regulators. IC5 provides +5V digital supply, IC6 is +3.3V for digital circuits and IC7 is +3.3V for analog circuits. The separate IC8 chip provides 3V ADC reference voltage.

CAUTION: Depending on the current requirements IC6 may dissipate enough heat to cause skin injury upon touch. Contact with this regulator should be avoided at all times, even after the power to circuit has been switched off.

4. Peripherals

A peripheral board can either be stacked on top of MINI-MAX/ARM using stand-offs or connected in a chain configuration using flat ribbon cable. Figure 8 shows how any peripheral board can be connected to a micro-computer board in a stacked fashion. Figure 9 shows the chain connection.

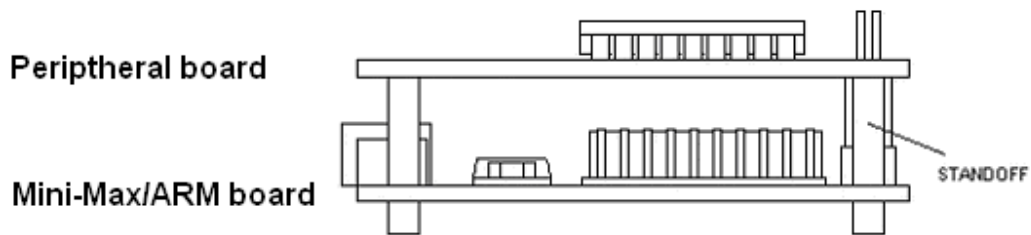

Figure 8

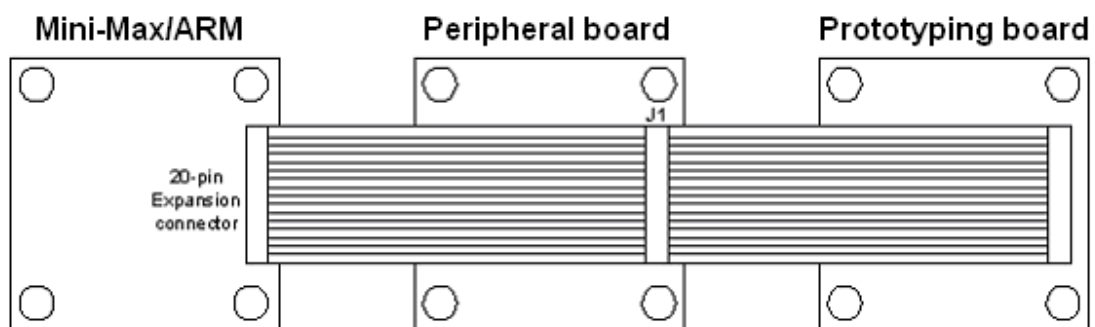

Figure 9

More details concerning BiPOM Peripheral boards are available from the link below:

http://www.bipom.com/periph_boards.php

5. Software

Please visit <http://www.bipom.com/armdevfaq.php> and read FAQ's.

Please visit http://www.bipom.com/armdev_down.php and download

<http://www.bipom.com/devsys/arm7dev.zip> (ARM7 Development System).

6. Board Layout

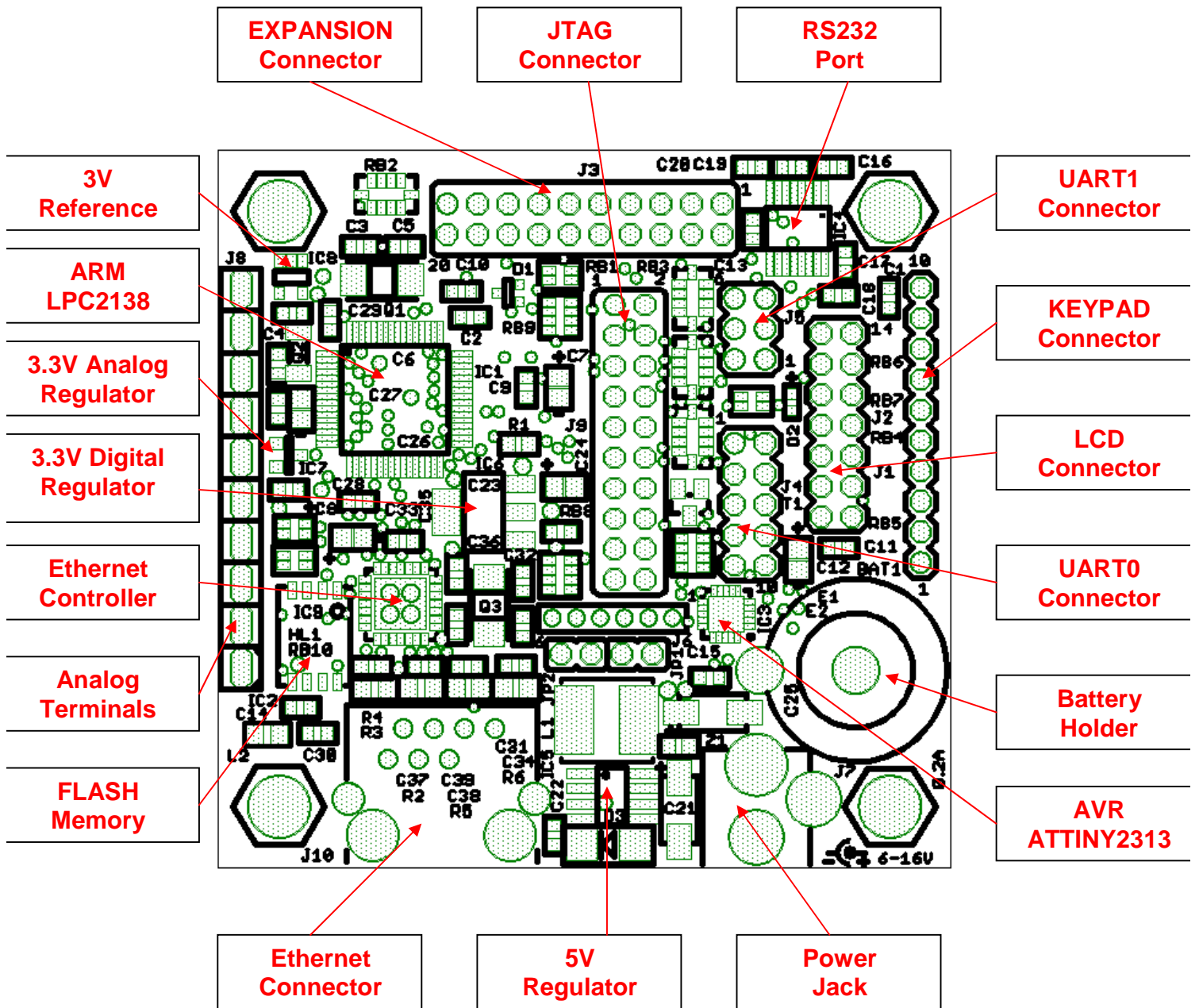
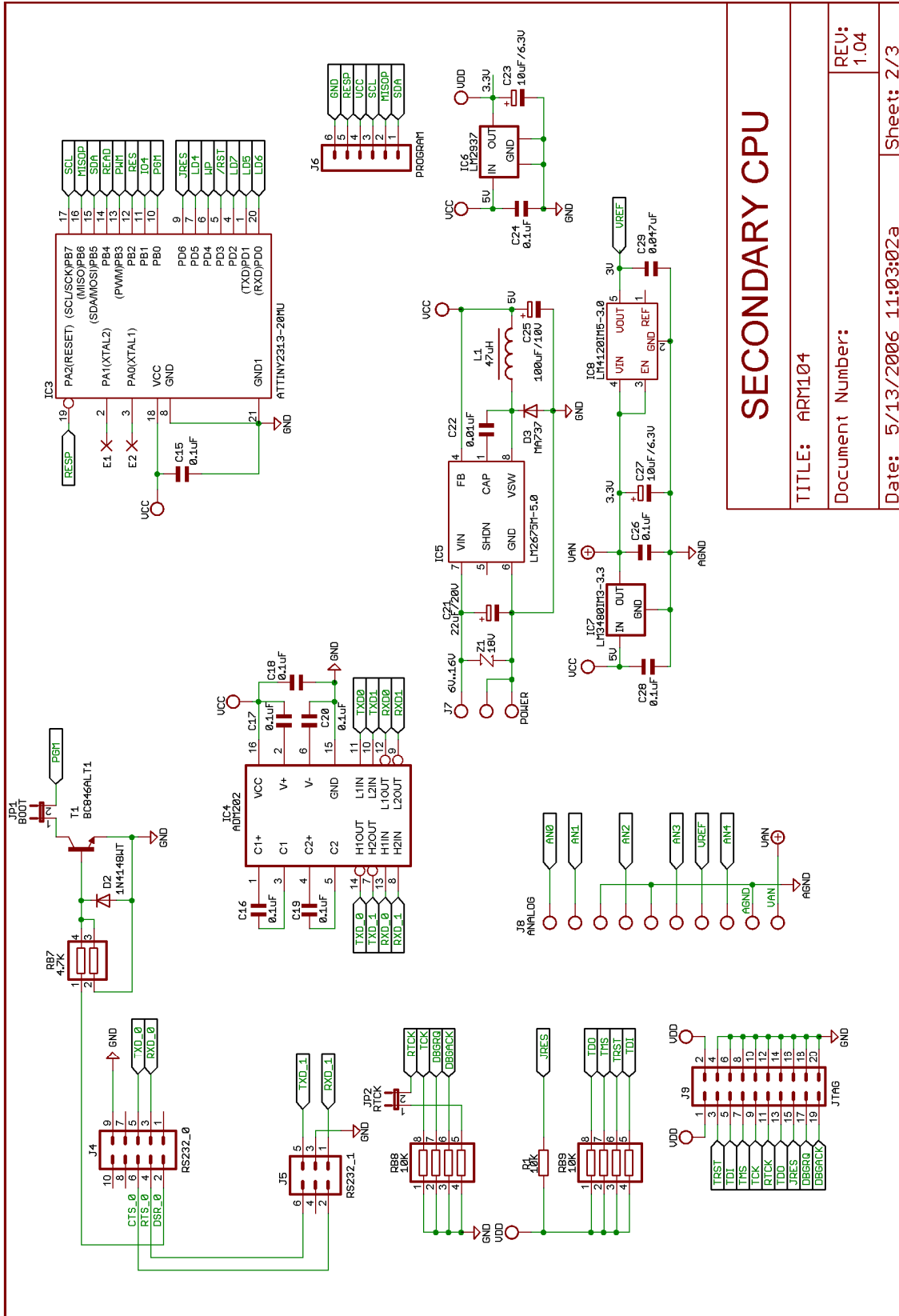

Figure 4

Note. Ethernet parts are not present in MINI-MAX/ARM-C.



SECONDARY CPU

TITLE: ARM104
 Document Number:
 Date: 5/13/2006 11:03:02a
 REV: 1.04
 Sheet: 2/3

Note. The parts shown on sheet 3/3, related to Ethernet feature, are not present in MINI-MAX/ARM-C.

