

ALTA® Wireless 0–20 mA Current Meters

General Description

The [ALTA® Wireless 0–20 mA Current Meter](#) is capable of measuring the current from transducers with a 4 to 20 mA DC output. Both 2-wire and 3-wire current loop transducers are supported.

Key Features

- ▶ Measures current up to 20 mA
- ▶ Resolution: 0.001 mA
- ▶ Accuracy:
 - ▶ Uncalibrated: 0.01 mA (typical)
 - ▶ Calibrated: 0.002 mA
- ▶ Measurement resistor: 73.2 Ohms
- ▶ Configurable thresholds for condition monitoring

Principles of Operation

The ALTA Wireless 0–20 mA Current Meter measures the DC loop current based on a user-configurable time interval or Heartbeat. On every Heartbeat, the sensor converts the analog current signal to a digital current measurement. This measurement is then sent to the gateway, making the data available in iMonnit or another approved data service.

The ALTA 0–20 mA Current Meter can be calibrated for improved accuracy. Also, remember to remove any active current from the measurement leads when replacing batteries or performing other maintenance.

Example Applications

- ▶ Current transducers
- ▶ pH sensors
- ▶ Dissolved oxygen sensors
- ▶ Pressure sensors
- ▶ Magnetic flow sensors
- ▶ [Additional Applications](#)

Features of Monnit ALTA Sensors

- Wireless range of 2,000+ feet through 18+ walls¹
- Frequency-Hopping Spread Spectrum (FHSS)
- Best-in-class interference immunity
- Best-in-class power management for longer battery life²
- Encrypt-RF® Security (Diffie-Hellman Key Exchange + Advanced Encryption Standard (AES)-128 Cipher Block Chaining (CBC) for sensor data messages)
- Sensor logs 2000 to 4000 readings if the gateway connection is lost (non-volatile flash, persists through power cycling):
 - 10-minute Heartbeats = ~ 22 days
 - 2-hour Heartbeats = ~ 266 days
- Automatic over-the-air updates to sensor firmware (future-proof)
- Free iMonnit Basic Online Wireless Sensor Monitoring and Notification System to configure sensors, view data, and send alerts via SMS text, email, and voice call

¹ Actual range may vary depending on the environment and gateway.

² Battery life is determined by the sensor reporting frequency and other variables. Other power options are also available.

Wireless Range Comparison

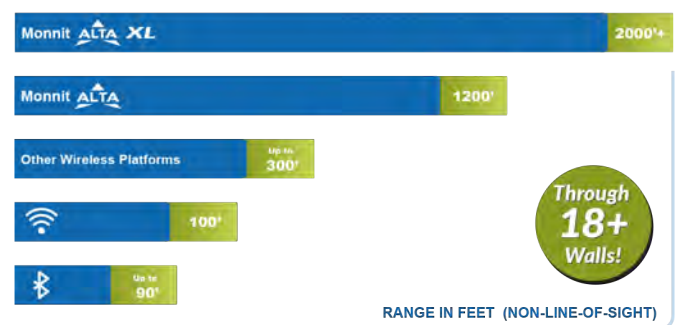

Technical Specification | ALTA® Wireless 0-20 mA Current Meters

Current Meter	Measurement Range	0–20 mA ¹
	Sensor resolution	0.001 mA (15-bit single ended)
	Accuracy	Uncalibrated: 0.01 mA (typical), 0.03 mA (worst case) Calibrated: 0.002 mA
	Conversion time	1.02 ms
	Load resistance	73.2
	Load Voltage (@ 20mA)	1.46 V
Lead	Cable length	Standard: 0.3 m (1 ft)
	Wire count	2-conductor (red/black)
	Wire gauge	22 AWG
	Conductor material	Stranded Copper 7/30
	Insulation	PVC, 0.010"
	Shield	No
	Jacket	PVC (black)
	Overall Diameter	4.2 mm (0.164")
	Ratings / Approvals	NEC (UL) Type CM, UL AWM Style 2464, CSA AWM FT4, RoHS/Reach Compliant
	Temperature Rating	-20°C to 85°C (-4°F to 185°F) ²
ALTA Wireless	Data logging	Sensor logs 2000 to 4000 readings if gateway connection is lost (non-volatile flash, persists through power cycling): 10-minute Heartbeats = ~22 days - 2-hour Heartbeats = ~266 days
	Wireless protocol	ALTA Proprietary Frequency-Hopping Spread Spectrum (FHSS)
	Wireless transmission power (EIRP)	50 mW (900MHz), 25 mW (868 MHz), 10 mW (433 MHz)
	Wireless range	2,000+ ft. through 18+ walls with the ALTA XL® Gateway
Security	Encrypt-RF® (256-bit key exchange and AES-128 CTR)	
General	Battery voltage range	2.0 to 3.8 VDC
	Operating altitude (non-pressurized)	-15.2 to 1,982 m (-50 to 6,500 ft) ³
	Storage altitude (non-pressurized environments)	-15.2 to 3,048 m (-50 to 10,000 ft) ³
	Operating humidity	5 to 85% RH (non-condensing)
	Certifications	900 MHz sensors: FCC ID: ZTL-G2SC1 and IC: 9794A-G2SC1 . 868 and 433 MHz sensors tested and comply with: EN 55032: 2015/A11:2020; EN 55035:2017/A11:2020; ETSI EN 300 220 V3.2.1 (2018-06); ETSI EN 301 489-3 V2.2.0. (2021-11); and ETSI EN 303 645 . All sensors tested and comply with: EN 61010-1 and EN 60950 and meet RoHS 2015/863 and REACH 224 (June 2022) , according to IEC 63000:2016/AMD1:2022 .



1. If application exceeds 20 mA the sensor will return a maximum reading of 20 mA. If current applied to measurement port exceeds 30 mA, circuit protection and conditioning is required.
2. Temperatures colder than the rating are acceptable if the cable is not moving or vibrating.
3. Operating and storage altitude without DC power supply is -30.48 to 9144 m (-100 to 30000 ft).

Selecting a Compatible Transducer

When selecting a transducer, the following specifications are important to guarantee correct and accurate data is recorded.

- ▶ Signal output: DC 4–20 mA current
- ▶ Load resistance: 73.2 ohms or greater permitted

Most transducers expect to support load resistances of 250-1000 ohms. At 73 ohms, the ALTA 0–20 mA Sensors can be installed in series with other measurement, display, and reporting equipment in the same measurement loop.

Proper Installation

Please review the wiring diagrams (to the right) to ensure proper setup and to avoid wireless meter damage.

2-Wire Loop Integration

This approach uses a single loop. The positive terminal of the DC power source is connected to a current transducer. The transducer produces a milliamp (mA) signal and is connected to the **RED** wire of the ALTA Sensor. The **BLACK** wire of the ALTA Sensor is connected to the negative terminal of the DC power source.

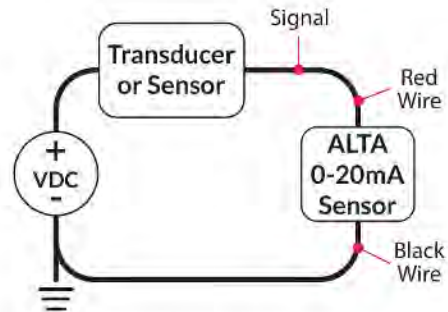

2 Wire Sensor Integration

3-Wire Loop Integration

This approach uses two loops:

1. A power loop
2. A measurement loop

In the power loop, the positive terminal of the DC power source is connected to a current transducer's positive terminal and the transducer's negative terminal is connected to the negative terminal of the DC power source. In the measurement loop, the transducer's milliamp signal output is connected to the **RED** wire of the ALTA Sensor. The **BLACK** wire of the ALTA Sensor is connected back to the negative terminal of the DC power source.

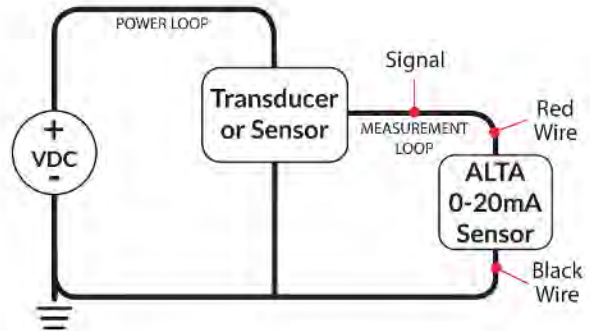

3 Wire Sensor Integration

Improper Installation

The ALTA 0–20 mA Sensor cannot survive more than 4VDC directly across the sensor. For example, if the ALTA 0–20 mA Sensor is attached directly to the DC power supply that is intended to power the transducer directly, the sensor will be irreparably damaged.

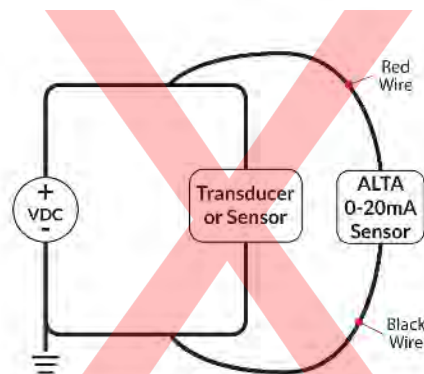

Incorrect Sensor Integration

The sensor reports the 0–20 mA (milliamp) loop measurement.

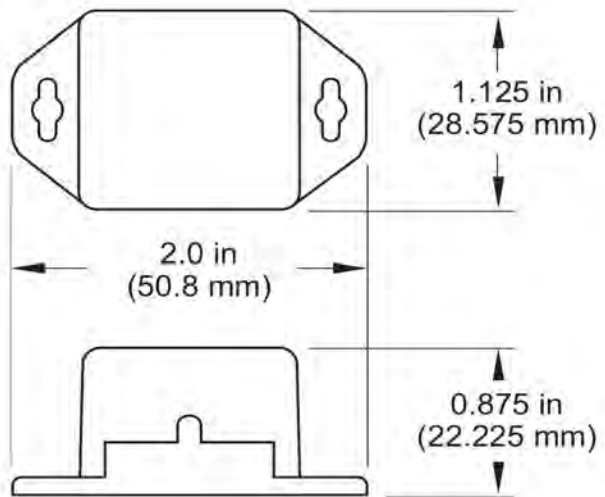

PinchPower™ Enclosures

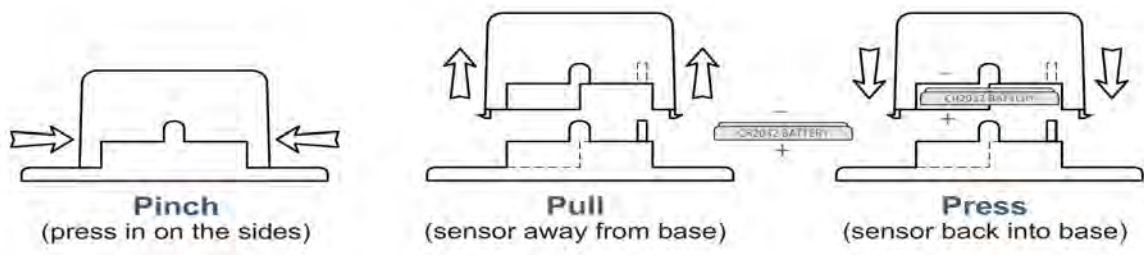

Technical Specifications | ALTA® Commercial 0-20 mA Current Meter

Battery ¹	1x 3.0 V CR2032 Button Cell, 100 mAh
Battery Life	2+ years expected
Operating temperature range (board circuitry and coin cell) ²	-7°C to 60°C (20°F to 140°F)
Wireless antenna type	1/4-wave, 20 gauge wire whip, 3.5" (900/868MHz), 7" (433MHz)
Weight	0.7 oz. (19.8 g)

1. Hardware cannot withstand negative voltage. Please take care when inserting and removing battery.
 2. Operating below 0°C (-32°F) degrees will reduce battery life.

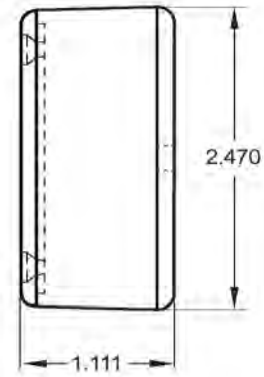
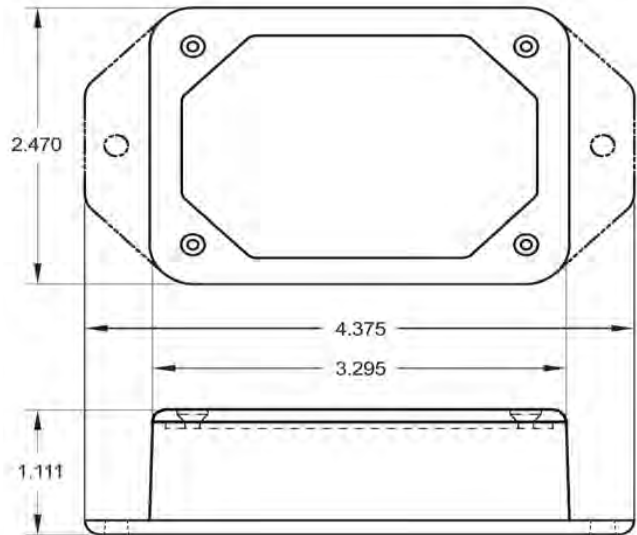

Technical Specifications ALTA® Enterprise 0-20 mA Current Meter	
Battery ¹	2x 1.5 V AA Alkaline, 1500 mAh, (standard) 2x 1.5 V AA Lithium, 3000 mAh, (optional)
Battery Life	10+ years expected
External line-power option ²	Input voltage: 5.0-12.0 V Power jack: 2.1 x 5.5 mm barrel, center positive
Operating temperature range (board circuitry and batteries) ³	-18°C to 55°C (0°F to 130°F) - AA Alkaline Batteries -25°C to 60°C (-13°F to 140°F) - AA Lithium L91 Batteries 0°C to 40°C (32°F to 104°F) - US 5V Power Supply 10°C to 40°C (50°F to 104°F) - International 5V Power Supply
Wireless antenna type	1/4-wave, 20 gauge wire whip, 3.5" (900/868MHz), 7" (433MHz)
Weight	3.7 oz. (105 g)

1. Hardware cannot withstand negative voltage. Please take care when inserting and removing batteries.
2. Batteries will provide backup power in the case the external power is removed.
3. Operating below 0°C (-32°F) degrees will reduce battery life.

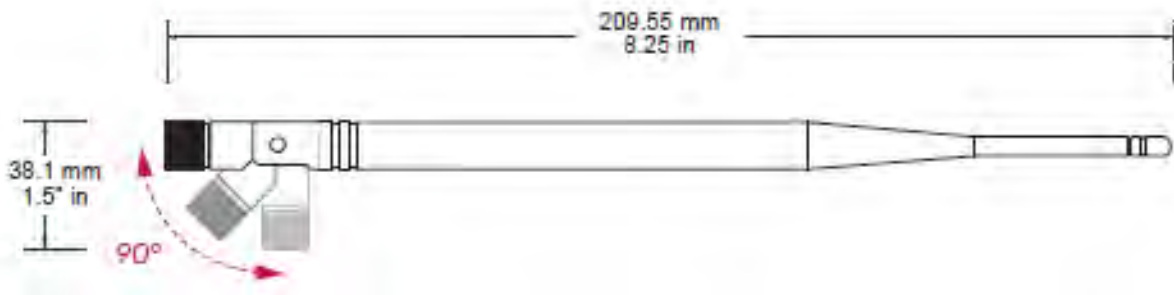
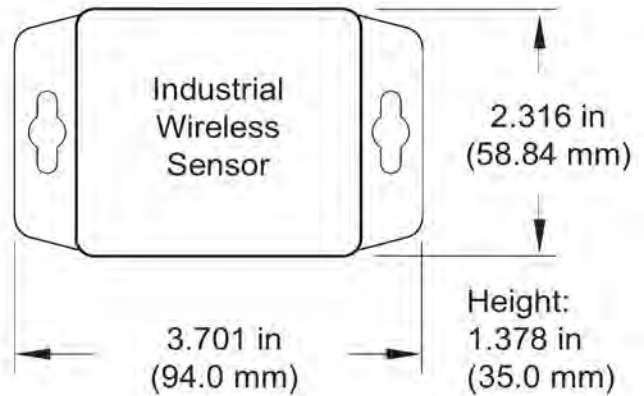

Technical Specifications | ALTA® Industrial 0-20 mA Current Meter

Battery	1x 3.6 V AA Lithium Thionyl Chloride, 1500 mAh, pre-installed
Battery Life	10+ years expected
Operating temperature range (non-leaded measurement range) ¹	-40°C to 85°C (-40°F to 185°F)
Wireless antenna type	1/2-wave waterproof dipole with RP-SMA connector and swivel neck; dBi of 3.0 (900/868MHz) or 2.5 (433 MHz); length of 8.27" (210mm) (900/868MHz) or 7.68" (195mm) (433 MHz); diameter at thickest point of 0.55" (14mm)
Weight	4.7 oz. (133 g)
Enclosure rating	IP-65 (dust-proof and waterproof but not submersible) NEMA 1, 2, 4, 4x, 12, and 13 rated, sealed, and weatherproof UL Listed to UL508-4x specifications (File E194432)

1. Operating below 0°C (-32°F) degrees will reduce battery life.

Commercial-Grade Sensors

Monnit commercial-grade sensors are designed for applications in ordinary environments (normal room temperature, humidity, and atmospheric pressure). Do not use these sensors under the following conditions, as these factors can deteriorate the product characteristics and cause failures and burnout.

- Corrosive gas or deoxidizing gas: chlorine gas, hydrogen sulfide gas, ammonia gas, sulfuric acid gas, nitric oxide gas, etc.
- Volatile or flammable gas
- Dusty conditions
- Low-pressure or high-pressure environments
- Wet or excessively humid locations
- Places with salt water, oils, chemical liquids, or organic solvents
- Where there are excessively strong vibrations
- Other places where similar hazardous conditions exist

Use these products within the specified temperature range. Higher temperatures may cause deterioration of the characteristics or the material quality.

Industrial-Grade Sensors | Type 1, 2, 4, 4X, 12, and 13 NEMA-Rated Enclosure

Monnit's industrial sensors are enclosed in reliable, weatherproof NEMA-rated enclosures. Our NEMA-rated enclosures are constructed for indoor and outdoor use and protect the sensor circuitry against the ingress of solid foreign objects like dust and the damaging effects of water.

- Safe from falling dirt
- Protects against wind-blown dust
- Protects against rain, sleet, snow, splashing water, and hose-directed water
- Increased level of corrosion resistance
- Will remain undamaged by ice formation on the enclosure



Monnit Corporation

3400 South West Temple • Salt Lake City, UT 84115 • 801-561-5555
www.monnit.com