

# Monnit

## Wireless 500 VAC/VDC Voltage Meter

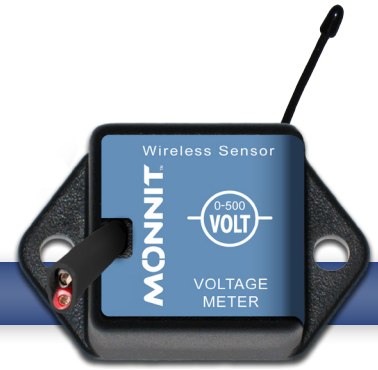

### Technical Overview

#### General Description

The Wireless 500 VAC/VDC Voltage Meter is an analog measuring device that reports the measured voltage on user specified intervals. The sensor has three operating modes, in which you can obtain the voltage measurement in VACrms (root mean squared), the peak voltage, or the DC voltage. The modes can be set by the user; the default mode measures VACrms.

#### Features

- Wireless interface for measuring voltage.
- Measures voltage up to 500 VAC/VDC.
- Free iMonnit basic online wireless sensor monitoring and notification system to configure sensors, view data and set alerts via SMS text and email.

#### Principle of Operation:

By connecting the leads on the Monnit Wireless 500 VAC/VDC Voltage Meter to the positive and ground terminals of another device, battery or sensor, it can measure the voltage and send data to the iMonnit Online Sensor Monitoring and Notification System. The data is stored in the online system and can be reviewed and exported as a data sheet or graph. Notifications can be set up through the online system to alert the user when certain thresholds have been met or exceeded.

#### Power Options

Sensors are powered by a replaceable 3.0 V coin cell battery. Optional AA battery powered sensors are available. The AA version of these sensors are larger in size (3" [L] x 2.1" [W] x 1.2" [H] ) and include two long-life AA batteries.

It is recommended that unless you are using the AA battery solution, you set heartbeat to no faster than one hour to preserve battery life.

#### Monnit Sensor Core Specifications

- Power: Replaceable 3.0 V coin cell battery
- Communication: RF 900, 920, 868 and 433 MHz
- Dimensions: 1.775" x 1.040" x 0.785"
- Antenna: 4" wire antenna
- Operating Temperature: -7° to 60°C (20° to 140°F)
- Device Range: 250 - 300 ft. non-line-of-sight\*
- Battery Life: At 1 hour heartbeat setting, coin cell battery will last ~ 1-2 years.\*\*

- \* Actual range may vary depending on environment.  
\*\* Battery life is determined by sensor reporting frequency and other variables.

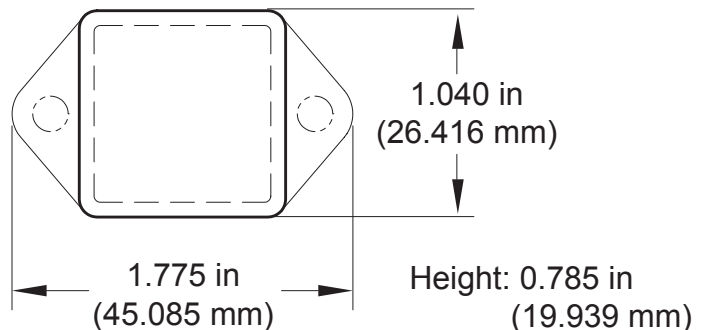

#### Example Interfacing

- Power Lines
- Machinery
- Electrical Motors
- Generators
- And many more...

**The Leader in Low Cost Wireless Sensors**

Technical Specifications	
Supply Voltage	2.0 - 3.6 VDC *
Current Consumption	0.7 $\mu$ A (sleep mode) 2 mA (radio idle/off mode) 2 mA (measurement mode) 25 mA (radio RX mode) 35 mA (radio TX mode)
Operating Temperature Range (Board Circuitry and Coin Cell)	-7°C to +60°C ( 20°F to +140°F )**
Optimal Battery Temperature Range (Coin Cell)	+10°C to +50°C ( +50°F to +122°F )
Sensor Resolution	11 bit (single ended)
Conversion Time	228 $\mu$ s
Supported Operation Modes ***	VACrms (root mean squared) Peak Voltage DC Voltage
Full Scale Voltage	0 - 500 VAC/VDC ****
Maximum Input Voltage	600 VAC/VDC ****
Certifications	 900 MHz product; FCC ID: ZTL- RFSC1 and IC: 9794A-RFSC1. 920 MHz product; ARIB STD-T108 R210-103733. 868 and 433 MHz product tested and found to comply with: CISPR 22:2008-09 / EN 55022:2010 - Class B and ETSI EN 300 220-2 V2.4.1 (2012-05).

\* Hardware can not withstand negative voltage. Please take care when connecting a power device.

\*\* At temperatures above 100°C, it is possible for the board circuitry to lose programmed memory.

\*\*\* Operation mode must be specified at time of purchase.

\*\*\*\* If application exceeds 500 VAC/VDC the sensor will return a maximum reading of 500 V.

## Proper Installation:

If the sensor is not connected to the power source properly, it will appear that the sensor is broken. Please follow this wiring diagram to ensure proper performance and detection.

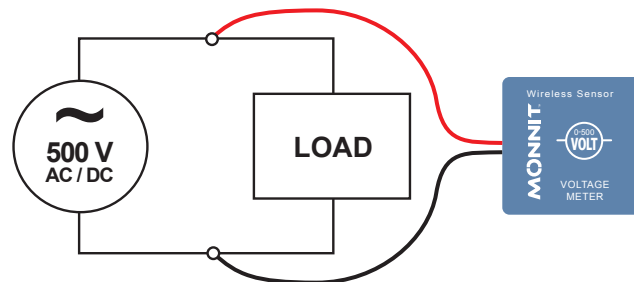

## Caution/Notice:

This product is designed for application in an ordinary environment (normal room temperature, humidity and atmospheric pressure). Do not use this sensor under the following conditions as these factors can deteriorate the product characteristics and cause failures and burn-out.; corrosive gas or deoxidizing gas - chlorine gas, hydrogen sulfide gas, ammonia gas, sulfuric acid gas, nitric oxides gas, etc.), volatile or flammable gas, dusty conditions, under low or high pressure, wet or excessively humid locations, places with salt water, oils chemical liquids or organic solvents, where there are excessively strong vibrations, other places where similar hazardous conditions exist.

Use this product within the specified temperature range. Higher temperature may cause deterioration of the characteristics or the material quality of this product.

For more information about our products or to place an order, please contact our sales department at 801-561-5555.

Visit us on the web at [www.monnit.com](http://www.monnit.com).

**MONNIT**<sup>®</sup>

Monnit Corporation  
4403 South 500 West  
Murray, UT 84123  
801-561-5555  
[www.monnit.com](http://www.monnit.com)