

Monnit

Wireless Pressure Sensor



Technical Overview

General Description

The Monnit wireless pressure sensor measures pressure from a 5 volt pressure transducer and transmits the pressure measurement to iMonnit. This solution combines a standard pressure transducer interfaced to a Monnit wireless radio.

Features

- Measure pressure with 50 or 300 PSIG transducers (others available upon request).
- Measure non-caustic liquid or vapor pressures.
- Pressure transducer is NEMA 4X (IP66), CE rated.
- Free iMonnit basic online wireless sensor monitoring and notification system to configure sensors, view data and set alerts via SMS text and email.

Principle of Operation:

By connecting the Monnit wireless pressure sensor to a pressurized gas, liquid or vapor supply line, it can measure the pressure within the line and send data to the iMonnit Online Sensor Monitoring and Notification System. The data is stored in the online system and can be reviewed and exported as a data sheet or graph. User customization allows you to set notifications and alerts from the system so you can know immediately if pressure is above or below an optimal range.

Example Interfacing

- Compressors/Compressed Air Lines
- Water Supply Lines
- Pumping Systems
- Irrigations System Pressure
- Industrial Process Monitoring
- Trash Compaction Equipment

Monnit Sensor Core Specifications

- Power: Replaceable AA batteries
- Communication: RF 900, 868 and 433 MHz
- Dimensions: 4.375" x 2.470" x 1.111"
- Antenna: 4" wire antenna
- Operating Temperature: -7° to 60°C (20° to 140°F)
- Device Range: 250 - 300 ft. non-line-of-sight*
- Battery Life: At 1 hour heartbeat setting, AA batteries will last more than 4 years.**

* Actual range may vary depending on environment.

** Battery life is determined by sensor reporting frequency and other variables.

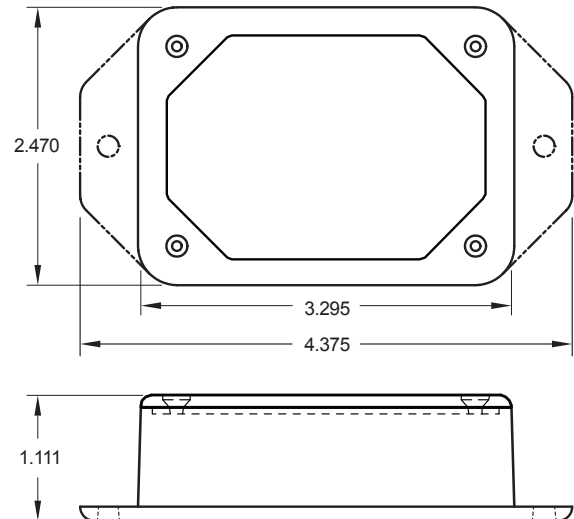

The Leader in Low Cost Wireless Sensors

Monnit Wireless Sensor Technical Specifications

Supply Voltage	2.0 - 3.6 VDC *
Current Consumption	0.7 μ A (sleep mode) 2 mA (radio idle/off mode) 2 mA (measurement mode) 25 mA (radio RX mode) 35 mA (radio TX mode)
Operating Temperature Range**	Using Alkaline AA Batteries: -18°C to +55°C (0°F to +130°F) Using Lithium AA Batteries: -40°C to +85°C (-40°F to +185°F)
Certifications	 900 MHz product; FCC ID: ZTL- RFSC1 and IC: 9794A-RFSC1. 868 and 433 MHz product tested and found to comply with: CISPR 22:2008-09 / EN 55022:2010 - Class B and ETSI EN 300 220-2 V2.4.1 (2012-05).

Pressure Transducer Technical Specifications

Operating Temperature	0 to 175°F (-18 to 79°C).
Thermal Effect on Reading	\pm 0.02% FS/°F. (includes zero and span).
Media	Gas, Liquid or Vapor
Response Time	50 msec.
Stability	1.0% FS/year (Typ.).
Wire Length	1 Meter shielded cable (between gauge and wireless unit)
Accuracy	0.25% FS; 0.20% RSS; Absolute Ranges: 0.5% FS; 0.35% RSS. (Includes linearity, hysteresis, and repeatability).
Max Voltage Input	5.5 V
Voltage Measurement Range	0 - 5.2 V ***
Voltage Measurement Resolution	~3 mV
Voltage Measurement Accuracy	\pm 3% FS
Pressure Measurement Accuracy	\pm 3% FS
User Calibrated Pressure Accuracy	+/- 1% FS ****
Pressure Transducer(s)	50 or 300 PSIG (Others available upon request)

* Hardware can not withstand negative voltage. Please take care when connecting a power device.

** At temperatures above 100°C, it is possible for the board circuitry to lose programmed memory.

*** The sensor is capable of measuring above 5 volts but may not meet the specified accuracy above this value.

**** For best results first zero the sensor then calibrate at greater than 20% maximum pressure of the transducer.



Monnit Corporation
7304 South Cottonwood
Suite #204
Midvale, Utah 84047
801-561-5555
www.monnit.com

For more information about our products or to place an order, please contact our sales department at 801-561-5555.

Visit us on the web at www.monnit.com.