

MONNITLINK™

USB Gateway

Technical Overview



General Description

The MonnitLink™ USB gateway allows your Monnit Wireless Sensors to communicate with the iMonnit™ online wireless sensor monitoring and notification system or Monnit Express™ standalone PC software. Simply install the USB driver and plug the device into an available USB port on a Microsoft Windows PC.

If the PC has an active internet connection and you wish to use it with the iMonnit online software, install the Monnit Gateway application to pass sensor data to the online system. If you wish to use your wireless sensors locally (collect and store sensor data on your PC), install the Monnit Express standalone software and all sensor data will be stored within the software's database. The Monnit Express software allows you to export sensor data in a .csv format spreadsheet, and is also capable of sending SMS text and email alerts if the host computer has an active Internet connection,

With the online iMonnit software, you can easily configure your network, view collected sensor data and set alarms through SMS or e-mail, all from any web enabled browser. The system allows for complete configuration and customization at a sensor, local network, or client wide level.

Monnit's USB gateway is specifically designed to respond to the increasing market need for global technology that accommodates a variety of vertical M2M application segments and remote wireless sensor management solutions.

The gateway is available in global frequencies of 900, 868 or 433MHz. Enjoy reliable, low cost, wireless monitoring of your facilities or specific applications, with Monnit wireless sensor networks.

MonnitLink™ USB Gateway Features

- Supports multiple RF technologies including 900, 868 and 433MHz sensor solutions.
- Uses host PC for power.
- Can be used with both iMonnit Online Software or Monnit Express Standalone PC Software.
- Programmable heart-beat control.
- Supports up to 100 wireless sensors per USB.
- Windows 8, 7, and Vista compatible.

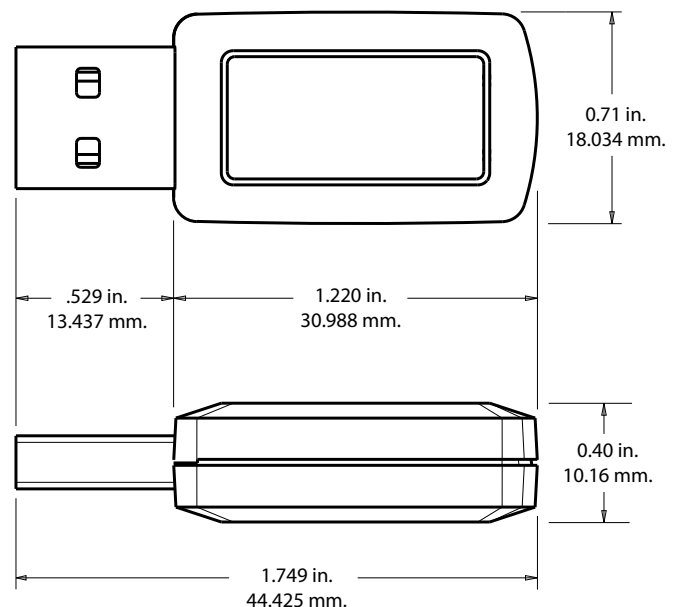

Applications

- Commercial Facilities Monitoring
- Industrial Facilities Monitoring
- Property Management
- Data Center Monitoring
- Convenience Store Monitoring

The Leader in Low Cost Wireless Sensors

Monnit USB Gateway Specifications

USB

Type:	USB 2.0 Full Speed Bus Standard
Display Name:	Monnit USB Radio Gateway
Display Type:	MonnitApnClass
Version:	1.0.3.0
Software Compatible Platforms:	Microsoft Windows 8, Windows 7 or Windows Vista required. (Windows XP and older are not supported.)
Bus Reported Device Description:	M+ LINK
Memory Capacity:	40,000 messages

Power

Power	Powered through USB output of PC
Maximum Power Required:	50 mA

Mechanical

Enclosure	ABS plastic
Dimensions	1.75 x 0.71 x 0.40 Inches
Weight	0.36 ounces

Environmental

Operating Temperature	-40 to +85 °C
Certifications:	FC CE  Industry Canada 900 MHz product; FCC ID: ZTL- RFUSB1 and IC: 9794A-RFUSB1. 868 and 433 MHz product tested and found to comply with: CISPR 22:2008-09 / EN 55022:2010 - Class B and ETSI EN 300 220-2 V2.4.1 (2012-05).



For more information about our products or to place an order, please contact our sales department at 801-561-5555.

Visit us on the web at www.monnit.com.

Monnit Corporation
4403 South 500 West
Murray, UT 84123
801-561-5555
www.monnit.com