

THERMOCOUPLE-4 Peripheral Board

Technical Manual

Document Revision: 1.02

Date: 28 January, 2010



BiPOM Electronics, Inc.

16301 Blue Ridge Road, Missouri City, Texas 77489
Telephone: 1-713-283-9970 Fax: 1-281-416-2806
E-mail: info@bipom.com
Web: www.bipom.com

© 2004-2010 by BiPOM Electronics. All rights reserved.

THERMOCOUPLE-4 board. No part of this work may be reproduced in any manner without written permission of BiPOM Electronics.

All trademarked names in this manual are the property of respective owners.

WARRANTY:

BiPOM Electronics warrants THERMOCOUPLE-4 board for period of 1 year. If the board becomes defective during this period, BiPOM will at its option, replaced or repair the board(s). This warranty is voided if the product is subjected to physical abuse or operated outside state electrical limits. BiPOM Electronics disclaims to any external devices connected to boards of THERMOCOUPLE-4 board. BiPOM Electronics disclaims all warranties express or implied warranties of merchantability and fitness for a particular purpose. In no event shall BiPOM Electronics be liable for any indirect, special, incidental or consequential damages in connection with or arising from the use of this product. BiPOM Electronics' liability is limited to the purchase of this product.

TABLE OF CONTENTS

1. INTRODUCTION	3
2. OVERVIEW	3
3. SPECIFICATIONS	4
4. FUNCTIONAL BLOCKS	5
5. BOARD LAYOUT	7
6. SCHEMATICS	8

1. Introduction

A thermocouple is a sensor for measuring temperature. It consists of two dissimilar metals, joined together at one end. When the junction of two metals is heated or cooled some voltage is produced that can be correlated back to the temperature. A thermocouple is available in different combinations of metals or calibrations. The four most common calibrations are J, K, T and E. There are high temperature calibrations R, S, C and GB. Each calibration has a different temperature range and environment.

Typically, when a thermocouple is connected to any equipment, two unwanted thermocouple junctions are formed where the iron and constantan connect to ordinary copper wire (see figure 1). These junctions are commonly called the cold junction because a common practice is to immerse the T2 junction in 0°C ice/water slurry to make T2 independent of room temperature variations. Thermocouple tables are based on a cold junction temperature of 0°C.

The BiPOM THERMOCOUPLE-4 Board provides LT1025 Linear Technology IC which adds a temperature dependent voltage ($V_{comp.}=f(T)$) such that the voltage sum is the same as if T2 junctions were at a constant 0°C.

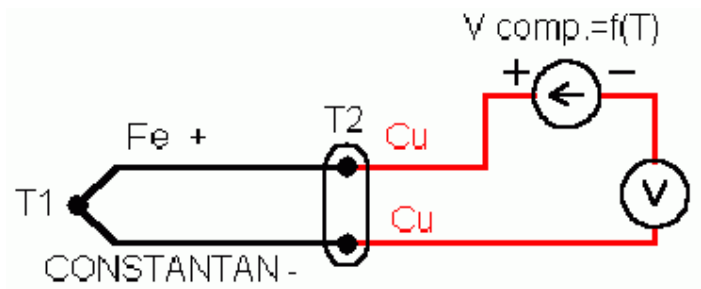

Figure 1.

2. Overview

THERMOCOUPLE-4 Board is intended to a wide range temperature measurement using various types of thermocouples. It has four independent channels. Each channel consists of LT1025 cold junction compensator IC and precision thermocouple voltage amplifier.

There are two ways to connect THERMOCOUPLE-4 board to other BiPOM boards:

- Directly to MINI-MAX-51F single board computer board, through analog connector.
- To a DAQ-2543 Analog peripheral board, through analog connector. DAQ-2543 should be then connected to either of BiPOM single board computer, such as MINI-MAX/51-C, MINI-MAX/51-D, MINI-MAX/51-E, or MINI-MAX/PIC.

Up to two THERMOCOUPLE-4 boards can be connected at the same time.

3. Specifications

THERMOCOUPLE-4 and THERMOCOUPLE-4A are the same except THERMOCOUPLE-4A has cold junction compensation with less initial uncalibrated temperature error.

- Uncalibrated Cold junction compensation error: 0.5 °C for THERMOCOUPLE-4A
2 °C for THERMOCOUPLE-4
- Gain error: 0.2% of full scale
- 26-pin analog connector compatible with MINI-MAX/51-F and DAQ2543 boards.
- 8-pole screw terminal for four thermocouple connection.
- Single +5V power supply comes through analog connector.
- Dimensions are 2.35 X 2.40 inches (5.97 X 6.10 centimeters).
- Mounting holes of 0.138 inches (3.5 millimeters) are on four corners.
- 0° - 70° C operating, -40° - +85° C storage temperature range.
- 2-layer PCB for maximum reliability.

4. Functional blocks

THERMOCOUPLE-4 board has four similar channels. Block diagram of each channel is shown at Figure 2.

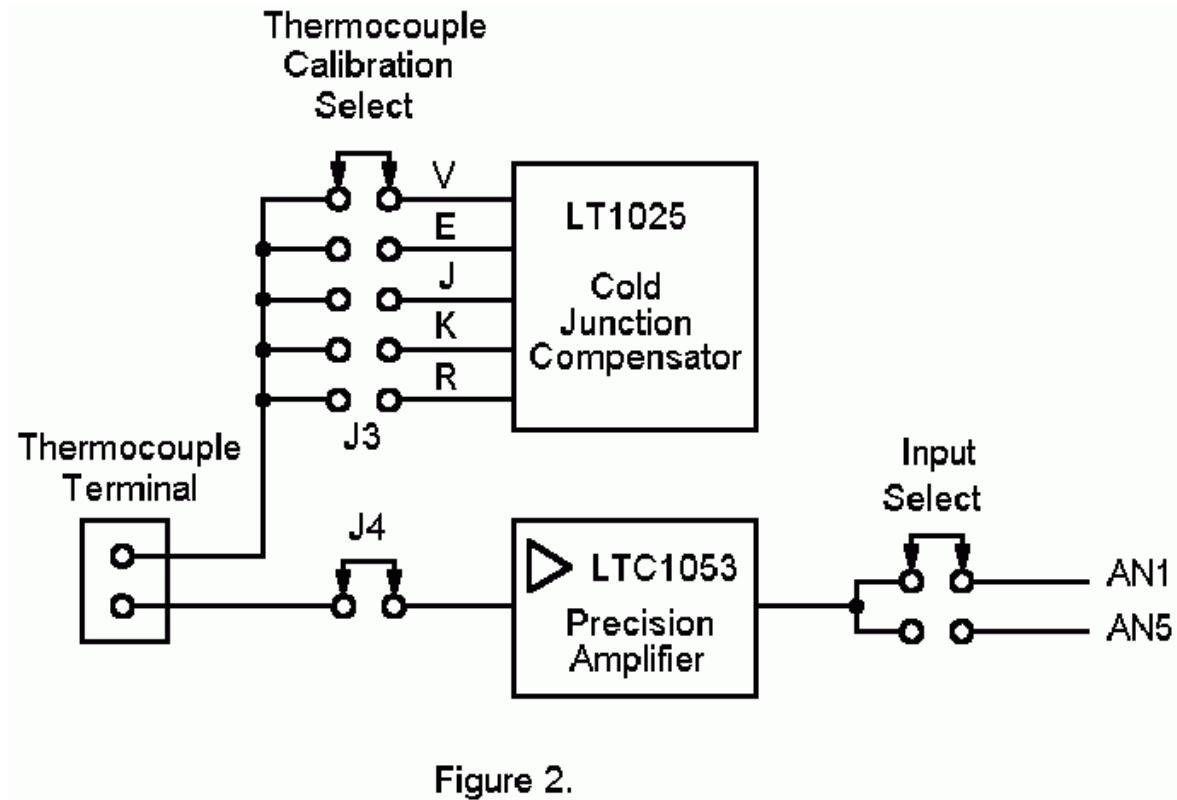

Figure 2.

Thermocouple calibration jumper should be set in accordance to thermocouple type used. J4 jumper is provided to compensate parasitic thermocouple of J3.

There are also J1 and J2 (Input select) jumpers. If J1 jumpers are installed, AN1 through AN4 analog inputs are used. If J2 jumpers are installed, used analog channels are AN5 through AN8. This feature allows connecting two THERMOCOUPLE-4 boards at the same time.

Unused amplifier inputs should be grounded with J6 jumpers. All amplifier channels have a gain of 137.

Thermocouple amplifiers outputs are wired to connector J7. Single +5V power supply for THERMOCOUPLE-4 board comes through this connector too (see Table 1). Table 1 shows the pin assignment of analog inputs and power sources of DAQ-2543 board.

Signal	Pin	Pin	Signal
AGND	1	2	AGND
AN3	3	4	AN1
+5V	5	6	+5V
AGND	7	8	AN0
AN4	9	10	AGND
+5V	11	12	AN2
AGND	13	14	+5V
AIN5	15	16	-
+5V	17	18	AGND
AGND	19	20	AIN7
AIN6	21	22	+5V
+5V	23	24	-
AGND	25	26	-

Table 1

5. Board layout

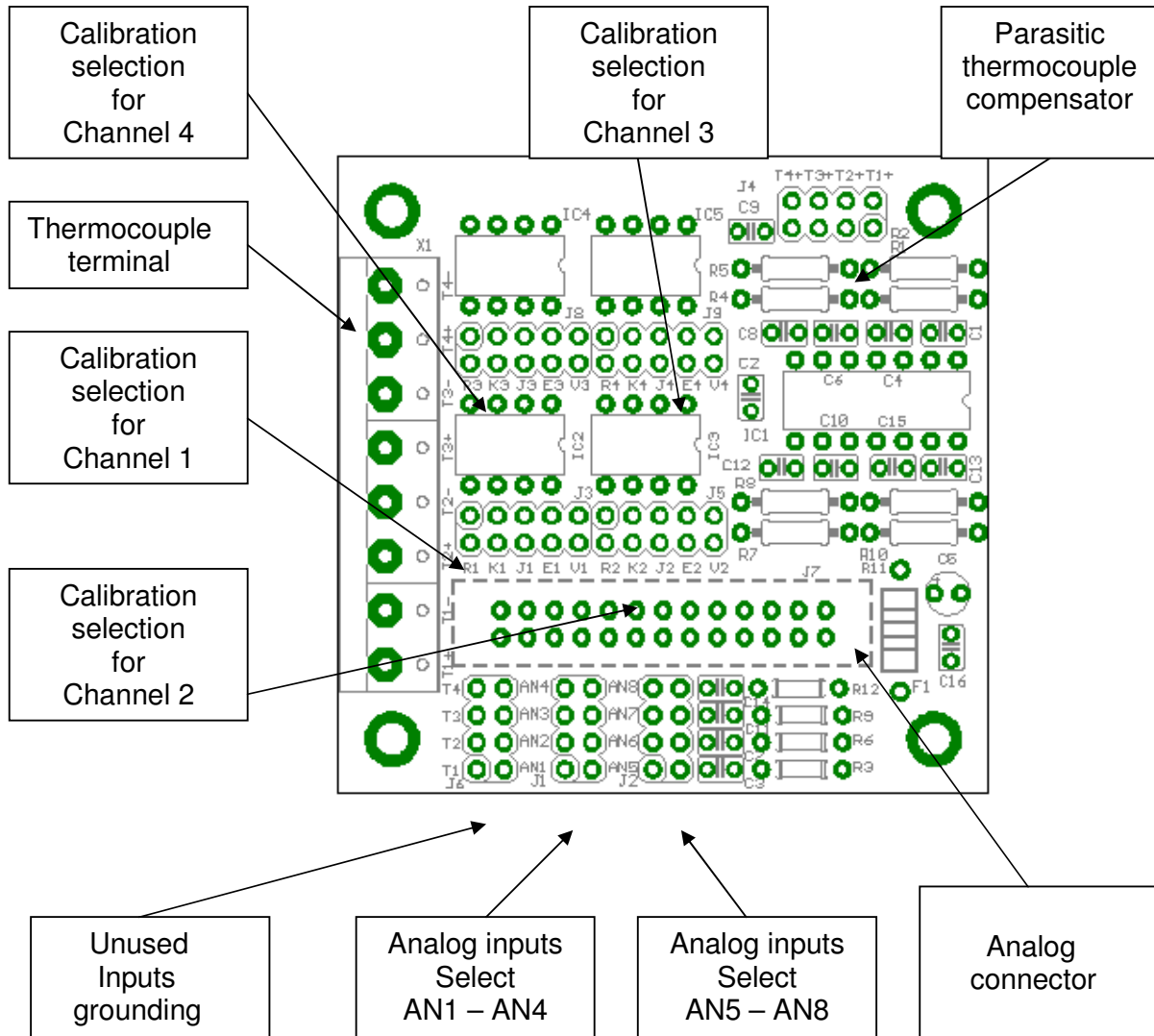

6. Schematics

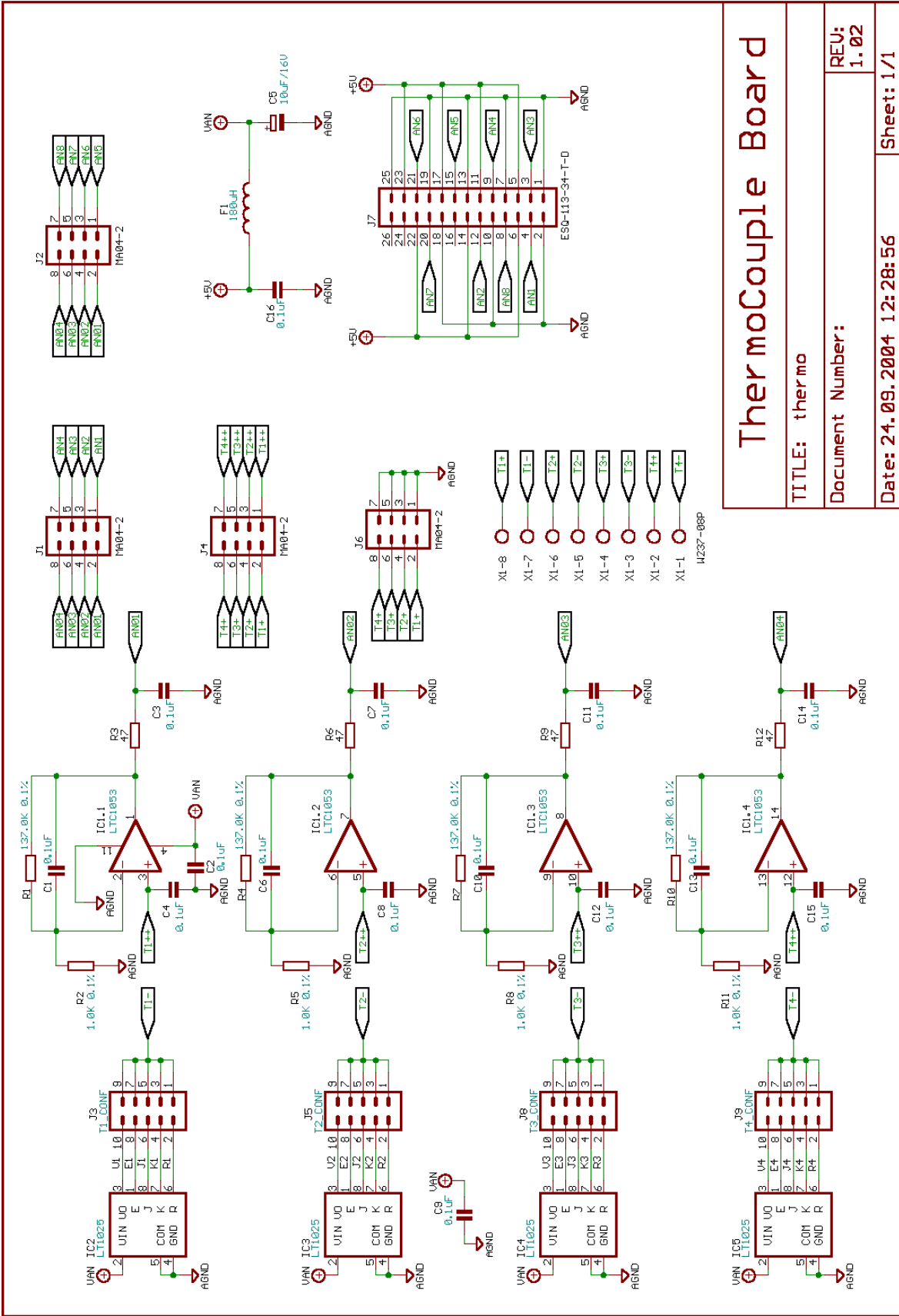

Ther moCouple Board

TITLE: ther mo	REV: 1.02
Document Number:	Sheet: 1/1
Date: 24.09.2004 12:28:56	