

Advanced Features 2 x 60A or 1 x 120A Variable Frequency Drive for AC Induction Motors



RoboteQ's FIM2360 is a features-packed, high-current, dual or single channel controller for AC Induction motors. The controller can operate in one of several modes in order to sense the rotor position and sequence power on the motors' 3 windings in order to generate smooth continuous rotation. The controller also uses the Encoder information to compute speed and measure travelled distance inside a 32-bit counter. The motors may be operated in open or closed loop speed or torque modes.

The FIM2360 features several Analog, Pulse and Digital I/Os which can be remapped as command or feedback inputs, limit switches, or many other functions. The FIM2360 accepts commands received from an RC radio, Analog Joystick, wireless modem, or microcomputer. For mobile robot applications, the controller's two motor channels can either be operated independently or mixed to move and steer a vehicle. Using CAN bus, up to 127 controllers can be networked at up to 1Mbit/s on a single twisted pair.

Numerous safety features are incorporated into the controller to ensure reliable and safe operation. The controller's operation can be extensively automated and customized using Basic Language scripts. The controller can be configured, monitored and tuned in real-time using a RoboteQ's free PC utility. The controller can also be reprogrammed in the field with the latest features by downloading new operating software from Roboteq.

Applications

- Automatic Guided Vehicles
- Small Electric Vehicles, Electric Bikes
- Terrestrial and Underwater Robotic Vehicles
- Police and Military Robots
- Hazardous Material Handling Robots
- Animatronics

Key Features

- USB, Serial, 0-5V Analog, or Pulse (RC radio) command modes
- One RS232 serial port
- CAN bus interface up to 1Mbit/s with multiple protocol support
- RS485 interface
- Auto switch between Serial, USB, CAN, Analog, or Pulse based on user-defined priority
- Built-in dual 3-phase high-power drivers for two AC Induction motors at up to 60A
- Output channels can be paralleled in order to drive a single motor at up to 120A
- Field Oriented Control
- Multiple Motor Operating mode
 - Open Loop Volts per Hertz
 - Fixed Slip Control
 - FOC Torque Mode
 - FOC Speed Mode
- Support for quadrature encoder
- Full forward & reverse motor control. Four quadrant operation. Supports regeneration
- Operates from a single 10V-60V power source
- STO-Safe Torque Off support (T-version) - Certification No. M6A 104504 0001 Rev. 00
- Programmable current limit up to 60A (120A on single channel version) per motor for protecting controller, motor, wiring and battery.
- Separate connector for Hall Sensors

- Accurate speed and Odometry measurement using Encoder data
- Up to 8 Analog Inputs for use as command and/or feed-back
- Up to 8 Pulse Length, Duty Cycle or Frequency Inputs for use as command and/or feedback
- Up to 10 Digital Inputs for use as Deadman Switch, Limit Switch, Emergency stop or user inputs
- Inputs for up to 2 Quadrature Encoders
- 4 general purpose 24V, 1.5A output for brake release or accessories
- Selectable min, max, center and dead band in Pulse and Analog modes
- Selectable exponentiation factors for each command inputs
- Trigger action if Analog, Pulse or Hall counter capture are outside user selectable range (soft limit switches)
- Built-in Battery Voltage and Temperature sensors
- Optional 12V backup power input for powering safely the controller if the main motor batteries are discharged
- Power Control wire for turning On or Off the controller from external microcomputer or switch
- No consumption by output stage when motors stopped
- Regulated 5V output for powering RC radio, RF Modem, sensors or microcomputer
- Separate Programmable acceleration and deceleration for each motor
- Ultra-efficient 2.5 mOhm ON resistance MOSFETs (1.25 mOhm on Single Channel)
- Stall detection and selectable triggered action if Amps is outside user-selected range
- Short circuit protection
- Overvoltage and Undervoltage protection
- Watchdog for automatic motor shutdown in case of command loss
- Overtemperature protection
- Diagnostic LED
- Efficient heat sinking. Operates without a fan in most applications.
- Dustproof and weather resistant. IP40rating
- Power wiring 0.25" Faston tabs
- 5.5" (139.7mm) L, 5.5" W (139.7mm), 1.0" (25mm) H
- -40o to +85o C operating environment
- 1 lbs (500g)
- Easy configuration, tuning and monitory using provided PC utility
- Field upgradeable software for installing latest features via the internet

Orderable Product References

Reference	Number of Channels	Amps/Channel	Volts	Ethernet	STO
FIM2360	2	60	60	No	No
FIM2360S	1	120	60	No	No
FIM2360T	2	60	60	No	Yes
FIM2360TS	1	120	60	No	Yes
FIM2360E	2	60	60	Yes	No
FIM2360ES	1	120	60	Yes	No
FIM2360TE	2	60	60	Yes	Yes
FIM2360TES	1	120	60	Yes	Yes

Important Safety Disclaimer

Dangerous uncontrolled motor runaway condition can occur for a number of reasons, including, but not limited to: command or feedback wiring failure, configuration error, faulty firmware, errors in user script or user program, or controller hardware failure.

The user must assume that such failures can occur and must make his/her system safe in all conditions. Roboteq will not be liable in case of damage or injury as a result of product misuse or failure.

Power Wires Identifications and Connection

Power connections are made by means of faston tabs located at the back of the controller.

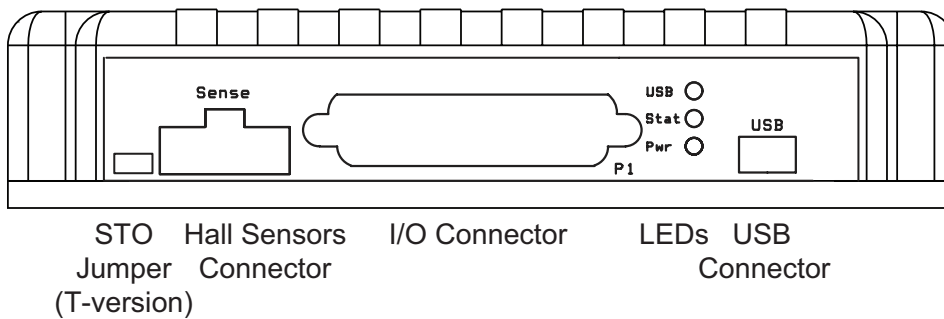

FIGURE 1. FIM2360 front view

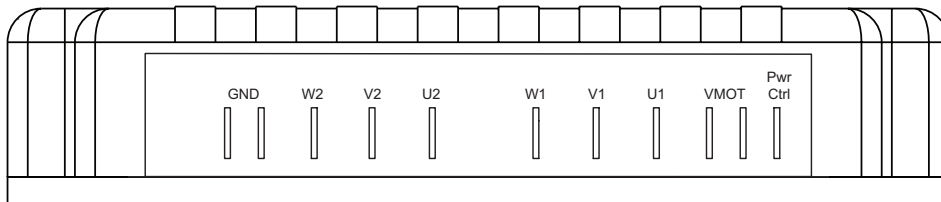

FIGURE 2. FIM2360 rear view

The diagram below shows how to wire the controller in a dual motor configuration, and how to turn power On and Off.

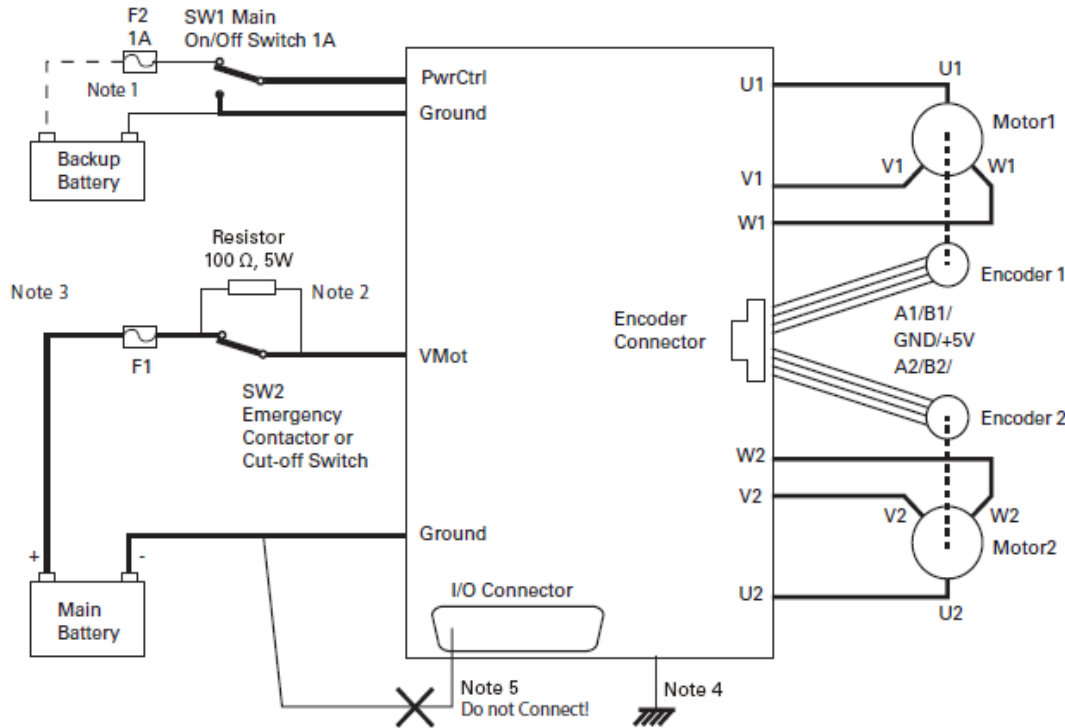

FIGURE 3. Powering the controller. Thick lines identify **MANDATORY** connections

Important Warning

Carefully follow the wiring instructions provided in the Power Connection section of the User Manual. The information on this datasheet is only a summary.

Mandatory Connections

It is imperative that the controller is connected as shown in the above diagram in order to ensure a safe and trouble-free operation. All connections shown as thick black lines are mandatory. The controller must be powered On/Off using switch SW1 on the PwrCtrl tab. Use a suitable high-current fuse F1 (check table 8) as a safety measure to prevent damage to the wiring in case of major controller malfunction.

Emergency Switch or Contactor

The battery must be connected in permanence to the controller's Vmot tabs via a high-power emergency switch or contactor SW2 as additional safety measure. The user must be able to deactivate the switch or contactor at any time, independently of the controller state.

Electrostatic Discharge Protection

In accordance with IEC 61000-6-4, Roboteq Motor Controllers are designed to withstand ESD up to 4kV touch and 8kV air gap. This protection is implemented without any additional external connections required.

Some specifications, such as EN12895, require a higher level of protection. To maximize ESD protection, up to 8kV touch and 15kV air gap, you may connect the metallic heatsink of the controller to your battery negative terminal. [See App Note 062918 for example connections.](#)

Precautions and Optional Connections

Note 1: Backup battery to ensure motor operation with weak or discharged batteries, connect a second battery to the Power Control wire/terminal via the SW1 switch.

Note 2: Use precharge 100Ω, 5W Resistor to prevent switch arcing.

Note 3: The voltage generated by motors rotating while not powered by the controller can cause serious damage even if the controller is Off or disconnected.

- Use the main SW1 switch on the Power Control wire/terminal to turn Off and keep Off the controller. In this way the controller cannot be powered up under any unwanted circumstances.
- Countermeasures should be taken to deal with any regeneration power if the battery or BMS system does not support energy to return back to it.
- Disconnecting the controller from the battery while motors are rotating could lead to a serious damage. In this case a regeneration brake system is needed.

Note 4: Connect the controller's bottom plate to a wire connected to the Earth while the charger is plugged in the AC main, or if the controller is powered by an AC power supply.

Note 5: Beware not to create a path from the ground pins on the I/O connector and the battery minus terminal.

Single Channel Wiring

On the Single Channel FIM2360S, the each of the motor wire must be connected to both output tabs of the same letter as shown in the figure below. Use the Encoders of Channel 1 for operation.

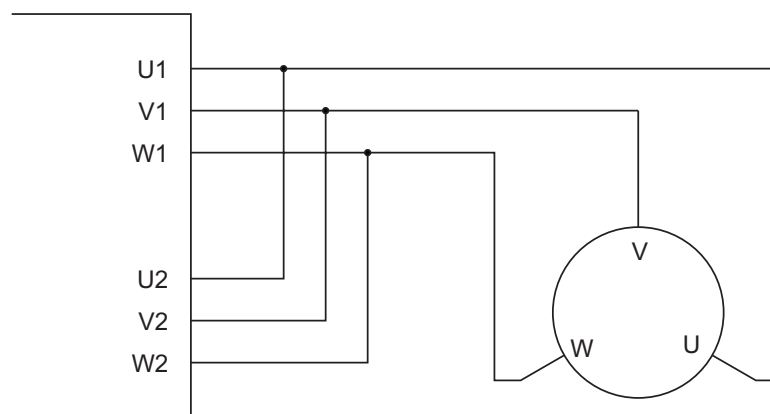

FIGURE 4. Single Channel wiring diagram

Important Warning

This wiring must be done only on the single channel version of the controller. Paralleling the wires on a dual channel product will cause permanent damage. Verify that your controller is an FIM2360S before you wire in this manner.

Use of Safety Contactor for Critical Applications

An external safety contactor must be used in any application where damage to property or injury to person can occur because of uncontrolled motor operation resulting from failure in the controller's power output stage.

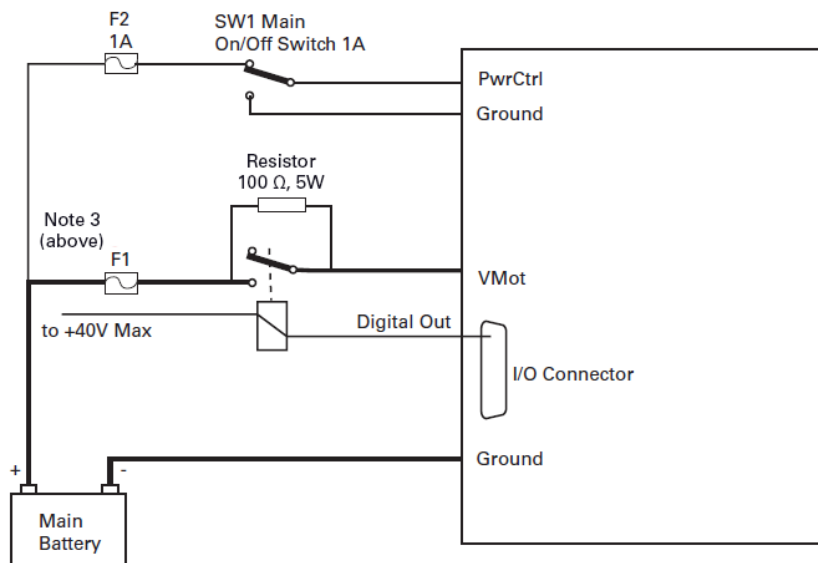

FIGURE 5. Contactor wiring diagram

The contactor coil must be connected to a digital output configured to activate when "No MOSFET Failure". The controller will automatically deactivate the coil if the output is expected to be off and battery current of 1A or more is measured for more than 0.5s. This circuit will not protect against other sources of failure such as those described in the "Important Safety Disclaimer" on page 3.

Controller Mounting

During motor operation, the controller will generate heat that must be evacuated. The published amps rating can only be fully achieved if adequate cooling is provided. Good conduction cooling can be achieved by having the bottom surface of the case making direct contact with a metallic surface (chassis, cabinet). The mounting has to be like that, so that the thermal-safety limits are not exceeded.

Encoder Connection

Connection to the Encoder is done using a special connector on the front side of the controller. The Hall sensor connector is a 10-pin Molex Microfit 3.0, ref. 43025-1000. Pin assignment is in the table below.

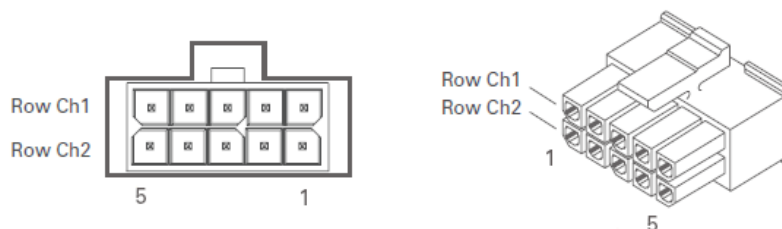

FIGURE 6. Encoder connector

Each input includes a 4.7K pull up resistor and can therefore accommodate encoders with open collector/open drain outputs. A 1nF capacitor to ground is present on each input for noise reduction.

TABLE 1.

Pin Number	1	2	3	4	5
Row Ch1	Ground	Enc1 A	Enc1 B		5V
Row Ch2	Ground	Enc2 A	Enc2 B		5V

Commands and I/O Connections

Connection to RC Radio, Microcomputer, Joystick and other low current sensors and actuators is done via the DB25 connector. The functions of many pins vary depending on controller model and user configuration. Pin assignment is found in the table below.

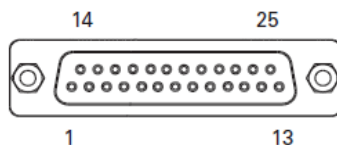

FIGURE 7. Main Connector pin locations

TABLE 2.

Connector Pin	Power	Dout	Com	Pulse	Ana	Dinput	Default Config
1	GND						
14	5VOut						
2			RSTxD				RS232Tx
15				RC1 (5)	ANA1	DIN1/STO1 (2)	RCRadio1 (3)
3			RS RxD				RS232Rx

TABLE 2.

Connector Pin	Power	Dout	Com	Pulse	Ana	Dinput	Default Config
16				RC2 (5)	ANA2	DIN2/STO2 (2)	RCRadio2 (3)
4				RC3	ANA3	DIN3	AnaCmd1 (1)
17				RC4 (6)	ANA4	DIN4	AnaCmd2 (1)
5	GND						
18		DOUT1					Motor Brake 1
6		DOUT2					Motor Brake 2
19		DOUT3					Contactora
7		DOUT4					Unused
20			CANH				Unused
8			CANL				Unused
21				RC5	ANA5	DIN5	Unused
9						DIN9	Unused
22				RC6	ANA6	DIN6	Unused
10						DIN10	Unused
23			485 +				RS485 +
11			485 –				RS485 –
24				RC7	ANA7	DIN7	Unused
12				RC8	ANA8	DIN8	Unused
25	5VOut						
13	GND						

Note 1: Analog command is disabled in factory default configuration.
 Note 2: STO functionality only available in T versions. See STO section for details.
 Note 3: Pulse input enable by default on firmware version prior to v2.0
 Note 5: Not recommended for MultiPWM on T versions.
 Note 6: Not recommended for MultiPWM.

Default I/O Configuration

While the controller can be configured so that practically any Digital, Analog and RC pin can be used for any purpose, the controller's factory default configuration provides an assignment that is suitable for most applications. The figure below shows how to wire the controller to two analog potentiometers, an RC radio, and the RS232 port. It also shows how to connect two outputs to motor brake solenoids and another output to an external status LED. You may omit any connection that is not required in your application. The controller automatically arbitrates the command priorities depending on the presence of a valid command signal in the following order: 1-RS232, 2-RC Pulse, 3-None. If needed, use the Roborun+ PC Utility to change the pin assignments and the command priority order.

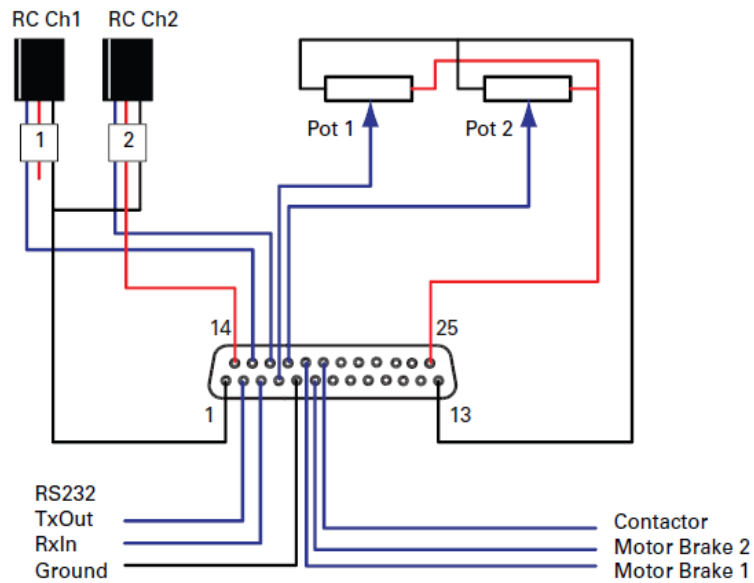

FIGURE 8. Factory default pins assignment

Enabling Analog Commands

For safety reasons, the Analog command mode is disabled by default. To enable the Analog mode, use the PC utility and set Analog in Command Priority 2 or 3 (leave Serial as priority 1). Note that by default the additional securities are enabled and will prevent the motor from starting unless the potentiometer is centered, or if the voltage is below 0.25V or above 4.75V. The drawing shows suggested assignment of Pot 1 to ANA1 and Pot 2 to ANA4. Use the PC utility to enable and assign analog inputs.

USB communication

Use USB only for configuration, monitoring and troubleshooting. USB is not a reliable communication method when used in an electrically noisy environments and communication will not always recover after it is lost without unplugging and replugging the connector, or restarting the controller. Always prefer RS232 communication when interfacing to a computer. USB and CAN can operate at the same time on the FIM2360. Plugging USB to a computer will not disable CAN interface.

RS485 communication

RS485 is an industry standard for defining serial communication. Due to its balanced signalling, RS485 is effective over distances, even if other electrical signals are present. Its stability makes it well suited to connect multiple receivers to a single network.

You can operate RS485 in half-duplex mode and it is well suited for use with the Modbus protocol. On the 25-pin connector, RS485+ and RS485- pins are present.

Ethernet communication

Ethernet communication is currently only available on the E versions of applicable Roboteq product. There is a connection port on the top of the unit for easy and rapid access. While the TCP and ModbusTCP protocols are supported, Serial is the preferred method to access all native commands.

Status LED Flashing Patterns

After the controller is powered on, the Power LED will turn on, indicating that the controller is On. The Status LED will be flashing at a two second interval. The flashing pattern and colour provides operating or exception status information.

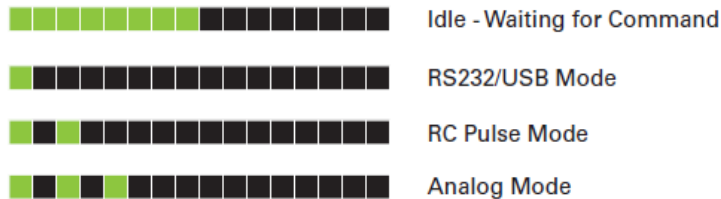

FIGURE 9. Normal Operation Flashing Patterns

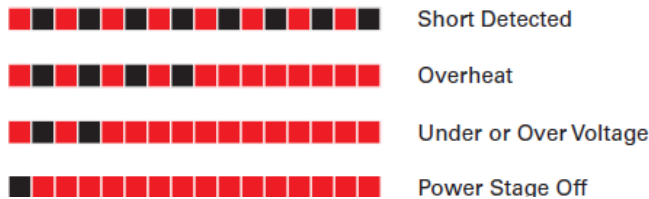

FIGURE 10. Exception or Fault Flashing Patterns

Additional status information may be obtained by monitoring the controller with the PC utility.

The communication LED gives status information on the CAN and USB.

The communication LED gives status information on the CAN and USB.

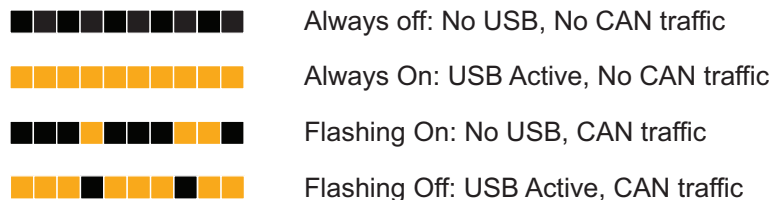

FIGURE 11. Communication LED Flashing Patterns

Battery Backed Clock and Variables

The battery backed clock and variables feature allows accurate time/date stamping of information such as status and error reports. It is important to note that the only Roboteq products that include this feature are ones that specifically say that battery backed clock is a product feature. If your Roboteq product has displayed time/date information but the product does not specifically list the battery backed clock as a feature, then the information displayed is random and not accurate.

The location of the battery is dependent on the product. However, any Roboteq product with this feature will run it on a 3V, 12.5mm coin style battery. The clock is accessible via the ^BEE commands and user input variables will remain even if the unit is powered off.

Please Note: Customers will be required to install the battery for the clock (type BR-1225), themselves. Units do not ship with the battery for the Battery Backed Clock, installed.

Safe Torque Off - STO (Certification No. M6A 104504 0001)

Safe Torque Off is a safe method for switching controller in a state where no torque is generated, regardless whether the controller is operating normally or is faulty. When STO is enabled, two digital inputs, DIN1 and DIN2 are remapped as STO1 and STO2. The inputs are redundant and both must have a 6V to 30V signal present at the same time in order for the Power MOSFETs to be energized. The controller will perform a self-check of the STO circuit at every power on and every time the STO inputs go from any state to both high. Once the STO hardware is verified to work, the controller will safely allow the motors to be energized. If either input is below 1V, the controller's outputs will be disabled. The STO circuit is verified and validated and can therefore be trusted instead of external relays. See [STO Manual](#) for more information and maintenance instructions.

By factory default STO functionality is disabled. It must be enabled by removing the jumper located on the controller's PCB. STO functionality is only available in the T version of the controller.

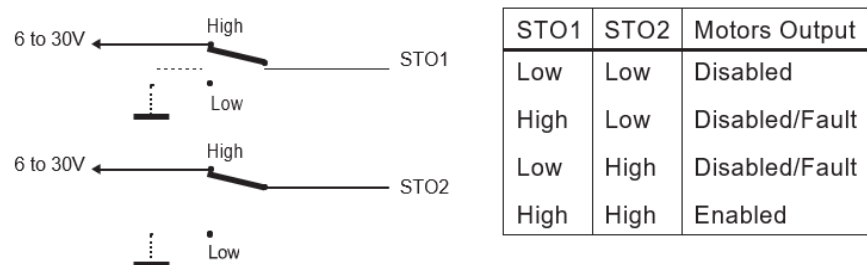

FIGURE 12. STO input levels effects on controller output

The STO function is compliant to:

- IEC 61800-5-2:2007, SIL 3
- IEC 61508:2010, SIL 3
- IEC 62061:2005, SIL 3
- ISO 13849-1:2015, Category 3 Performance Level e

Important Warning

Activating STO does lead to no more torque generation on the motor. The motor will not be actively stopped but run out. In case of a multiple fault in the power stage a rotation might occur.

Secure Connection to AMP FASTON™ Tabs

Power Motor and Battery connections are made via standard 250mils (6.35mm) AMP FASTON Tabs. FASTON connectors provide a high current and very secure connection, proven over decades of use in the automotive industry. For maximum current handling, use connectors for AWG8 wires.

FASTON connectors have an extremely tight fit and will not come off on their own. It is recommended, nevertheless, that the wiring is made so that the cables are never pulling the connector outward.

Frequent disconnects and reconnects will eventually loosen the connector's grip on the tab. If frequent disconnection is required, consider using Positive Lock connectors from TE Connectivity or their equivalent. These connectors have a spring-loaded tab latch pin that will lock into the hole of the male tab.

Electrical Specifications

Absolute Maximum Values

The values in the table below should never be exceeded, permanent damage to the controller may result.

TABLE 3.

Parameter	Measure point	Min	Typical	Max	Units
Battery Leads Voltage	Ground to Vmot			60	Volts
Reverse Voltage on Battery Leads	Ground to Vmot	-1			Volts
Power Control Voltage	Ground to Pwr Control wire			60	Volts
Motor Leads Voltage	Ground to U, V, W wires			60 (1)	Volts
Digital Output Voltage	Ground to Output pins			30	Volts
Analog and Digital Inputs Voltage	Ground to any signal pin on DB25 & Encoder inputs			30	Volts
RS232 I/O pins Voltage	External voltage applied to Rx pins			30 (2)	Volts
Case Temperature	Case	-40		85	°C
Humidity	Case			100 (3)	%
Note 1: Maximum regeneration voltage in normal operation. Never inject a DC voltage from a battery or other fixed source					
Note 2: Non-condensing					
Note 3: Non condensing					

Power Stage Electrical Specifications (at 25°C ambient)

TABLE 4.

Parameter	Measure point	Model	Min	Typ	Max	Units
Input Voltage	Ground to Vmot	All	0 (1)		60	Volts
Input continuous Max Current	Power source current	All			80	Amps
Output Voltage	Ground to U, V, W wires	All	0 (1)		60 (2)	Volts
Power Control Voltage	Ground to Power Control wire	All	0 (1)		65	Volts
Minimum Operating Voltage	VBat or PwrCtrl wires	All	10 (3)			Volts
Over Voltage protection range	Ground to Vmot	All	5	60 (4)	63	Volts
Under Voltage protection range	Ground to Vmot	All	0	5 (4)	63	Volts
Idle Current Consumption	Vmot or PwrCtrl wires	All	50	100 (5)	150	mA
ON Resistance (Excluding wire resistance)	Vmot to U, V or W. Ground to U, V or W	FIM2360		2.5		mOhm
		FIM2360S		1.25		mOhm
Max Current for 30s	Motor current	FIM2360			60	Amps
		FIM2360S			120	Amps
Continuous Max Current per channel	Motor current	FIM2360			40 (6)	Amps
		FIM2360S			80 (6)	Amps
Current Limit range	Motor current	FIM2360	10	50 (7)	60	Amps
		FIM2360S	20	100 (7)	120	Amps
Stall Detection Amps range	Motor current	FIM2360	10	60 (7)	60	Amps
		FIM2360S	20	120 (7)	120	Amps
Stall Detection timeout range	Motor current	All	1	500 (8)	65000	msec
Short Circuit Detection threshold (9)	Between Motor wires or Between Motor wires and ground or Between Motor wires and Vmot	FIM2360			110(10)	Amps
		FIM2360S			220 (10)	Amps
Motor Acceleration/Deceleration range	Motor Output	All	100	500(11)	65000	msec
Power cable thickness	Power input and output	All		8		AWG
Note 1: Negative voltage will cause a large surge current. Protection fuse needed if battery polarity inversion is possible						
Note 2: Maximum regeneration voltage in normal operation. Never inject a DC voltage from a battery or other fixed source						
Note 3: Minimum voltage must be present on VBat or Power Control wire						
Note 4: Factory default value. Adjustable in 0.1V increments						
Note 5: Current consumption is lower when higher voltage is applied to the controller's VBat or PwrCtrl wires						
Note 6: Estimate. Limited by case temperature. Current may be higher with better cooling						
Note 7: Factory default value. Adjustable in 0.1A increments						
Note 8: Factory default value. Time in ms that Stall current must be exceeded for detection						
Note 9: Controller will stop until zero command given in case of short circuit detection						
Note 10: Approximate value						
Note 11: Factory default value. Time in ms for power to go from 0 to 100%						

Command, I/O and Sensor Signals Specifications

TABLE 5.

Parameter	Measure point	Min	Typical	Max	Units
Main 5V Output Voltage	Ground to 5V pins on	4.6	4.9	5.2	Volts
5V Output Current	5V pins on RJ45 and DSub15			200 (1)	mA
Encoder Resolution	Encoder inputs			128	PPR
Digital Output Voltage	Ground to Output pins			128	Volts
Output On resistance	Output pin to ground		0.25	0.5	Ohm
Output Short circuit threshold	Output pin	1.7		3.5	Amps
Digital Output Current	Output pins, sink current			1.5	Amps
Input Impedances (except DIN11-19)	AIN/DIN Input to Ground		53		kOhm
Digital Input 0 Level	Ground to Input pins	-1		1	Volts
Digital Input 1 Level	Ground to Input pins	3		15	Volts
Analog Input Range	Ground to Input pins	0		5.1	Volts
Analog Input Precision	Ground to Input pins		0.5		%
Analog Input Resolution	Ground to Input pins		1		mV
Encoder Frequency				500	kHz
Pulse durations	Pulse inputs	20000		10	us
Pulse repeat rate	Pulse inputs	50		250	Hz
Pulse Capture Resolution	Pulse inputs		1		us
Frequency Capture	Pulse inputs	100		10000	Hz
Minimum Pulse on or Pulse off duration	Pulse inputs	25			us

Note 1: Sum of all 5VOut outputs

Operating & Timing Specifications

TABLE 6.

Parameter	Measure Point	Min	Typical	Max	Units
Command Latency	Command to output change	0	0.5	1	ms
Maximum PWM duty cycle	Motor Output			93.8	%
Closed Loop update rate	Internal		1000		Hz
RS232 baud rate	Rx and Tx pins		115200 (1)		Bits/s
RS232 Watchdog timeout	Rx pin	1 (2)		65000	ms

Note 1: 115200, 8-bit, no parity, 1 stop bit, no flow control

Note 2: May be disabled with value 0

Motor Characteristics Requirement for FOC current control

For proper FOC current control and motor operation under sinusoidal commutation, it is necessary for the motor to meet a minimum load inductance, minimum load L/R and maximum electric operating speed requirements. The minimum required inductance is necessary in order to ensure low Total Harmonic Distortion (THD) of the motor current. Furthermore, to achieve proper current response and stability, the controller’s current loop sampling rate will limit the minimum permissible motor time constant $\tau=L/R$ and the maximum operating electric speed.

TABLE 7.

Parameter	Input DC Voltage (V)	Value	Units
Minimum load phase inductance (1)	12	25	uH
	24	40	uH
	48	60	uH
	60	80	uH
Minimum load inductance/resistance ratio (1)	0 - 60	1	msec
Maximum operating electric speed (2)	0 - 60	15000	RPM
Note 1: Star connected three phase load considered. In case the motor phase inductance does not fulfill the above requirements (minimum phase inductance and inductance/resistance ratio) an external AC inductor with proper inductance value is recommended to be added.			
Note 2: Maximum rotor speed is calculated from the maximum operating electric speed and pole pairs. For example, in a motor with 4 pole pairs the maximum operating rotor speed is $15000/4 = 3750$ rpm			

Scripting

TABLE 8.

Parameter	Measure Point	Min	Typical	Max	Units
Scripting Flash Memory	Internal		32K		Bytes
Integer Variables	Internal		4096		Words (1)
Boolean Variables	Internal		8192		Symbols
Execution Speed (2)	Internal	30,000		70,000	Lines/s
Note 1: 32-bit words					
Note 2: Execution Speed was calculated based on low communication load with the controller. In high communication workload, minimum time might be reduced drastically.					

Thermal Specifications

TABLE 9.

Parameter	Measure Point	Min	Typical	Max	Units
Case Temperature	Case	-40		85 (1)	°C
Thermal Protection range	Case	80		90 (2)	°C
Power Dissipation	Case			70	Watts
Thermal resistance	Power MOSFETs to case			0.6	°C/W
Humidity	Case			95	%
Ambient temperature	Ambient			55	°C
Pollution Degree	-			PD 2	
Fast fuse to install (3)	FIM2360 (4)	40		2 x 40	Amps
	FIM2360S (4)		2 x 40		Amps
Overload motor protection	-			Check note 5	
Note 1: Thermal protection will protect the controller power					
Note 2: Max allowed power out starts lowering at minimum of range, down to 0 at max of range					
Note 3: There are two power terminal tabs. Fuse should be installed in both of them for safety.					
Note 4: In dual channel controller, for operating only one channel install 40A fuse and for operating both channels 2 x 40A fuse should be installed. Power source must be capable to blow the fuse instantly in case of short circuit					
Note 5: Current limiting mechanism available through firmware. External overload motor protection can be used if required (provided by user)					

Mechanical Specifications

TABLE 10.

Parameter	Measure Point	Min	Typical	Max	Units
Weight	Board		500 (1)		g (lbs)
Power Connectors width	Terminal tab		0.25		Inches

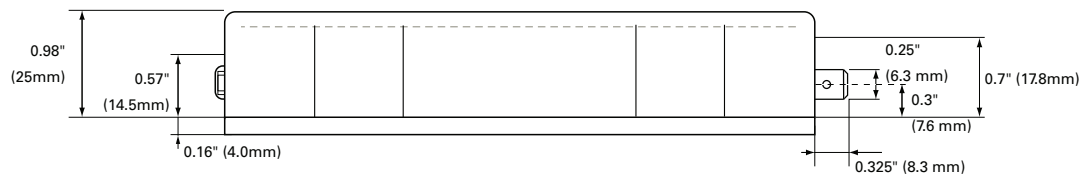

FIGURE 13. FIM2360 side view and dimensions

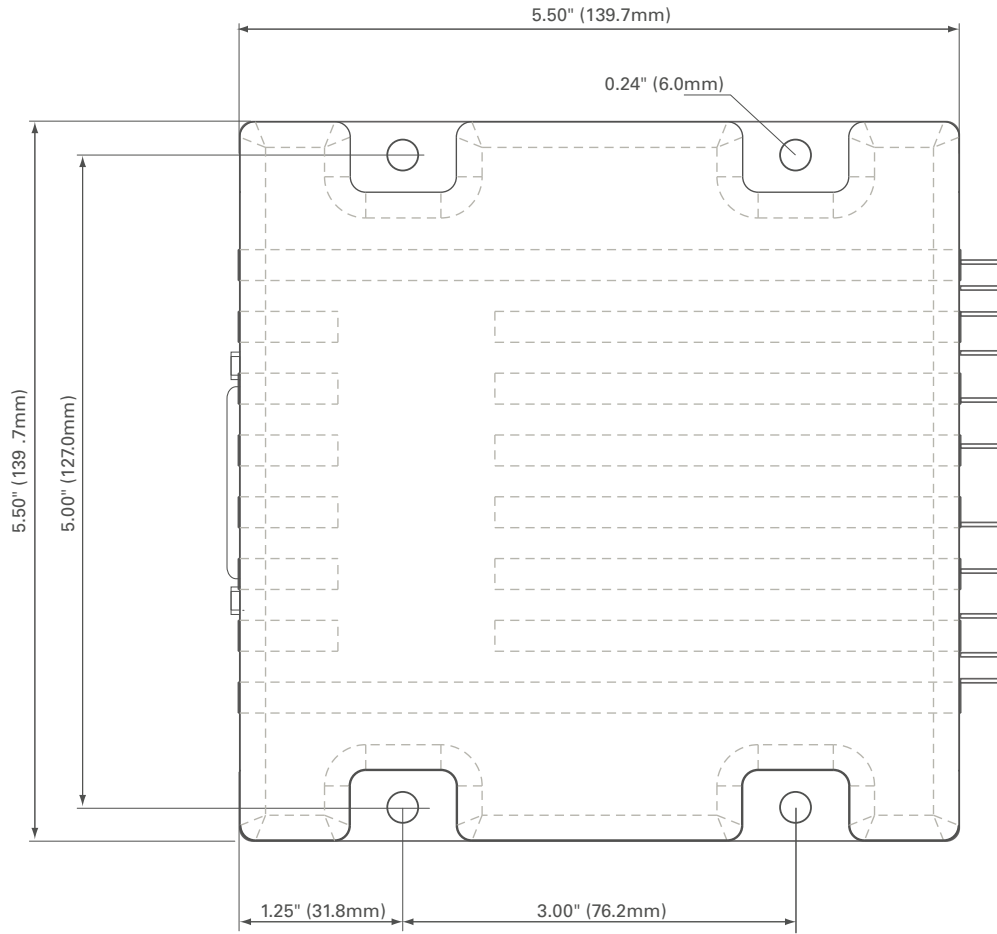

FIGURE 14. FIM2360 top view and dimensions

Revision history

Revision	Date	Additions/Changes
1.1	August 29, 2019	STO certification changes