

120A Forward/Reverse Brushless DC Motor Controller with Hall and Encoder Inputs, USB and CAN



Roboteq's MBL1xxx is a features-packed, medium-current single channel controller for brushless DC motors. Available in 30V and 60V versions, the controller can operate in one of several modes in order to sense the rotor position and sequence power on the motors' 3 windings in order to generate smooth continuous rotation. The controller also uses the Hall sensor and/or Encoder information to compute speed and measure traveled distance. The motors may be operated in open or closed loop speed mode, position mode or in torque mode. The MBL1xxx features several Analog, Pulse and Digital I/Os which can be remapped as command or feedback inputs, limit switches, or many other functions. The MBL1xxx accepts commands received from an RC radio, Analog Joystick, wireless modem, or microcomputer. Using CAN bus, up to 127 controllers can be networked at up to 1Mbit/s on a single twisted pair.

The controller's operation can be extensively automated and customized using Basic Language scripts. The controller can be configured, monitored and tuned in realtime using a Roboteq's free PC utility. The controller can also be reprogrammed in the field with the latest features by downloading new operating software from Roboteq.

Applications

- Small Electric Vehicles, Electric Bikes
- Electric Boats
- Terrestrial and Underwater Robotic Vehicles
- Automatic Guided Vehicles
- Police and Military Robots
- Hazardous Material Handling Robots
- Telepresence Systems
- Animatronics
- Industrial Controls
- Hydraulic Pumps control

Key Features

- RS232, 0-5V Analog, or Pulse (RC radio) command modes
- Auto switch between RS232, Analog, or Pulse based on user-defined priority
- CAN bus interface at up to 1Mbit/s
- Built-in 3-phase high-power drivers for one brushless DC motor at up to 120A (MBL16xx) or 75A (MBL13xx)
- Trapezoidal switching based on Hall Sensor position information
- Trapezoidal Sensorless (A-version)
- Smooth and quiet 3 Phase sinusoidal mode (A-version)
- Support for absolute angle encoders (A-version)
 - sin/cos analog
 - SSI digital
 - Resolver
- Field Oriented Control in Sinusoidal modes
- Full forward & reverse motor control. Four quadrant operation. Supports regeneration
- Operates from a single power source
- Programmable current limit up to 120A (75A) for protecting controller, motor, wiring and battery.
- Connector for Hall Sensors
- Accurate speed and Odometry measurement using Hall Sensor or encoder data
- Quadrature encoder input with 32-bit counter
- Up to 6 Analog Inputs for use as command and/or feedback
- Up to 6 Pulse Length, Duty Cycle or Frequency Inputs for use as command and/or feedback
- Up to 6 Digital Inputs for use as Deadman Switch, Limit Switch, Emergency stop or user inputs

- Two general purpose 40V, 1.5A output for brake release or accessories
- Custom scripting in Basic language. Execution speed 50000 lines per second
- Selectable min, max, center and deadband in Pulse and Analog modes
- Selectable exponentiation factors for each command inputs
- Trigger action if Analog, Pulse, Encoder or Hall counter capture are outside user selectable range (soft limit switches)
- Open loop or closed loop speed control operation
- Closed loop position control with encoder, analog or pulse/frequency feedback
- PID control loop
- Support for CANopen and two simplified CAN protocols
- Configurable Data Logging of operating parameters on RS232 Output for telemetry or analysis
- Built-in Battery Voltage and Temperature sensors
- Optional 12V backup power input for powering safely the controller if the main motor batteries are discharged
- Power Control wire for turning On or Off the controller from external microcomputer or switch
- No consumption by output stage when motors stopped
- Regulated 5V output for powering RC radio, RF Modem or microcomputer
- Separate Programmable acceleration and deceleration for each motor
- Ultra-efficient 1.5 mOhm (MBL16xx) or 3.0mOhm (MBL13xx) ON resistance MOSFETs
- Auto stop if no motion is detected
- Stall detection and selectable triggered action if Amps is outside user-selected range
- Short circuit protection with selectable sensitivity levels
- Overvoltage and Undervoltage protection
- Watchdog for automatic motor shutdown in case of command loss
- Overtemperature protection
- Diagnostic LED
- Efficient heat sinking using conduction bottom plate. Operates without a fan in most applications
- Power wiring via FASTON terminals
- 5.50" (140mm) L, 4.45" W (113mm), 1.14" (29mm) H
- -40o to +85o C operating environment
- 3.5oz (100g)
- Easy configuration, tuning and monitory using provided PC utility
- Field upgradeable software for installing latest features via the internet

Orderable Product References

Reference	Number of Channels	Amps/Channel	Volts	FOC
MBL1330	1	75	30	No
MBL1330A	1	75	30	Yes
MBL1660	1	120	60	No
MBL1660A	1	120	60	Yes

Important Safety Disclaimer

Dangerous uncontrolled motor runaway condition can occur for a number of reasons, including, but not limited to: command or feedback wiring failure, configuration error, faulty firmware, errors in user script or user program, or controller hardware failure.

The user must assume that such failures can occur and must make his/her system safe in all conditions. Roboteq will not be liable in case of damage or injury as a result of product misuse or failure.

Power Wires Identifications and Connection

Power connections are made through FASTON tabs. For more power handling the Supply and Motor tabs are doubled and should be connected in parallel.

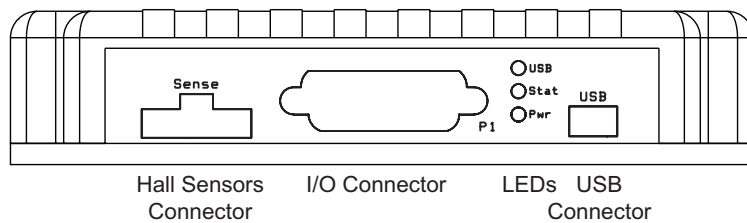

FIGURE 1. MBL1xxx front view

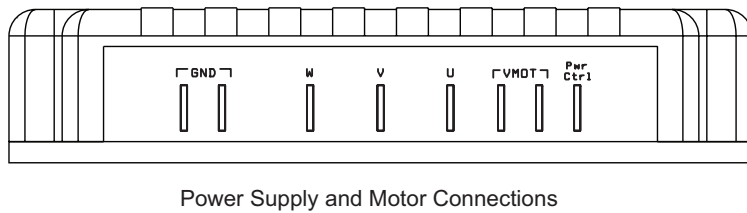

FIGURE 2. MBL1xxx rear view

The diagram below shows how to wire the controller and how to turn power On and Off.

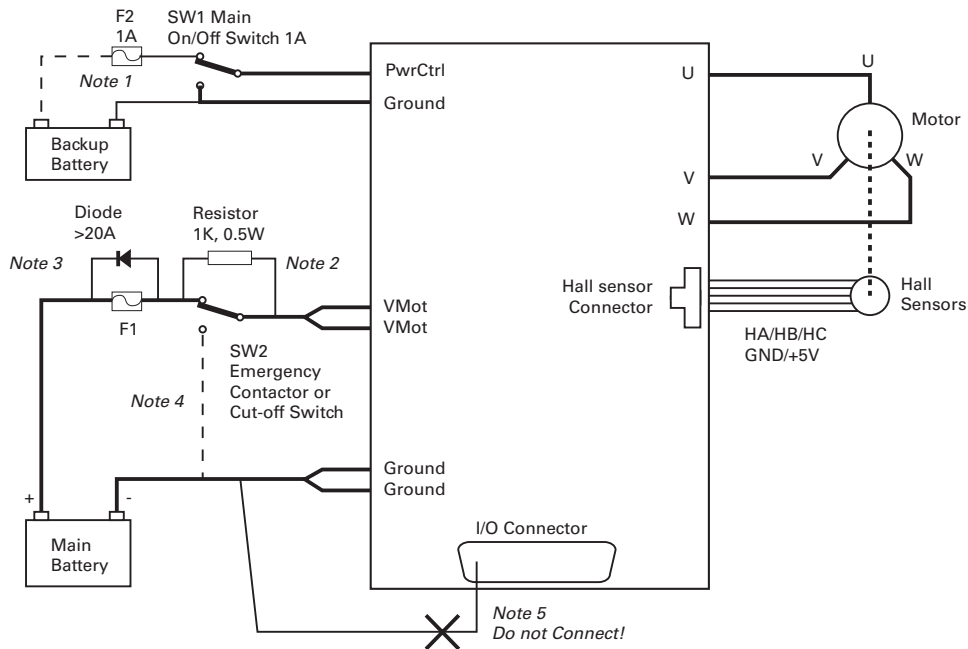

FIGURE 3. Powering the controller. Thick lines identify MANDATORY connections

Important Warning

Carefully follow the wiring instructions provided in the Power Connection section of the User Manual. The information on this datasheet is only a summary.

Mandatory Connections

It is imperative that the controller is connected as shown in the above diagram in order to ensure a safe and trouble-free operation. All connections shown as thick black lines are mandatory. The controller must be powered On/Off using switch SW1 on the Power Control tab. Use a suitable high-current fuse F1 as a safety measure to prevent damage to the wiring in case of major controller malfunction.

Emergency Switch or Contactor

The battery must be connected in permanence to the controller's VMot tab via a high-power emergency switch or contactor SW2 as additional safety measure. The user must be able to deactivate the switch or contactor at anytime, independently of the controller state.

Precautions and Optional Connections

Note 1: Backup battery to ensure motor operation with weak or discharged batteries, connect a second battery to the Power Control wire/terminal via the SW1 switch.

Note 2: Use precharge 1K, 0.5W Resistor to prevent switch arcing.

Note 3: Insert a high-current diode to ensure a return path to the battery during regeneration in case the fuse is blown.

Note 4: Optionally ground the VMot input when the controller is Off if there is any concern that the motors could be made to spin and generate voltage in excess of 30V (MBL1330) or 62V (MBL1660).

Note 5: Beware not to create a path from the ground pins on the I/O connector and the battery minus terminal.

Use of Safety Contactor for Critical Applications

An external safety contactor must be used in any application where damage to property or injury to person can occur because of uncontrolled motor operation resulting from failure in the controller's power output stage.

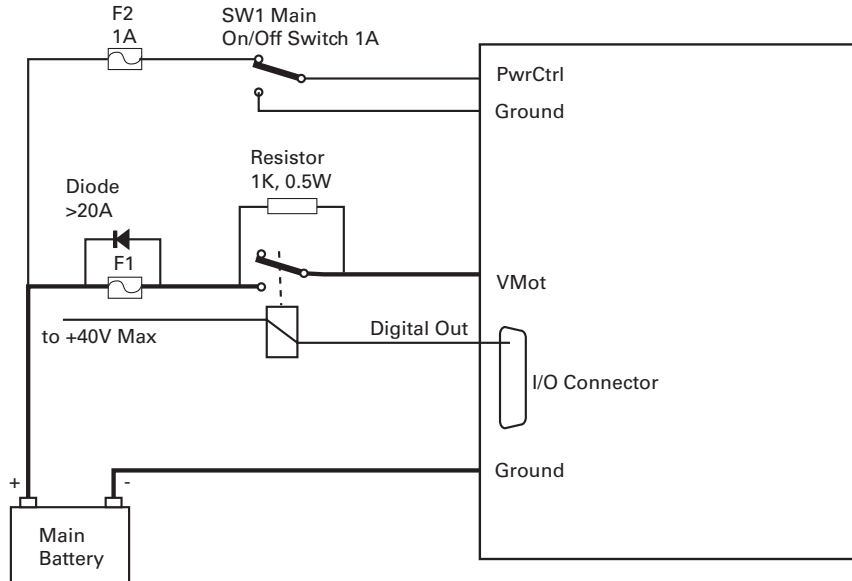

FIGURE 4. Contactor wiring diagram

The contactor coil must be connected to a digital output configured to activate when "No MOSFET Failure". The controller will automatically deactivate the coil if the output is expected to be off and battery current of 1A or more is measured for more than 0.5s. This circuit will not protect against other sources of failure such as those described in the "Important Safety Disclaimer" on page 3.

Controller Mounting

During motor operation, the controller will generate heat that must be evacuated. The published amps rating can only be fully achieved if adequate cooling is provided. Mount the controller so that the bottom plate makes contact with a metallic surface (chassis, cabinet) to conduct the heat.

Hall Sensors Connection

The Hall sensor connector is a 6-pin Molex Microfit 3.0, model 43645. Pin assignment is in the table below.

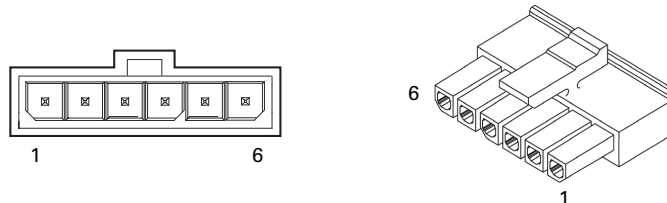

FIGURE 5. Hall Sensors connector

TABLE 1.

Pin Number	1	2	3	4	5	6
Signal	5V	Reserved	Hall C	Hall B	Hall A	Ground

Hall Sensor vs Motor Output sequencing

The controller requires the Hall sensors inside the motor to be 120 degrees apart. The controller's 3-phase bridge will activate each of the motor winding according to the sequence shown in the figure below

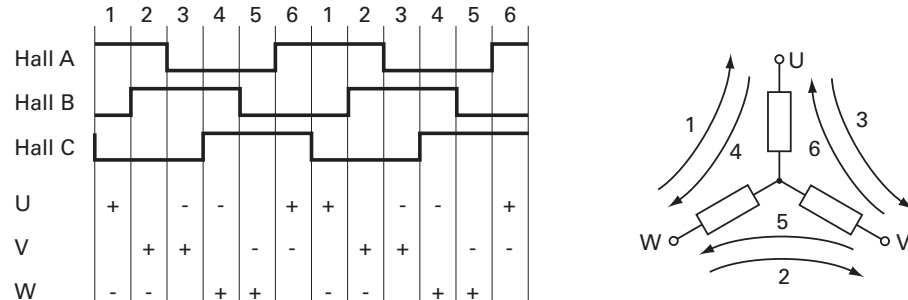

FIGURE 6. Hall Sensors sequence

Connection to SSI Absolute Encoder (A-version)

In Sinusoidal Mode, the controller can use motors equipped with absolute angle sensors with SSI interface. When enabled, the SSI signals are found on the 6-pin Molex connector that is otherwise used for the Hall Sensors. The controller issues a clock signal to, and receives data signal from the encoder.

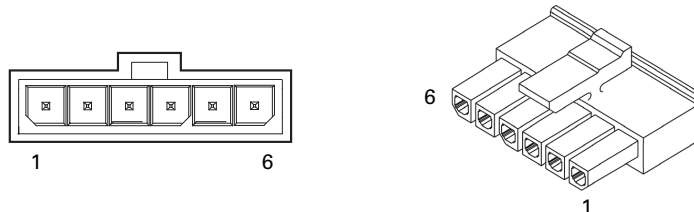

FIGURE 7. Hall Sensor connector used for SSI encoders

TABLE 2.

Pin Number	1	2	3	4	5	6
Signal	5V	Clock -	Clock +	Data -	Data +	Ground

Connection to Analog Sin/Cos Absolute Encoder (A-version)

The MBL1xxxA have 2 high-speed analog inputs that can be used to capture absolute angle position from angular sensors with sin/cos voltage outputs. The signal must be 0-5V max with the 0 at 2.500V.

The table below shows the signals assignment on the 15-pin connector.

TABLE 3.

Signal	Pin Number	Pin Name
Sin	10	ANA5/ASIN
Cos	15	ANA6/ACOS

Connecting Resolver (A-version)

Resolver wiring is similar to a Sin/Cos sensor with the addition of an excitation signal. Diagram below shows the necessary connections.

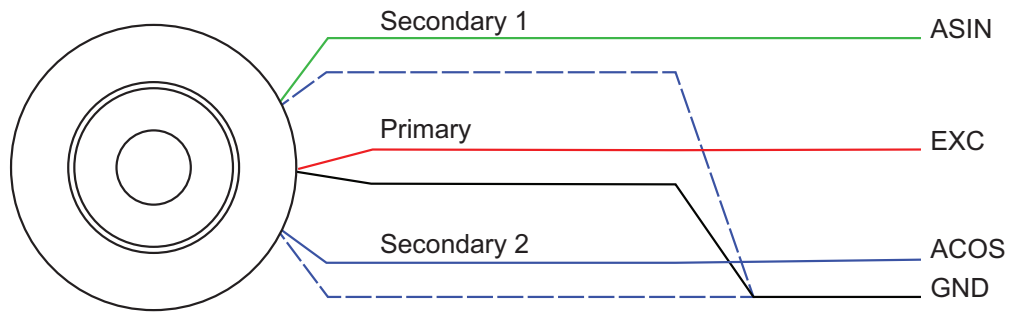

The table below shows the signals assignment on the 15-pin connector.

TABLE 4.

Signal	Pin Number	Pin Name
Sin	10	ANA5/ASIN
Cos	15	ANA6/ACOS
Exc	11	ANA4/EXC

Commands and I/O Connections

Connection to RC Radio, Microcomputer, Joystick and other low current sensors and actuators is done via the 15-pin connector located in front of the controller. The functions of many pins vary depending on controller model and user configuration. Pin assignment is found in the table below.

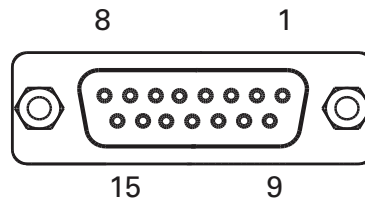

FIGURE 8. Connector pin locations

TABLE 5.

Connector Pin	Power	Dout	Com	RC	Ana	Dinput	Enc	Default Config
1		DOUT1 (1)						Brake
9		DOUT2 (1)						Contactora
2			TxOut					RS232Tx
10				RC5 (5)	ANA5/ASIN (6)	DIN5		Unused
3			RxIn					RS232Rx
11				RC4	ANA4/EXC (6)	DIN4		AnaCmd (3)
4				RC1	ANA1	DIN1	ENCA (2)	RCRadio1
12				RC3	ANA3	DIN3		Unused
5	GND							
13	GND							
6			CANL (4)					CAN Low
14	5VOut							
7			CANH (4)					CAN High
15				RC6 (5)	ANA6/ACOS (6)	DIN6		Unused
8				RC2	ANA2	DIN2	ENCB (2)	Unused

Note 1: Outputs are Open Drain. They pull to ground when on and float when off. Load must be connected between output and positive voltage.

Note 2: Encoder input requires RC inputs 1 and 2 to be disabled. Encoder is disabled in factory default.

Note 3: Analog command is disabled in factory default configuration.

Note 4: CAN and USB can operate simultaneously only on A-version.

Note 5: Only present on A-version.

Note 6: ASIN, ACOS, EXC only present on A-version.

Default I/O Configuration

The controller can be configured so that practically any Digital, Analog and RC pin can be used for any purpose. The controller's factory default configuration provides an assignment that is suitable for most applications.

The figure below shows how to wire the controller to an analog potentiometer, an RC radio, the RS232 port, and the Digital output to a motor brake solenoid. You may omit any connection that is not required in your application. The controller automatically arbitrates the command priorities depending on the presence of a valid command signal in the following order: 1-RS232, 2-RC Pulse, 3-None. If needed, use the Roborun+ PC Utility to change the pin assignments and the command priority order.

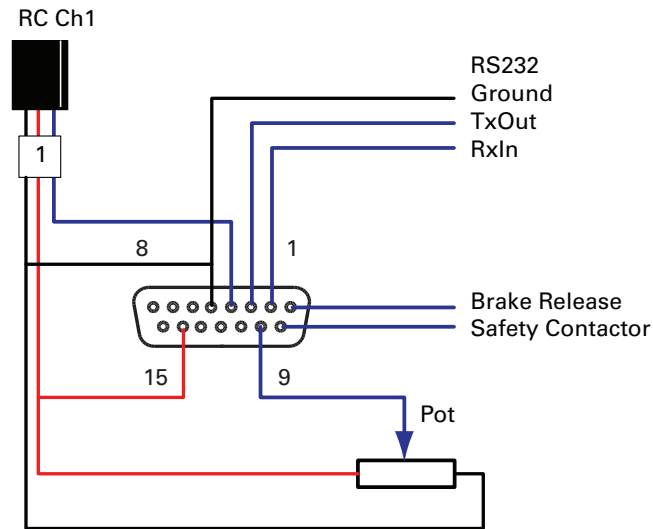

FIGURE 9. Factory default pins assignment

Enabling Analog Commands

For safety reasons, the Analog command mode is disabled by default. To enable the Analog mode, use the PC utility and set Analog in Command Priority 2 or 3 (leave Serial as priority 1). Note that by default the additional securities are enabled and will prevent the motor from starting unless the potentiometer is centered, or if the voltage is below 0.25V or above 4.75V. The drawing shows suggested assignment of Pot 1 to ANA1. Use the PC utility to enable and assign analog inputs.

CAN Bus Operation

The controller can interface to a standard CAN Bus network, using 4 possible protocols: Standard CANOpen, and three proprietary schemes (MiniCAN, RawCAN and RoboCAN). Please refer to the User Manual for details. USB and CAN can operate at the same time only on the MBL1xxxA. On the MBL1xxx, the controller starts up with CAN available, but CAN will be disabled as soon as the controller is plugged into USB. To re-enable CAN, disconnect USB and restart the controller.

USB communication

Use USB only for configuration, monitoring and troubleshooting. USB is not a reliable communication method when used in a electrically noisy environments and communication will not always recover after it is lost without unplugging and replugging the connector, or restarting the controller. Always prefer RS232 communication when interfacing to a computer.

Status LEDs and Flashing Patterns

The controller is equipped with 3 LEDs. A Green Power LED, a Red/Green Status LED (A-version - Red on others), and a Yellow Communication LED.

After the controller is powered on, the Power LED will turn on, indicating that the controller is On. The Status LED will be flashing at a 2 seconds interval. The flashing pattern and color provides operating or exception status information.



FIGURE 10. Normal Operation Flashing Patterns

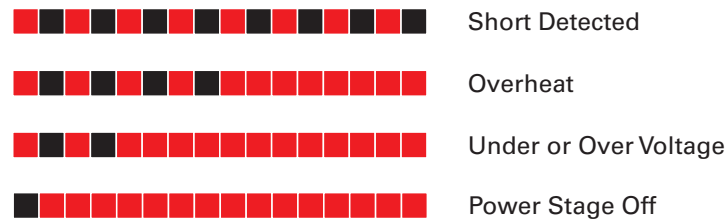

FIGURE 11. Exception or Fault Flashing Patterns

Additional status information may be obtained by monitoring the controller with the PC utility.

The communication LED gives status information on the CAN and USB.

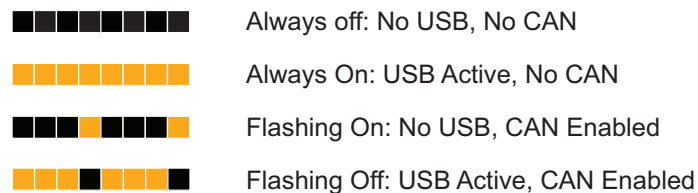

FIGURE 12. Communication LED Flashing Patterns

Electrical Specifications

Absolute Maximum Values

The values in the table below should never be exceeded. Permanent damage to the controller may result.

TABLE 6.

Parameter	Measure point	Model	Min	Typ	Max	Units
Battery Leads Voltage	Ground to VMot	MBL1330			35	Volts
		MBL1660			62	Volts
Reverse Voltage on Battery Leads	Ground to VMot	All	-1			Volts
Power Control Voltage	Ground to Pwr Control wire	All			62	Volts
Motor Leads Voltage	Ground to U, V, W wires	MBL1330			30 (1)	Volts
		MBL1660			62 (1)	Volts
Digital Output Voltage	Ground to Output pins	All			40	Volts
Analog and Digital Inputs Voltage	Ground to any signal pin on 15-pin & Hall inputs	All			15	Volts
RS232 I/O pins Voltage	External voltage applied to Rx/ Tx pins	All			15	Volts
Case Temperature	Case	All	-40		85	oC
Humidity	Case	All			100 (2)	%

Note 1: Maximum regeneration voltage in normal operation. Never inject a DC voltage from a battery or other fixed source
 Note 2: Non-condensing

Power Stage Electrical Specifications (at 25°C ambient)

TABLE 7.

Parameter	Measure point	Model	Min	Typ	Max	Units
Battery Leads Voltage	Ground to VMot	MBL1330	0 (1)		30	Volts
		MBL1660	0 (1)		62	Volts
Motor Leads Voltage	Ground to U, V, W wires	MBL1330	0 (1)		30 (2)	Volts
		MBL1660	0 (1)		62 (2)	Volts
Power Control Voltage		All	0 (1)		65	Volts
Minimum Operating Voltage		All	9 (3)			Volts
Over Voltage protection range	Ground to VMot	MBL1330	5	30 (4)	35	Volts
		MBL1660	5	60 (4)	62	Volts
Under Voltage protection range	Ground to VMot	MBL1330	0	5 (4)	30	Volts
		MBL1660	0	5 (4)	62	Volts
Idle Current Consumption	VMot or Pwr Ctrl wires	All	50	100 (5)	150	mA
ON Resistance (Excluding wire resistance)	VMot to U, V or W. Ground to U, V or W	MBL1330		3		mOhm
		MBL1660		1.5		mOhm

Max Current for 30s	Motor current	MBL1330			75 (6)	Amps
		MBL1660			120 (6)	Amps
Continuous Max Current per channel	Motor current	MBL1330			50 (7)	Amps
		MBL1660			80 (7)	Amps
Current Limit range	Motor current	MBL1330	10	60 (8)	75	Amps
		MBL1660	10	80 (8)	120	Amps
Stall Detection Amps range	Motor current	MBL1330	10	75 (8)	75	Amps
		MBL1660	10	120 (8)	120	Amps
Stall Detection timeout range	Motor current	All	1	65000 (9)	65000	milliseconds
Short Circuit Detection threshold (10)	Between Motor wires or Between Motor wires and Ground	All	200 (11)		500 (11)	Amps
Motor Acceleration/Deceleration range	Motor Output	All	100	500 (12)	65000	milliseconds

Note 1: Negative voltage will cause a large surge current. Protection fuse needed if battery polarity inversion is possible
 Note 2: Maximum regeneration voltage in normal operation. Never inject a DC voltage from a battery or other fixed source
 Note 3: Minimum voltage must be present on VMot or Power Control wire
 Note 4: Factory default value. Adjustable in 0.1V increments
 Note 5: Current consumption is lower when higher voltage is applied to the controller's VMot or PwrCtrl wires
 Note 6: Max value is determined by current limit setting. Duration is estimated and is dependent on ambient temperature cooling condition
 Note 7: Estimate. Limited by heatsink temperature. Current may be higher with better cooling
 Note 8: Factory default value. Adjustable in 0.1A increments
 Note 9: Factory default value. Time in ms that Stall current must be exceeded for detection
 Note 10: Controller will stop until restarted in case of short circuit detection
 Note 11: Sensitivity selectable by software
 Note 12: Factory default value. Time in ms for power to go from 0 to 100%

Command, I/O and Sensor Signals Specifications

TABLE 8.

Parameter	Measure point	Min	Typ	Max	Units
Main 5V Output Voltage	Ground to 5V pin on DSub15	4.7	4.9	5.1	Volts
5V Output Current	5V pin on DSub15			100	mA
Digital Output Voltage	Ground to Output pins			40	Volts
Digital Output Current	Output pins, sink current			1	Amps
Output On resistance	Output pin to ground		0.75	1.5	Ohm
Output Short circuit threshold	Output pin	1.05	1.4	1.75	Amps
Input Impedances	AIN/DIN Input to Ground		53		kOhm
Digital Input 0 Level	Ground to Input pins	-1		1	Volts
Digital Input 1 Level	Ground to Input pins	3		15	Volts
Analog Input Range	Ground to Input pins	0		5.1	Volts

Analog Input Precision	Ground to Input pins		0.5		%
Analog Input Resolution	Ground to Input pins		1		mV
Pulse durations	Pulse inputs	20000		10	us
Pulse repeat rate	Pulse inputs		50	250	Hz
Pulse Capture Resolution	Pulse inputs		1		us
Frequency Capture	Pulse inputs	100		2000	Hz
Encoder count	Internal	-2.147		2.147	10 ⁹ Counts
Encoder frequency	Encoder input pins			1M(1)	Counts/s
Note1: Encoder input requires RC inputs 1 and 2 to be disabled. Encoder is disabled in factory default					

Operating & Timing Specifications

TABLE 9.

Parameter	Measure point	Min	Typ	Max	Units
Command Latency	Command to output change	0	0.5	1	ms
PWM Frequency	Motor outputs	10	18 (1)	20	kHz
Closed Loop update rate	Internal		200	40	Hz
RS232 baud rate	Rx & Tx pins		115200 (2)		Bits/s
RS232 Watchdog timeout	Rx pin	1 (3)		65000	ms
Note 1: May be adjusted with configuration program					
Note 2: 115200, 8-bit, no parity, 1 stop bit, no flow control					
Note 3: May be disabled with value 0					

Scripting

TABLE 10.

Parameter	Measure point	Min	Typ	Max	Units
Scripting Flash Memory	Internal		8192		Bytes
Max Basic Language programs	Internal		1000	1500	Lines
Integer Variables	Internal			1024	Words (1)
Boolean Variables	Internal			1024	Symbols
Execution Speed	Internal	50 000	100 000		Lines/s
Note 1: 32-bit words					

Thermal Specifications

TABLE 11.

Parameter	Measure point	Min	Typ	Max	Units
Board Temperature	PCB	-40		85 (1)	oC

Thermal Protection range	PCB				oC
Thermal resistance	Power MOSFETs to heats sink			2	oC/W
Note 1: Thermal protection will protect the controller power					
Note 2: Max allowed power out starts lowering at minimum of range, down to 0 at max of range					

The MBL1xxx uses a conduction plate at the bottom of the board for heat extraction. For best results, attach firmly with thermal compound paste against a metallic chassis so that heat transfers to the conduction plate to the chassis. If no metallic surface is available, mount the controller on spacers so that forced or natural air flow can go over the plate surface to remove heat.

Mechanical Specifications

TABLE 12.

Parameter	Measure point	Min	Typ	Max	Units
Weight	Board		100 (3.5)		g (oz.)
Power Wire Gauge	FASTON tabs			10	AWG

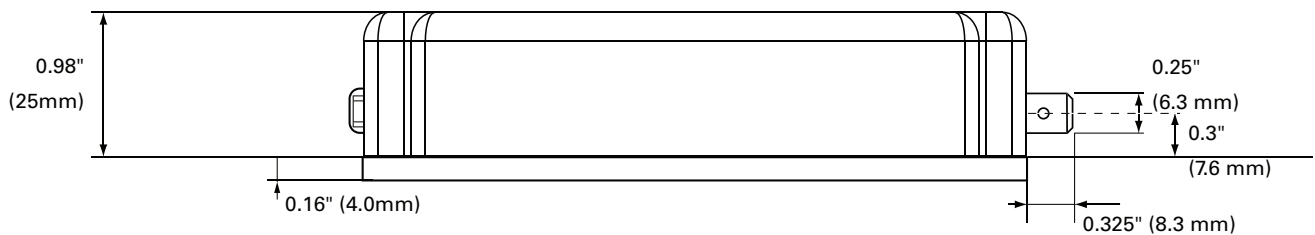

FIGURE 13. MBL1xxx side view and dimensions

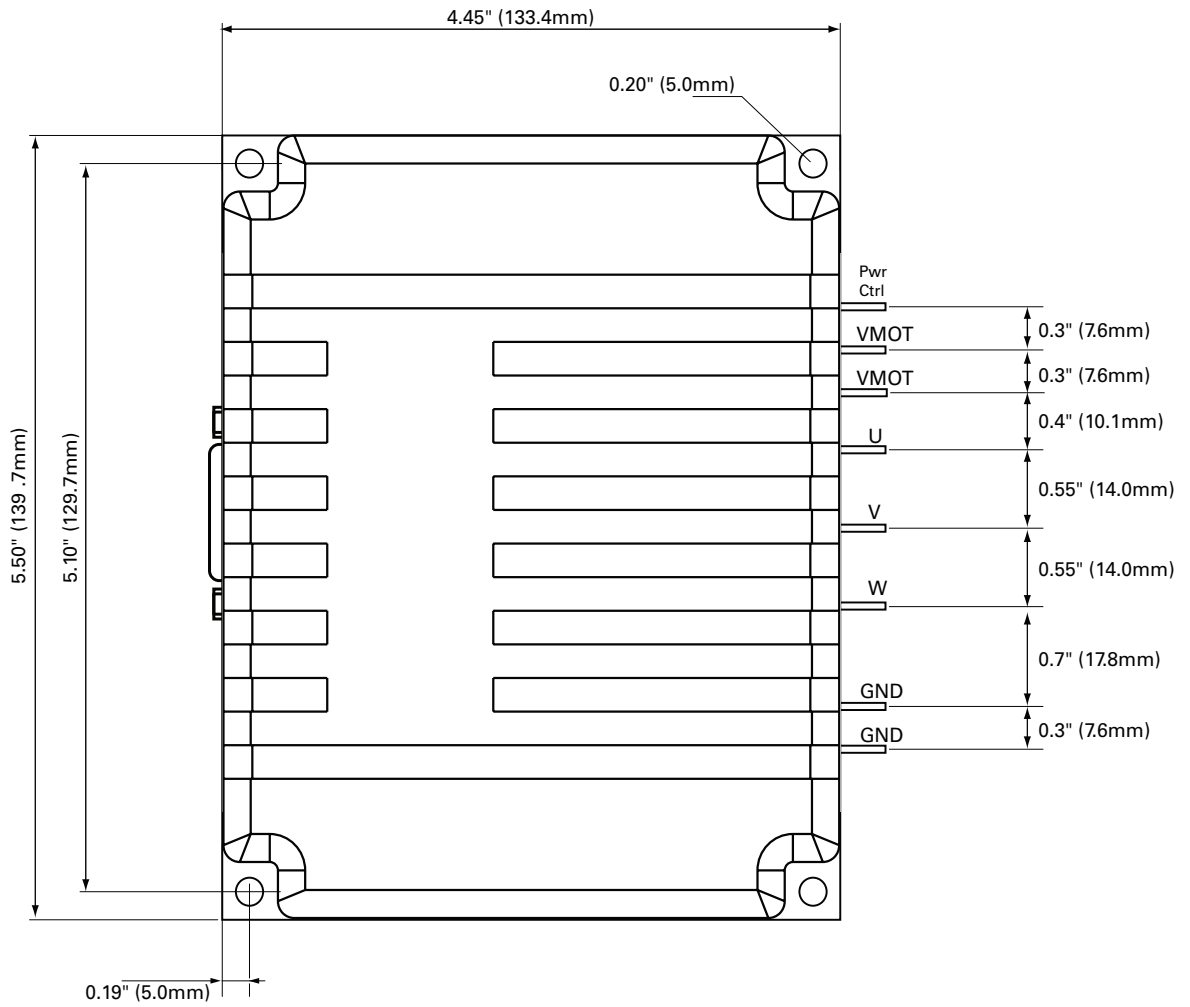

FIGURE 14. MBL1xxx top view and dimensions