

Advanced Digital Motor Controllers

User Manual

**Brushed DC: HDC24xx, VDC24xx, MDC22xx, LDC22xx, LDC14xx,
SDC1130, SDC21xx**

**Brushless DC: HBL16xx, VBL16xx, HBL23xx, VBL23xx, LBL13xx,
MBL16xx, SBL13xx**

Sepex: VSX18xx



v1.3, September 1, 2013

visit www.roboteq.com to download the latest revision of this manual

©Copyright 2013 Roboteq, Inc

Revision History

Date	Version	Changes
September 1, 2013	1.3	Extended command set and CANopen Object Dictionary Implemented FIFO buffer for CAN frames in the RawCAN mode Miscellaneous corrections
May 10, 2012	1.2	Added CAN Networking Added Closed Loop Count Position mode, Closed Loop Torque mode Extended command set
January 8, 2011	1.2	Added Brushless Motor Connections and Operation
July 15, 2010	1.2	Extended command set Improved position mode
May 15, 2010	1.1	Added Scripting
January 1, 2010	1.0	Initial release

The information contained in this manual is believed to be accurate and reliable. However, it may contain errors that were not noticed at time of publication. Users are expected to perform their own product validation and not rely solely on data contained in this manual.

Revision History	2
Introduction	17
Refer to the Datasheet for Hardware-Specific Issues	17
User Manual Structure and Use	17
SECTION 1 Connecting Power and Motors to the Controller	17
SECTION 2 Safety Recommendations	17
SECTION 3 Connecting Sensors and Actuators to Input/Outputs	17
SECTION 4 Command Modes	18
SECTION 5 I/O Configuration and Operation	18
SECTION 6 Motor Operating Features and Options	18
SECTION 7 Brushless Motor Connections and Operation	18
SECTION 8 Closed Loop Speed Mode	18
SECTION 9 Closed Loop Relative and Tracking Position Modes	18
SECTION 10 Closed Loop Count Position Mode	18
SECTION 11 Closed Loop Torque Mode	18
SECTION 12 Serial (RS232/USB) Operation	18
SECTION 13 CAN Networking on Roboteq Controllers	19
SECTION 14 CANopen Interface	19
SECTION 15 MicroBasic Scripting	19
SECTION 16 Commands Reference	19
SECTION 17 Using the Roborun Configuration Utility	19
SECTION 1 Connecting Power and Motors to the Controller	21
Power Connections	21
Controller Power	22
Controller Powering Schemes	24
Mandatory Connections	24
Connection for Safe Operation with Discharged Batteries (note 1)	25
Use precharge Resistor to prevent switch arcing (note 2)	25
Protection against Damage due to Regeneration (notes 3 and 4)	25
Connect Case to Earth if connecting AC equipment (note 5)	25
Avoid Ground loops when connecting I/O devices (note 6)	26
Connecting the Motors	26
Single Channel Operation	27
Power Fuses	27
Wire Length Limits	28
Electrical Noise Reduction Techniques	28
Battery Current vs. Motor Current	28
Power Regeneration Considerations	30
Using the Controller with a Power Supply	30
SECTION 2 Safety Recommendations	33
Possible Failure Causes	33

	Motor Deactivation in Normal Operation	34
	Motor Deactivation in Case of Output Stage Hardware Failure	34
	Manual Emergency Power Disconnect	36
	Remote Emergency Power Disconnect	37
	Protection using Supervisory Microcomputer	37
	Self Protection against Power Stage Failure	38
SECTION 3	Connecting Sensors and Actuators to Input/Outputs	41
	Controller Connections	41
	Controller's Inputs and Outputs	42
	Connecting devices to Digital Outputs	43
	Connecting Resistive Loads to Outputs	43
	Connecting Inductive loads to Outputs	43
	Connecting Switches or Devices to Inputs shared with Outputs	44
	Connecting Switches or Devices to direct Digital Inputs	44
	Connecting a Voltage Source to Analog Inputs	45
	Connecting Potentiometers to Analog Inputs	46
	Connecting Potentiometers for Commands with Safety band guards.	46
	Connecting Tachometer to Analog Inputs	47
	Connecting External Thermistor to Analog Inputs	48
	Using the Analog Inputs to Monitor External Voltages	50
	Connecting Sensors to Pulse Inputs	50
	Connecting to RC Radios.	50
	Connecting to PWM Joysticks and Position Sensors	51
	Connecting Optical Encoders.	51
	Optical Incremental Encoders Overview	51
	Recommended Encoder Types	52
	Connecting the Encoder	53
	Cable Length and Noise Considerations	53
	Motor - Encoder Polarity Matching	54
SECTION 4	Command Modes	55
	Input Command Modes and Priorities	55
	USB vs Serial Communication Arbitration	57
	CAN Commands Arbitration	57
	Commands issued from MicroBasic scripts	57
	Operating the Controller in RC mode.	57
	Input RC Channel Selection	58
	Input RC Channel Configuration	59
	Automatic Joystick Range Calibration	59
	Deadband Insertion	59
	Command Exponentiation	59
	Reception Watchdog	59
	Using Sensors with PWM Outputs for Commands.	60

	Operating the Controller In Analog Mode	60
	Input Analog Channel Selection	60
	Input Analog Channel Configuration	61
	Analog Range Calibration	61
	Using Digital Input for Inverting direction	61
	Safe Start in Analog Mode	61
	Protecting against Loss of Command Device	61
	Safety Switches.	61
	Monitoring and Telemetry in RC or Analog Modes	62
	Using the Controller with a Spektrum Receiver	62
	Using the Controller in Serial (USB/RS232) Mode.	62
SECTION 5	I/O Configuration and Operation	63
	Basic Operation	63
	Input Selection	64
	Digital Inputs Configurations and Uses	64
	Analog Inputs Configurations and Use	65
	Analog Min/Max Detection	66
	Min, Max and Center adjustment	66
	Deadband Selection	67
	Exponent Factor Application	68
	Use of Analog Input	68
	Pulse Inputs Configurations and Uses.	68
	Use of Pulse Input.	69
	Digital Outputs Configurations and Triggers	70
	Encoder Configurations and Use.	70
	Hall Sensor Inputs	71
SECTION 6	Motor Operating Features and Options.	73
	Power Output Circuit Operation	73
	Global Power Configuration Parameters	74
	PWM Frequency	74
	Overvoltage Protection	74
	Undervoltage Protection	74
	Temperature-Based Protection	74
	Short Circuit Protection	75
	Mixing Mode Select	75
	Motor Channel Parameters	76
	User Selected Current Limit Settings	76
	Selectable Amps Threshold Triggering	77
	Programmable Acceleration & Deceleration	77
	Forward and Reverse Output Gain	78
	Selecting the Motor Control Modes	78
	Open Loop Speed Control.	78

	Closed Loop Speed Control	78
	Closed Loop Position Relative Control	78
	Closed Loop Count Position	79
	Closed Loop Tracking	79
	Torque Mode	79
SECTION 7	Brushless Motor Connections and Operation	81
	Brushless Motor Introduction	81
	Number of Poles	82
	Hall Sensor Wiring	82
	Hall Sensor Wiring Order	83
	Brushless Motor Operation	84
	Stall Detection	84
	Speed Measurement using Hall Sensors	85
	Distance Measurement using Hall Sensors	85
SECTION 8	Closed Loop Speed Mode	87
	Mode Description	87
	Tachometer or Encoder Wiring	87
	Tachometer or Encoder Mounting	87
	Tachometer wiring	88
	Brushless Hall Sensors as Speed Sensors	88
	Speed Sensor and Motor Polarity	89
	Controlling Speed in Closed Loop	90
	Control Loop Description	90
	PID tuning in Speed Mode	91
	Error Detection and Protection	92
SECTION 9	Closed Loop Relative and Tracking Position Modes	93
	Modes Description	93
	Position Relative Mode	93
	Position Tracking Mode	93
	Selecting the Position Modes	94
	Position Feedback Sensor Selection	94
	Sensor Mounting	94
	Feedback Sensor Range Setting	95
	Error Detection and Protection	96
	Adding Safety Limit Switches	97
	Using Current Trigger as Protection	98
	Operating in Closed Loop Relative Position Mode	98
	Operating in Closed Loop Tracking Mode	99
	Position Mode Relative Control Loop Description	99
	PID tuning in Position Mode	100

	PID Tuning Differences between Position Relative and Position Tracking . . .	101
SECTION 10	Closed Loop Count Position Mode	103
	Preparing and Switching to Closed Loop.	103
	Count Position Commands	103
	Position Command Chaining	104
	PID Tunings	105
SECTION 11	Closed Loop Torque Mode	107
	Torque Mode Description	107
	Torque Mode Selection, Configuration and Operation	108
	Torque Mode Tuning	108
	Configuring the Loop Error Detection	108
	Torque Mode Limitations.	108
	Torque Mode Using an External Amps Sensor	109
SECTION 12	Serial (RS232/USB) Operation	111
	Use and benefits of Serial Communication	111
	Serial Port Configuration	112
	Connector RS232 Pin Assignment	112
	Cable configuration	112
	Extending the RS232 Cable	113
	USB Configuration.	114
	Command Priorities.	114
	USB vs. Serial Communication Arbitration	114
	CAN Commands	114
	Script-generated Commands	115
	Communication Protocol Description	115
	Character Echo	115
	Command Acknowledgement.	115
	Command Error.	115
	Watchdog time-out	116
	Controller Present Check	116
SECTION 13	CAN Networking on Roboteq Controllers	117
	Supported CAN Modes	117
	Mode Selection and Configuration	117
	Common Configurations	118
	MiniCAN Configurations	118
	RawCAN Configurations	118
	Using RawCAN Mode	118
	Checking Received Frames.	118
	Reading Raw Received Frames.	119

	Transmitting Raw Frames	119
	Using MiniCAN Mode	120
	Transmitting Data.....	120
	Receiving Data.....	121
	MiniCAN Usage Example	121
SECTION 14	CANopen Interface	123
	Use and benefits of CANopen	123
	CAN Connection	124
	CAN Bus Configuration	124
	Node ID	124
	Bit Rate	124
	Heartbeat.....	125
	Autostart	125
	CAN Bus Pinout.....	125
	CAN and USB Limitations	126
	Commands Accessible via CANopen.....	126
	CANopen Message Types	127
	Service Data Object (SDO) Read/Write Messages	127
	Transmit Process Data Object (TPDO) Messages	127
	Receive Process Data Object (RPDO) Messages	128
	Object Dictionary	129
SECTION 15	MicroBasic Scripting	135
	Script Structure and Possibilities	135
	Source Program and Bytecodes	136
	Variables Types and Storage	136
	Variable content after Reset.....	136
	Controller Hardware Read and Write Functions.....	136
	Timers and Wait.....	137
	Execution Time Slot and Execution Speed	137
	Protections.....	137
	Print Command Restrictions	137
	Editing, Building, Simulating and Executing Scripts.....	138
	Editing Scripts	138
	Building Scripts	138
	Simulating Scripts	138
	Downloading MicroBasic Scripts to the controller.....	139
	Executing MicroBasic Scripts	139
	Script Command Priorities	140
	MicroBasic Scripting Techniques	140
	Single Execution Scripts	140
	Continuous Scripts.....	140
	Optimizing Scripts for Integer Math	141
	Script Examples.....	142

MicroBasic Language Reference.....	143
Introduction.....	143
Comments.....	143
Boolean.....	143
Numbers.....	143
Strings.....	144
Blocks and Labels.....	144
Variables.....	145
Arrays.....	145
Terminology.....	145
Keywords.....	146
Operators.....	146
Micro Basic Functions.....	147
Controller Configuration and Commands.....	147
Timers Commands.....	147
Option (Compilation Options).....	147
Dim (Variable Declaration).....	147
If...Then Statement.....	148
For...Next Statement.....	149
While/Do Statements.....	150
Terminate Statement.....	151
Exit Statement.....	151
Continue Statement.....	151
GoTo Statement.....	152
GoSub/Return Statements.....	152
ToBool Statement.....	153
Print Statement.....	153
Abs Function.....	153
+ Operator.....	153
- Operator.....	153
* Operator.....	154
/ Operator.....	154
Mod Operator.....	154
And Operator.....	154
Or Operator.....	154
XOr Operator.....	154
Not Operator.....	154
True Literal.....	155
False Literal.....	155
++ Operator.....	155
-- Operator.....	155
<< Operator.....	156
>> Operator.....	156
<> Operator.....	156
< Operator.....	156
> Operator.....	156
<= Operator.....	156

	> Operator	157
	>= Operator	157
	+= Operator	157
	-= Operator	157
	*= Operator	157
	/= Operator	158
	<<= Operator	158
	>>= Operator	158
	[] Operator	158
	GetValue	158
	SetCommand	160
	SetConfig / GetConfig	161
	SetTimerCount/GetTimerCount	162
	SetTimerState/GetTimerState	162
SECTION 16	Commands Reference	163
	Commands Types	163
	Runtime commands	163
	Runtime queries	163
	Maintenance commands	163
	Set/Read Configuration commands	164
	Runtime Commands	164
	AC - Set Acceleration	165
	AX - Next Acceleration	165
	B - Set User Boolean Variable	165
	BND - Spektrum Radio Bind	166
	C - Set Encoder Counters	166
	CB - Set Brushless Counter	166
	CS - CAN Send	166
	D0 - Reset Individual Digital Out bits	167
	D1 - Set Individual Digital Out bits	167
	DC - Set Deceleration	167
	DS - Set all Digital Out bits	167
	DX - Next Deceleration	168
	EES - Save Configuration in EEPROM	168
	EX - Emergency Stop	168
	G - Go to Speed or to Relative Position	168
	H - Load Home Counter	169
	MG - Emergency Stop Release	169
	MS - Stop in All Modes	169
	P - Go to Absolute Desired Position	169
	PR - Go to Relative Desired Position	170
	PRX - Next Go to Relative Desired Position	170
	PX - Next Go to Absolute Desired Position	170
	R - MicroBasic Run	171
	S - Motor Position-Mode Velocity	171
	SX - Next Velocity	171

VAR - Set User Integer Variable	171
Runtime Queries	172
A - Read Motor Amps	173
AI - Read Analog Input	174
AIC - Read Analog Input after Conversion	174
B - Read User Boolean Variable	174
BA - Read Battery Amps	175
BS - Read BL Motor Speed in RPM	175
BSR - Read BL Motor Speed as 1/1000 of Max	175
C - Read Encoder Counter Absolute	176
CAN - Read Raw CAN frame	176
CB - Read Absolute Brushless Counter	176
CBR - Read Brushless Count Relative	177
CF - Read Raw CAN Received Frames Count	177
CIA - Read Internal Analog Command	177
CIP - Read Internal Pulse Command	177
CIS - Read Internal Serial Command	178
CR - Read Encoder Counter Relative	178
D - Read Digital Inputs	178
DI - Read Individual Digital Inputs	178
DO - Read Digital Output Status	179
DR - Read Destination Reached	179
E - Read Closed Loop Error	179
F - Read Feedback In	180
FF - Read Fault Flag	180
FID - Read Firmware ID	180
FM - Read Runtime Status Flag	180
FS - Read Status Flag	181
K - Read Spektrum Receiver	181
LK - Read Lock Status	182
M - Read Motor Command Applied	182
MA - Read MEMS Accelerometers	182
MGD - Read Magsensor Track Detect	183
MGM - Read Magsensor Markers	183
MGS - Read Magsensor Status	183
MGT - Read Magsensor Track Position	183
P - Read Motor Power Output Applied	184
PI - Read Pulse Input	184
PIC - Read Pulse Input after Conversion	184
S - Read Encoder Speed RPM	185
SR - Read Encoder Speed Relative	185
T - Read Temperature	185
TM - Read Time	185
TR - Read Position Relative Tracking	186
TRN - Read Control Unit type and Controller Model	186
V - Read Volts	186
VAR - Read User Integer Variable	187

Query History Commands	188
# - Send Next History Item / Stop Automatic Sending	188
# C - Clear Buffer History	188
# nn - Start Automatic Sending	189
Maintenance Commands	190
BIND - Bind Spektrum Receiver	190
DFU - Update Firmware via USB	190
EELD - Load Parameters from EEPROM	191
EERST - Reset Factory Defaults	191
EESAV - Save Configuration in EEPROM	191
LK - Lock Configuration Access	191
RESET - Reset Controller	192
STIME - Set Time	192
UK - Unlock Configuration Access	192
Flash Card Maintenance Commands	193
SDIR - List Files Stored on Card	193
SREAD - Read the Content of a File	193
SDEL - Delete File	193
Set/Read Configuration Commands	194
Setting Configurations	194
Reading Configurations	194
Configuration Read Protection	195
Command Inputs Configuration and Safety	195
ACS - Analog Center Safety	196
AMS - Analog within Min & Max Safety	196
BRUN - MicroBasic Auto Start	196
CLIN - Command Linearity	196
CPRI - Command Priorities	197
DFC - Default Command value	197
ECHOE - Enable/Disable Serial Echo	198
RWD - Serial Data Watchdog	198
TELS - Telemetry String	198
Digital Input/Output Configurations	199
DINA - Digital Input Action	199
DINL - Digital Input Active Level	200
DOA - Digital Output Action	200
DOL - Digital Outputs Active Level	200
Analog Input Configurations	201
ACTR - Set Analog Input Center (0) Level	201
ADB - Analog Deadband	201
AINA - Analog Input Usage	202
ALIN - Analog Linearity	202
AMAX - Set Analog Input Max Range	203
AMAXA - Action at Analog Max	203
AMIN - Set Analog Input Min Range	203
AMINA - Action at Analog Min	204

AMOD - Enable and Set Analog Input Mode	204
APOL - Analog Input Polarity	204
Pulse Input Configuration	205
PCTR - Pulse Center Range	205
PDB - Pulse Input Deadband	205
PINA - Pulse Input Use	206
PLIN - Pulse Linearity	206
PMAX - Pulse Max Range	206
PMAXA - Action at Pulse Max	207
PMIN - Pulse Min Range	207
PMINA - Action at Pulse Min	207
PMOD - Pulse Mode Select	207
PPOL - Pulse Input Polarity	208
Encoder Operations	208
EHL - Encoder High Count Limit	208
EHLA - Encoder High Limit Action	209
EHOME - Encoder Counter Load at Home Position	209
ELL - Encoder Low Count Limit	209
ELLA - Encoder Low Limit Action	209
EMOD - Encoder Usage	210
EPPR - Encoder PPR Value	210
Brushless Specific Commands	211
BHL - Brushless Counter High Limit	211
BHLA - Brushless Counter High Limit Action	211
BHOME - Brushless Counter Load at Home Position	211
BLFB - Encoder or Hall Sensor Feedback	212
BLL - Brushless Counter Low Limit	212
BLLA - Brushless Counter Low Limit Action	212
BLSTD - Brushless Stall Detection	213
BPOL - Number of Poles of Brushless Motor and Speed Polarity	213
General Power Stage Configuration Commands	214
BKD - Brake Activation Delay	214
MXMD - Separate or Mixed Mode Select	214
OVL - Overvoltage Limit	214
PWMF - PWM Frequency	215
THLD - Short Circuit Detection Threshold	215
UVL - Undervoltage Limit	215
Motor Channel Configuration and Set Points	216
ALIM - Amp Limit	216
ATGA - Amps Trigger Action	217
ATGD - Amps Trigger Delay	217
ATRIG - Amps Trigger Level	217
CLERD - Closed Loop Error Detection	218
ICAP - PID Integral Cap	218
KD - PID Differential Gain	218
KI - PID Integral Gain	219

	KP - PID Proportional Gain	219
	MAC - Motor Acceleration Rate	219
	MDEC - Motor Deceleration Rate	220
	MMOD - Operating Mode	220
	MVEL - Default Position Velocity	220
	MXPF - Motor Max Power Forward	220
	MXPR - Motor Max Power Reverse	221
	MXRPM - Max RPM Value	221
	MXTRN - Turns between Limits	221
	Sepex Specific Commands	222
	SXC - Sepex Motor Excitation Table	222
	SXM - Sepex Minimum Excitation Current	222
	CAN Specific Commands	223
	CTPS - CANOpen TPDO Send Rate	223
SECTION 17	Using the Roborun Configuration Utility	225
	System Requirements	225
	Downloading and Installing the Utility	225
	The Roborun+ Interface	226
	Header Content	227
	Status Bar Content	227
	Program Launch and Controller Discovery	228
	Configuration Tab	229
	Entering Parameter Values	230
	Automatic Analog and Pulse input Calibration	230
	Input/Output Labeling	231
	Loading, Saving Controller Parameters	232
	Locking & Unlocking Configuration Access	232
	Configuration Parameters Grouping & Organization	233
	Commands Parameters	233
	Encoder Parameters	234
	Digital Input and Output Parameters	235
	Analog Input Parameters	235
	Pulse Input Parameters	235
	Power Settings	235
	Run Tab	237
	Status and Fault Monitoring	237
	Applying Motor Commands	238
	Digital, Analog and Pulse Input Monitoring	238
	Digital Output Activation and Monitoring	238
	Using the Chart Recorder	238
	Console Tab	240
	Text-Mode Commands Communication	240
	Updating the Controller's Firmware	241
	Updating the Controller Logic	241

Scripting Tab	243
Edit Window	243
Download to Device button.....	243
Build button.....	243
Simulation button	244
Executing Scripts	244

Introduction

Refer to the Datasheet for Hardware-Specific Issues

This manual is the companion to your controller's datasheet. All information that is specific to a particular controller model is found in the datasheet. These include:

- Number and types of I/O
- Connectors pin-out
- Wiring diagrams
- Maximum voltage and operating voltage
- Thermal and environmental specifications
- Mechanical drawings and characteristics

User Manual Structure and Use

The user manual discusses issues that are common to all controllers inside a given product family. Except for a few exceptions, the information contained in the manual does not repeat the data that is provided in the datasheets.

The manual is divided in 17 sections organized as follows:

SECTION 1 Connecting Power and Motors to the Controller

This section describes the power connections to the battery and motors, the mandatory vs. optional connections. Instructions and recommendations are provided for safe operation under all conditions.

SECTION 2 Safety Recommendations

This section lists the possible motor failure causes and provides examples of prevention methods and possible ways to regain control over motor if such failures occur.

SECTION 3 Connecting Sensors and Actuators to Input/Outputs

This section describes all the types of inputs that are available on all controller models and describes how to attach sensors and actuators to them. This section also describes the connection and operation of optical encoders.

SECTION 4 Command Modes

The controller can be operated using serial, analog or pulse commands. This section describes each of these modes and how the controller can switch from one command input to another. Detailed descriptions are provided for the RC pulse and Analog command modes and all their configurable options.

SECTION 5 I/O Configuration and Operation

This section details the possible use of each type of Digital, Analog, Pulse or Encoder inputs, and the Digital Outputs available on the controller. It describes in detail the software configurable options available for each I/O type.

SECTION 6 Motor Operating Features and Options

This section reviews all the configurable options available to the motor driver section. It covers global parameters such as PWM frequency, overvoltage, or temperature-based protection, as well as motor channel-specific configurations. These include amps limiting, acceleration/deceleration settings, or operating modes.

SECTION 7 Brushless Motor Connections and Operation

This section addresses installation and operating issues specific to brushless motors. It is applicable only to brushless motor controller models.

SECTION 8 Closed Loop Speed Mode

This section focuses on the closed loop speed mode with feedback using analog speed sensors or encoders. Information is provided on how to setup a closed loop speed control system, tune the PID control loop, and operate the controller.

SECTION 9 Closed Loop Relative and Tracking Position Modes

This section describes how to configure and operate the controller in position mode using analog, pulse, or encoder feedback. In position mode, the motor can be made to smoothly go from one position to the next. Information is provided on how to setup a closed loop position system, tune the PID control loop, and operate the controller.

SECTION 10 Closed Loop Count Position Mode

This section describes how to configure and operate the controller in Closed Loop Count Position mode. Position command chaining is provided to ensure seamless motor motion.

SECTION 11 Closed Loop Torque Mode

This section describes how to select, configure and operate the controller in Closed Loop Torque mode.

SECTION 12 Serial (RS232/USB) Operation

This section describes how to communicate to the controller via the RS232 or USB interface.

SECTION 13 CAN Networking on Roboteq Controllers

This section describes the RawCAN and MiniCAN operating modes available on CAN-enabled Roboteq controllers.

SECTION 14 CANopen Interface

This section describes the configuration of the CANopen communication protocol and the commands accepted by the controller operating in the CANopen mode.

SECTION 15 MicroBasic Scripting

This section describes the MicroBasic scripting language that is built into the controller. It describes the features and capabilities of the language and how to write custom scripts. A Language Reference is provided.

SECTION 16 Commands Reference

This section lists and describes in detail all configuration parameters, runtime commands, operating queries, and maintenance commands available in the controller.

SECTION 17 Using the Roborun Configuration Utility

This section describes the features and capabilities of the Roborun PC utility. The utility can be used for setting/changing configurations, operate/monitor the motors and I/O, edit, simulate and run Microbasic scripts, and perform various maintenance functions such as firmware updates.

SECTION 1

Connecting Power and Motors to the Controller

This section describes the controller's connections to power sources and motors.

This section does not show connector pin-outs or wiring diagram. Refer to the datasheet for these.

Important Warning

The controller is a high power electronics device. Serious damage, including fire, may occur to the unit, motor, wiring and batteries as a result of its misuse. Please follow the instructions in this section very carefully. Any problem due to wiring errors may have very serious consequences and will not be covered by the product's warranty.

Power Connections

Power connections are described in the controller model's datasheet. Depending on the model type, power connection is done via wires, fast-on tabs, screw terminals or copper bars coming out of the controller.

Controllers with wires as power connections have Ground (black), VMot (red) power cables and a Power Control wire (yellow). The power cables are located at the back end of the controller. The various power cables are identified by their position, wire thickness and color: red is positive (+), black is negative or ground (-).

Controllers with tabs, screw terminals or copper bars have their connector identified in print on the controller.

Controller Power

The controller uses a flexible power supply scheme that is best described in Figure 1. In this diagram, it can be seen that the power for the Controller's internal microcomputer is separate from this of the motor drivers. The microcomputer circuit is connected to a DC/DC converter which takes power from either the Power Control input or the VMot input. A diode circuit that is included in most controller models, is designed to automatically select one power source over the other and lets through the source that has the highest voltage.

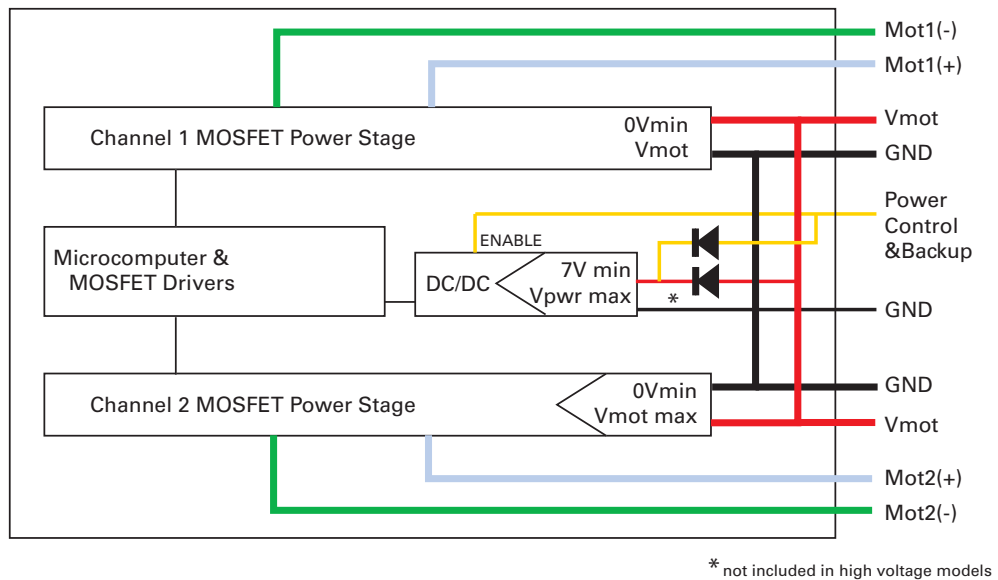

FIGURE 1. Representation of the controller's Internal Power Circuits

When powered via the Power Control input only, the controller will turn On, but motors will not be able to turn until power is also present on the VMot wires or Tab.

The Power Control input also serves as the Enable signal for the DC/DC converter. When floating or pulled to above 1V, the DC/DC converter is active and supplies the controller's microcomputer and drivers, thus turning it On. When the Power Control input is pulled to Ground, the DC/DC converter is stopped and the controller is turned Off.

The Power Control input **MUST** be connected to Ground to turn the Controller Off. For turning the controller On, even though the Power Control may be left floating, whenever possible pull it to a 12V or higher voltage to keep the controller logic solidly On. You may use a separate battery to keep the controller alive as the main Motor battery discharges.

The diode that is used to bring power from the main battery is excluded in some high voltage controller models. For these controllers, a separate voltage source must be provided externally to the Power Control input.

The table below shows the state of the controller depending on the voltage applied to Power Control and VMot.

TABLE 1. Controller Status depending on Power Control and VMot

Power Control input is connected to	And Main Battery Voltage is	Action
Ground	Any Voltage	Controller is Off. Required Off Configuration.
Floating	0V	Controller is Off. Not Recommended Off Configuration.
Floating (1)	Between 7 and VMotMax (See VMotMax value in datasheet)	Controller is On. Power Stage is Active
7V to max Volts	Below undervoltage threshold	Controller is On. Power Stage is Off
7V to max Volts	Between undervoltage and overvoltage limits	Controller is On. Power Stage is Active
Note1: High voltage controllers are off if Power Control is not connected to a power source.		

Note: All 3 ground (-) are connected to each other inside the controller. The two VMot main battery wires are also connected to each other internally. However, you must never assume that connecting one wire of a given battery potential will eliminate the need to connect the other.

Controller Powering Schemes

Roboteq controllers operate in an environment where high currents may circulate in unexpected manners under certain condition. Please follow these instructions. Roboteq reserves the right to void product warranty if analysis determines that damage is due to improper controller power connection.

The example diagram on Figure 2 shows how to wire the controller and how to turn power On and Off. All Roboteq models use a similar power circuit. See the controller datasheet for the exact wiring diagram for your controller model.

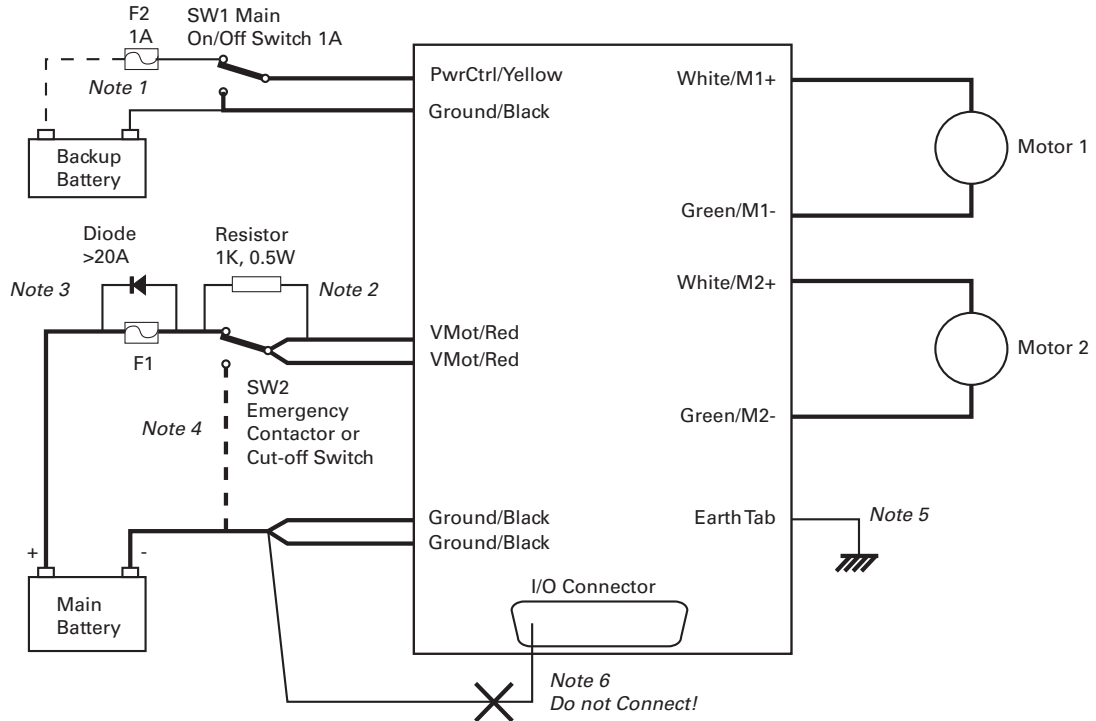

FIGURE 2. Brushed DC controller powering diagram

Mandatory Connections

It is imperative that the controller is connected as shown in the wiring diagram provided in the datasheet in order to ensure a safe and trouble-free operation. All connections shown as thick black lines are mandatory.

- Connect the thick black wire(s) or the ground terminal to the minus (-) terminal of the battery that will be used to power the motors. Connect the thick red wire(s) or VMot terminal to the plus (+) terminal of the battery. The motor battery may be of 12V up to the maximum voltage specified in the controller model datasheet.
- The controller must be powered On/Off using switch SW1 on the Power Control wire/terminal. Grounding this line powers Off the controller. Floating or pulling this line to a voltage will power On the controller. (SW1 is a common SPDT 1 Amp or more switch).
- Use a suitable high-current fuse F1 as a safety measure to prevent damage to the wiring in case of major controller malfunction. (Littlefuse ATO or MAXI series).

- The battery must be connected in permanence to the controller's Red wire(s) or VMot terminal via a high-power emergency switch SW2 as additional safety measure. Partially discharged batteries may not blow the fuse, while still having enough power left to cause a fire. Leave the switch SW2 closed at all times and open only in case of an emergency. Use the main On/Off switch SW1 for normal operation. This will prolong the life of SW2, which is subject to arcing when opening under high current with consequent danger of contact welding.
- If installing in an electric vehicle equipped with a Key Switch where SW2 is a contactor, and the key switch energizes the SW2 coil, then implement SW1 as a relay. Connect the Key Switch to both coils of SW1 and SW2 so cutting off the power to the vehicle by the key switch and SW2 will set the main switch SW1 in the OFF position as well.

Connection for Safe Operation with Discharged Batteries (note 1)

The controller will stop functioning when the main battery voltage drops below 7V. To ensure motor operation with weak or discharged batteries, connect a second battery to the Power Control wire/terminal via the SW1 switch. This battery will only power the controller's internal logic. The motors will continue to be powered by the main battery while the main battery voltage is higher than the secondary battery voltage. This option is valid on all controller models except the SDCxxxx.

Use precharge Resistor to prevent switch arcing (note 2)

Insert a 1K, 0.5W resistor across the SW2 Emergency Switch. This will cause the controller's internal capacitors to slowly charge and maintain the full battery voltage by the time the SW2 switch is turned on and thus eliminate damaging arcing to take place inside the switch. Make sure that the controller is turned Off with the Power Control wire grounded while the SW2 switch is off. The controller's capacitors will not charge if the Power Control wire is left floating and arcing will then occur when the Emergency switch is turned on.

Protection against Damage due to Regeneration (notes 3 and 4)

Voltage generated by motors rotating while not powered by the controller can cause serious damage even if the controller is Off or disconnected. This protection is highly recommended in any application where high motion inertia exists or when motors can be made to rotate by towing or pushing (vehicle parking).

- Use the main SW1 switch on the Power Control wire/terminal to turn Off and keep Off the controller.
- Insert a high-current diode (Digikey P/N 10A01CT-ND) to ensure a return path to the battery in case the fuse is blown. Smaller diodes are acceptable as long as their single pulse current rating is > 20 Amp.
- Optionally use a Single Pole, Dual Throw switch for SW2 to ground the controller power input when OFF. If a SPDT switch cannot be used, then consider extending the diode across the fuse and the switch SW2.

Connect Case to Earth if connecting AC equipment (note 5)

If building a system which uses rechargeable batteries, it must be assumed that periodically a user will connect an AC battery charger to the system. Being connected to the AC main, the charger may accidentally bring AC high voltage to the system's chassis and to the controller's enclosure. Similar danger exists when the controller is powered via a power supply connected to the mains.

The controllers are supplied with an Earth tab, which permits earthing the metal case. Connect this tab to a wire connected to the Earth while the charger is plugged in the AC main, or if the controller is powered by an AC power supply or is being repaired using any other AC equipment (PC, Voltmeter etc.)

Avoid Ground loops when connecting I/O devices (note 6)

When connecting a PC, encoder, switch or actuators on the I/O connector, be very careful that you do not create a path from the ground pins on the I/O connector and the battery minus terminal. Should the controller's main Ground wires (thick black) be disconnected while the VMot wires (thick red) are connected, high current would flow from the ground pins, potentially causing serious damage to the controller and/or your external devices.

- Do not connect a wire between the I/O connector ground pins and the battery minus terminal. Look for hidden connection and eliminate them.
- Have a very firm and secure connection of the controller ground wire and the battery minus terminal.
- Do not use connectors or switches on the power ground cables.

Important Warning

Do not rely on cutting power to the controller for it to turn Off if the Power Control is left floating. If motors are spinning because the robot is pushed or because of inertia, they will act as generators and will turn the controller On, possibly in an unsafe state. ALWAYS ground the Power Control wire terminal to turn the controller Off and keep it Off.

Important Warning

Unless you can ensure a steady voltage that is higher than 7V in all conditions, it is recommended that the battery used to power the controller's electronics be separate from the one used to power the motors. This is because it is very likely that the motor batteries will be subject to very large current loads which may cause the voltage to eventually dip below 7V as the batteries' charge drops. The separate backup power supply should be connected to the Power Control input. This warning applies to all controllers except the SDCxxxx models.

Connecting the Motors

Refer to the datasheet for information on how to wire the motor(s) to a particular motor controller model.

After connecting the motors, apply a minimal amount of power using the Roborun PC utility with the controller configured in **Open Loop speed mode**. Verify that the motor spins in the desired direction. Immediately stop and swap the motor wires if not.

In Closed Loop Speed or Position mode, beware that the motor polarity must match this of the feedback. If it does not, the motors will runaway with no possibility to stop other than switching Off the power. The polarity of the Motor or of the feedback device may need to be changed.

Important Warning

Make sure that your motors have their wires isolated from the motor casing. Some motors, particularly automotive parts, use only one wire, with the other connected to the motor's frame.

If you are using this type of motor, make sure that it is mounted on isolators and that its casing will not cause a short circuit with other motors and circuits which may also be inadvertently connected to the same metal chassis.

Single Channel Operation

Dual channel Brushed DC controllers may be ordered with the -S (Single Channel) suffix.

The two channel outputs must be paralleled as shown in the datasheet so that they can drive a single load with twice the power. To perform in this manner, the controller's Power Transistors that are switching in each channel must be perfectly synchronized. Without this synchronization, the current will flow from one channel to the other and cause the destruction of the controller.

The single channel version of the controller incorporates a hardware setting inside the controller which ensures that both channels switch in a synchronized manner and respond to commands sent to channel 1.

Important Warning

Before pairing the outputs, attach the motor to one channel and then the other. Verify that the motor responds the same way to command changes.

Power Fuses

For low Amperage applications (below 30A per motor), it is recommended that a fuse be inserted in series with the main battery circuit as shown above and in the Figure 2 on page 24.

The fuse will be shared by the two output stages and therefore must be placed before the Y connection to the two power wires. Fuse rating should be the sum of the expected current on both channels. Note that automotive fuses above 40A are generally slow, will be of limited effectiveness in protecting the controller and may be omitted in high current application. The fuse will mostly protect the wiring and battery against after the controller has failed.

Important Warning

Fuses are typically slow to blow and will thus allow temporary excess current to flow through them for a time (the higher the excess current, the faster the fuse will blow). This characteristic is desirable in most cases, as it will allow motors to draw surges during acceleration and braking. However, it also means that the fuse may not be able to protect the controller.

Wire Length Limits

The controller regulates the output power by switching the power to the motors On and Off at high frequencies. At such frequencies, the wires' inductance produces undesirable effects such as parasitic RF emissions, ringing and overvoltage peaks. The controller has built-in capacitors and voltage limiters that will reduce these effects. However, should the wire inductance be increased, for example by extended wire length, these effects will be amplified beyond the controller's capability to correct them. This is particularly the case for the main battery power wires.

Important Warning

Avoid long connection between the controller and power source, as the added inductance may cause damage to the controller when operating at high currents. Try extending the motor wires instead since the added inductance is not harmful on this side of the controller.

If the controller must be located at a long distance from the power source, the effects of the wire inductance may be reduced by using one or more of the following techniques:

- Twisting the power and ground wires over the full length of the wires
- Use the vehicle's metallic chassis for ground and run the positive wire along the surface
- Add a capacitor (10,000uF or higher) near the controller

Electrical Noise Reduction Techniques

As discussed in the above section, the controller uses fast switching technology to control the amount of power applied to the motors. While the controller incorporates several circuits to keep electrical noise to a minimum, additional techniques can be used to keep the noise low when installing the controller in an application. Below is a list of techniques you can try to keep noise emission low:

- Keep wires as short as possible
- Loop wires through ferrite cores
- Add snubber RC circuit at motor terminals
- Keep controller, wires and battery enclosed in metallic body

Battery Current vs. Motor Current

The controller measures and limits the current that flows through the motors and not the battery current. Current that flows through the motor is typically higher than the battery current. This counter-intuitive phenomenon is due to the "flyback" current in the motor's inductance. In some cases, the motor current can be extremely high, causing heat and potentially damage while battery current appears low or reasonable.

The motor's power is controlled by varying the On/Off duty cycle of the battery voltage 16,000 times per second to the motor from 0% (motor off) to 100 (motor on). Because of the inductive flyback effect, during the Off time current continues to flow at nearly the same peak - and not the average - level as during the On time. At low PWM ratios, the

peak current - and therefore motor current - can be very high as shown in Figure 4, "Instant and average current waveforms," on page 29.

The relation between Battery Current and Motor current is given in the formula below:

$$\text{Motor Current} = \text{Battery Current} / \text{PWM ratio}$$

Example: If the controller reports 10A of battery current while at 10% PWM, the current in the motor is $10 / 0.1 = 100\text{A}$.

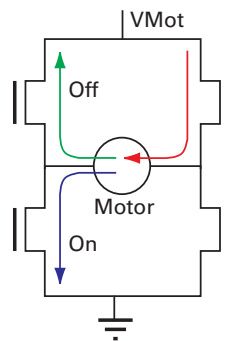

FIGURE 3. Current flow during operation

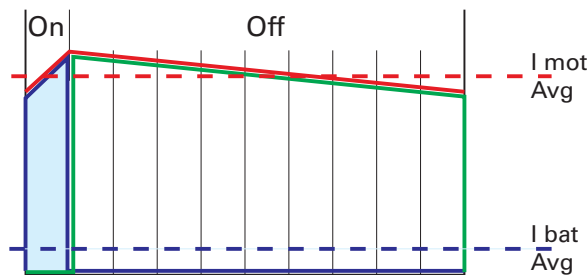

FIGURE 4. Instant and average current waveforms

The relation between Battery Current and Motor current is given in the formula below:

$$\text{Motor Current} = \text{Battery Current} / \text{PWM Ratio}$$

Example: If the controller reports 10A of battery current while at 10% PWM, the current in the motor is $10 / 0.1 = 100\text{A}$.

Important Warning

Do not connect a motor that is rated at a higher current than the controller.

Power Regeneration Considerations

When a motor is spinning faster than it would normally at the applied voltage, such as when moving downhill or decelerating, the motor acts like a generator. In such cases, the current will flow in the opposite direction, back to the power source.

It is therefore essential that the controller be connected to rechargeable batteries. If a power supply is used instead, the current will attempt to flow back in the power supply during regeneration, potentially damaging it and/or the controller.

Regeneration can also cause potential problems if the battery is disconnected while the motors are still spinning. In such a case, the energy generated by the motor will keep the controller On, and depending on the command level applied at that time, the regenerated current will attempt to flow back to the battery. Since none is present, the voltage will rise to potentially unsafe levels. The controller includes an overvoltage protection circuit to prevent damage to the output transistors (see “Using the Controller with a Power Supply” on page 30). However, if there is a possibility that the motor could be made to spin and generate a voltage higher than 40V, a path to the battery must be provided, even after a fuse is blown. This can be accomplished by inserting a diode across the fuse as shown in Figure 2 on page 24.

Please download the Application Note “Understanding Regeneration” from the www.roboteq.com for an in-depth discussion of this complex but important topic.

Important Warning

Use the controller only with a rechargeable battery as supply to the Motor Power wires (thick black and red wires). If a transformer or power supply is used, damage to the controller and/or power supply may occur during regeneration. See “Using the Controller with a Power Supply” on page 30 for details.

Important Warning

Avoid switching Off or cutting open the main power cables while the motors are spinning. Damage to the controller may occur. Always ground the Power Control wire to turn the controller Off.

Using the Controller with a Power Supply

Using a transformer or a switching power supply is possible but requires special care, as the current will want to flow back from the motors to the power supply during regeneration. As discussed in “Power Regeneration Considerations” on page 30, if the supply is not able to absorb and dissipate regenerated current, the voltage will increase until the overvoltage protection circuit cuts off the motors. While this process should not be harmful to the controller, it may be to the power supply, unless one or more of the protective steps below is taken:

- Use a power supply that will not suffer damage in case a voltage is applied at its output that is higher than its own output voltage. This information is seldom published in commercial power supplies, so it is not always possible to obtain positive reassurance that the supply will survive such a condition.

- Avoid deceleration that is quicker than the natural deceleration due to the friction in the motor assembly (motor, gears, load). Any deceleration that would be quicker than natural friction means that braking energy will need to be taken out of the system, causing a reverse current flow and voltage rise. See “Important Warning” on page 77.
- Place a battery in parallel with the power supply output. This will provide a reservoir into which regeneration current can flow. It will also be very helpful for delivering high current surges during motor acceleration, making it possible to use a lower current power supply. Batteries mounted in this way should be connected for the first time only while fully charged and should not be allowed to discharge. The power supply will be required to output unsafe amounts of current if connected directly to a discharged battery. Consider using a decoupling diode on the power supply’s output to prevent battery or regeneration current to flow back into the power supply.
- Place a resistive load in parallel with the power supply, with a circuit to enable that load during regeneration. This solution is more complex but will provide a safe path for the braking energy into a load designed to dissipate it. To prevent current from flowing from the power supply into the load during normal operation, an active switch would enable the load when the voltage rises above the nominal output of the power supply. The controller can be configured to activate the load using a digital output configured to turn on when overvoltage condition is detected.

SECTION 2

Safety

Recommendations

In many applications, Roboteq controllers drive high power motors that move parts and equipment at high speed and/or with very high force. In case of malfunction, potentially enormous forces can be applied at the wrong time and/or wrong place causing serious damage to property and/or harm to person. While Roboteq controllers operate very reliably, and failures are rare, a failure is possible as with any other electronic equipment. If there is any danger that a loss of motor control can cause damage or injury, you must plan on that possibility and implement methods for stopping the motor **independently of the controller operation**.

Below is a list of failure categories, their effect and possible ways to regain control, or minimize the consequences. The list of possible failures is not exhaustive and the suggested prevention methods are provided as examples for information only.

Important Safety Disclaimer

Dangerous uncontrolled motor runaway condition can occur for a number of reasons, including, but not limited to: command or feedback wiring failure, configuration error, faulty firmware, errors in user MicroBasic script or in user program, or controller hardware failure. The user must assume that such failures can occur and must take all measures necessary to make his/her system safe in all conditions.

The information contained in this manual, and in this section in particular, is provided for information only. Roboteq will not be liable in case of damage or injury as a result of product misuse or failure.

Possible Failure Causes

Dangerous unintended motor operation could occur for a number of reasons, including, but not limited to:

- Failure in Command device
- Feedback sensors malfunction
- Wiring errors or failure

- Controller configuration error
- Faulty firmware
- Errors or oversights in user MicroBasic scripts
- Controller hardware failure

Motor Deactivation in Normal Operation

In normal operation, the controller is always able to turn off the motor if it detects faults or if instructed to do so from an external command.

In case of wiring problem, sensor malfunction, firmware failure or error in user Microbasic scripts, the controller may be in a situation where the motors are turned on and kept on as long as the controller is powered. A number of features discussed throughout this manual are available to stop motor operation in case of abnormal situation. These include:

- Watchdog on missing incoming serial/USB commands
- Loss detection of Radio Pulse
- Analog command outside valid range
- Limit switches
- Stall detection
- Close Loop error detection
- Other ...

Additional features can easily be added using MicroBasic scripting.

Ultimately, the controller can be simply turned off by grounding the Power Control pin. Assuming there is no hardware damage in the power stage, the controller output will be off (i.e. motor wires floating) when the controller is off.

Important Warning:

While cutting the power to the motors is generally the best thing to do in case of major failure, it may not necessarily result in a safe situation.

Motor Deactivation in Case of Output Stage Hardware Failure

On brushed DC motor controllers, the power stage for each motor is composed of 4 MOSFETs (semiconductor switches). In some case of failures to MOSFETs in the power stage, it is possible that one or both motors will remain permanently powered with no way to stop them either via software or by turning the controller off.

On brushless motor controllers, shorted MOSFETs will not cause the motor to turn on its own. Nevertheless, it is still advised to follow the recommendations included in this section.

The figures below show all the possible combinations of shorted MOSFETs switches.

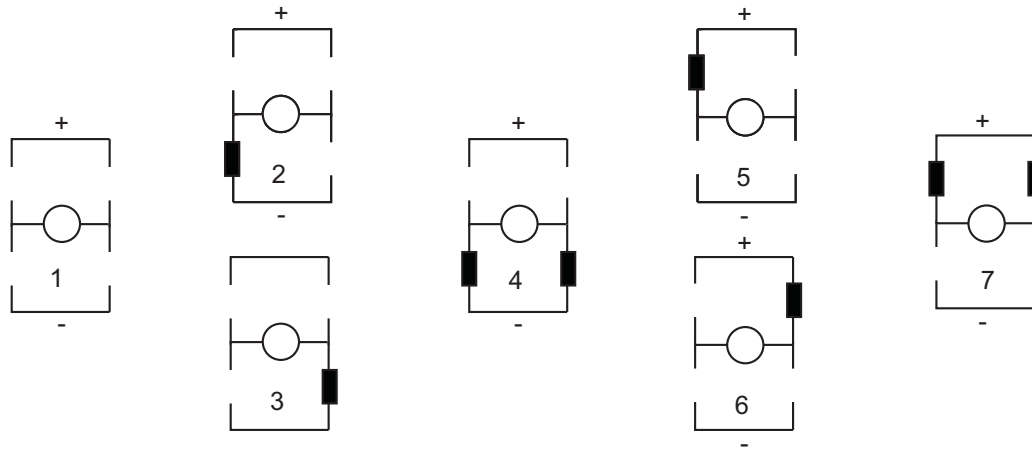

FIGURE 5. MOSFET Failures resulting in no motor activation

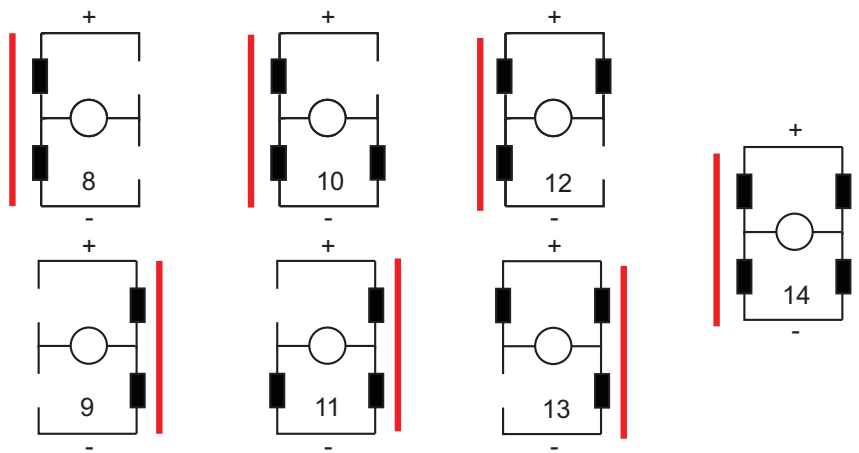

FIGURE 6. MOSFET Failures resulting in battery short circuit and no motor activation

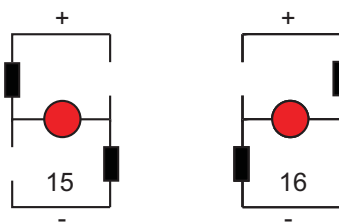

FIGURE 7. MOSFET Failures resulting in motor activation

Two failure conditions (15 and 16) will result in the motor spinning out of control regardless whether the controller is on or off. While these failure conditions are rare, users must take them into account and provide means to cut all power to the controller's power stage.

Manual Emergency Power Disconnect

In systems where the operator is within physical reach of the controller, the simplest safety device is the emergency disconnect switch that is shown in the wiring diagram inside all controller datasheets, and in the example diagram below.

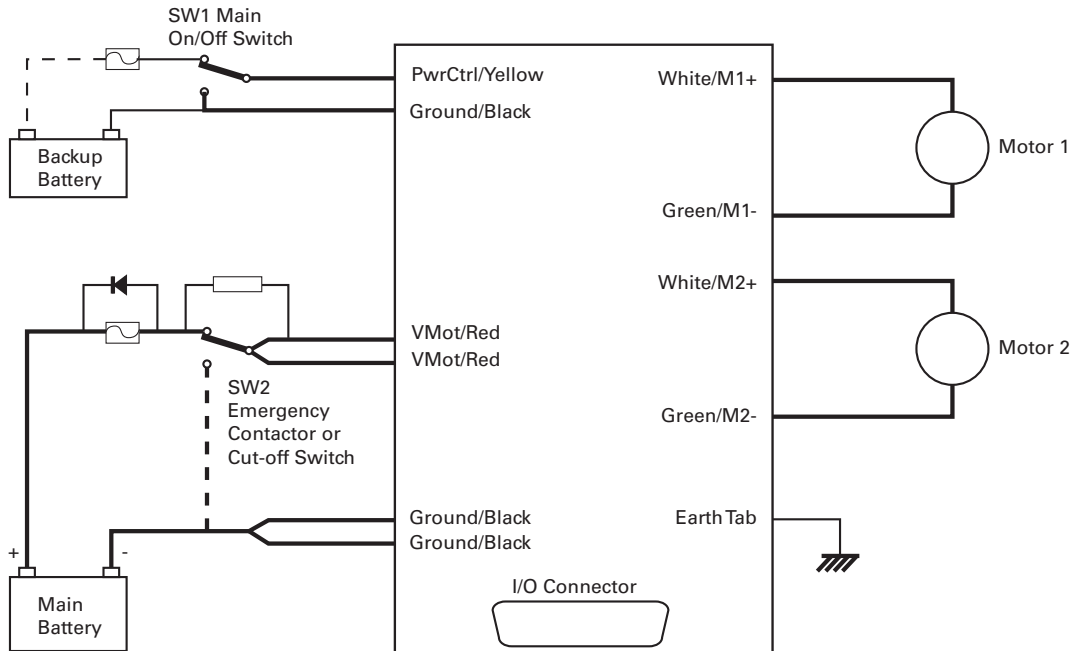

FIGURE 8. Example powering diagram (Brushed DC motor controller)

The switch must be placed visibly and be easy to operate. Prefer "mushroom" emergency stop push buttons. Make sure that the switches are rated at the maximum current that can be expected to flow through all motors at the same time.



FIGURE 9. "Mushroom" type Emergency Disconnect Switch

Remote Emergency Power Disconnect

In remote controlled systems, the emergency switch must be replaced by a high power contactor relay as shown in Figure 10. The relay must be normally open and be activated using an RC switch on a separate radio channel. The receiver should preferably be powered directly from the system's battery. If powered from the controller's 5V output, keep in mind that in case of a total failure of the controller, the 5V output may or may not be interrupted.

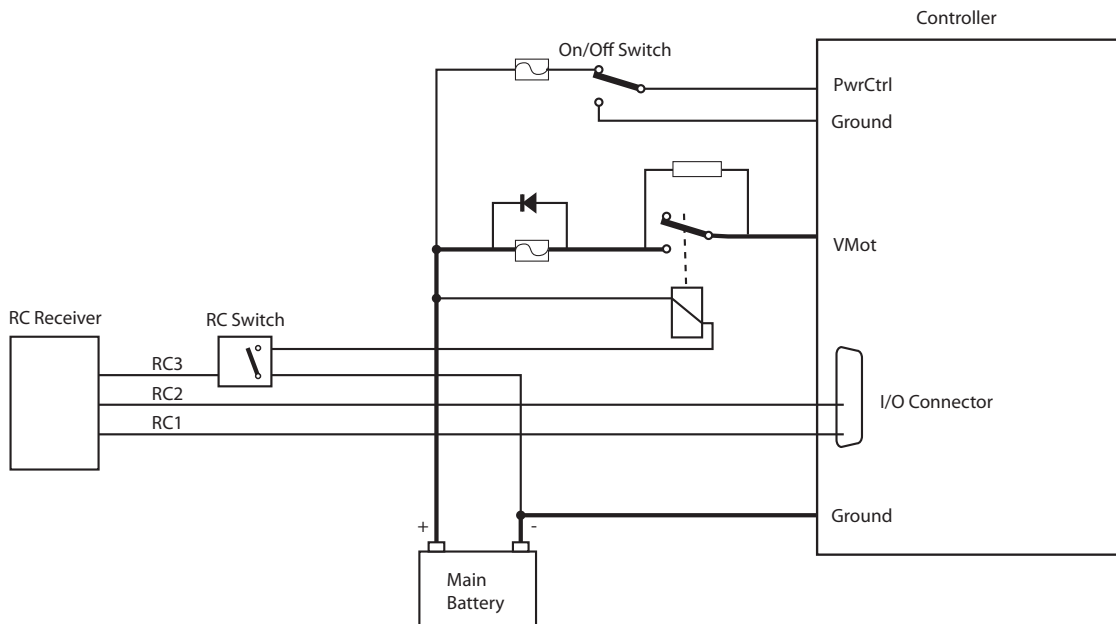

FIGURE 10. Example of remotely operated safety disconnect

The receiver must operate in such a way that the contactor relay will be off if the transmitter is off or out of range.

The transmitter should have a visible and easy to reach emergency switch for the operator. That switch will be used to deactivate the relay remotely. It could also be used to shut-down entirely the transmitter, assuming it is determined for certain that this will deactivate the relay at the controller.

Protection using Supervisory Microcomputer

In applications where the controller is commanded by a PC, a microcomputer or a PLC, that supervisory system could be used to verify that the controller is still responding and cut the power to the controller's power stage in case a malfunction is detected. The supervisory system would only require a digital output or other means to activate/deactivate the contactor relay as shown in the figure below.

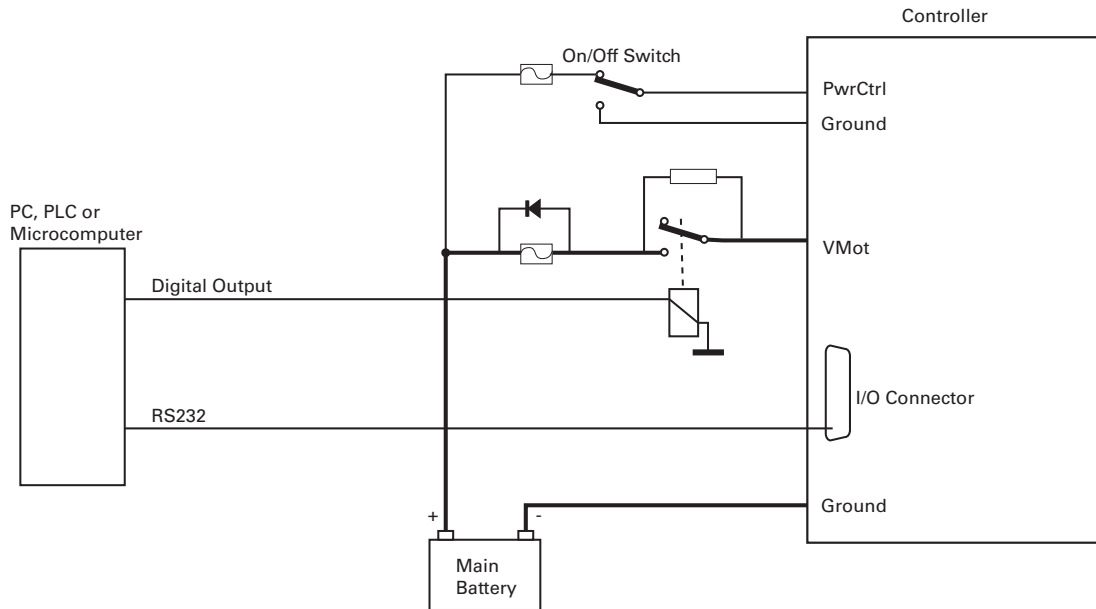

FIGURE 11. Example of safety disconnect via supervisory system

Self Protection against Power Stage Failure

If the controller processor is still operational, it can self detect several, although not all, situations where a motor is running while the power stage is off. The figure below shows a protection circuit using an external contactor relay.

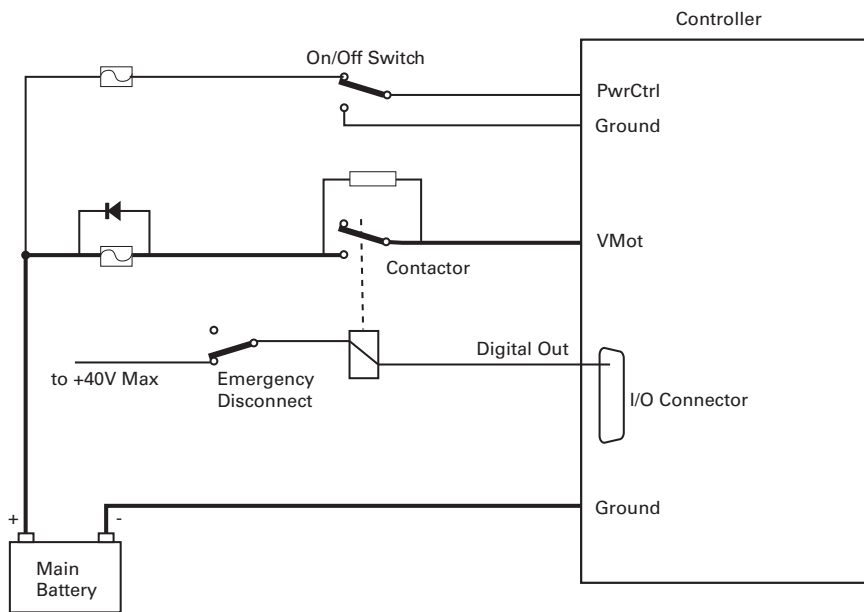

FIGURE 12. Self-protection circuit using contactor

The controller must have the Power Control input wired to the battery so that it can operate and communicate independently of the power stage. The controller's processor will then activate the contactor coil through a digital output configured to turn on when the "No MOSFET Failure" condition is true. The controller will automatically deactivate the coil if the output is expected to be off and battery current is above 500mA to 2.5A (depending on the controller model) for more than 0.5s.

The contactor must be rated high enough so that it can cut the full load current. For even higher safety, additional precaution should be taken to prevent and to detect fused contactor blades.

This contactor circuit will only detect and protect against damaged output stage conditions. It will not protect against all other types of fault. Notice therefore, the presence of an emergency switch in series with the contactor coil. This switch should be operated manually or remotely, as discussed in the "Manual Emergency Power Disconnect" on page 36, the "Remote Emergency Power Disconnect" on page 37 and the "Protection using Supervisory Microcomputer" on page 37.

Using this contactor circuit, turning off the controller will normally deactivate the digital output and this will cut the power to the controller's output stage.

Important Warning

Fully autonomous and unsupervised systems cannot depend on electronics alone to ensure absolute safety. While a number of techniques can be used to improve safety, they will minimize but never totally eliminate risks. Such systems must be mechanically designed so that no moving parts can ever cause harm in any circumstances.

SECTION 3

Connecting Sensors and Actuators to Input/Outputs

This section describes the various inputs and outputs and provides guidance on how to connect sensors, actuators or other accessories to them.

Controller Connections

The controller uses a set of power connections (located on the back of the unit) and, on the front, and DSub connectors for all necessary connections.

The power connections are used for connection to the batteries and motor, and will typically carry large current loads. Details on the controller's power wiring can be found at "Connecting Power and Motors to the Controller" on page 21.

The DSub connectors are used for all low-voltage, low-current connections to the Radio, Microcontroller, sensors and accessories. This section covers only the connections to sensors and actuators.

For information on how to connect the RS232 port, see "Serial (RS232/USB) Operation" on page 111.

The remainder of this section describes how to connect sensors and actuators to the controller's low-voltage I/O pins that are located on the DSub connectors.

Controller's Inputs and Outputs

The controller includes several inputs and outputs for various sensors and actuators. Depending on the selected operating mode, some of these I/Os provide command, feedback and/or safety information to the controller.

When the controller operates in modes that do not use these I/Os, these signals are ignored or can become available via the USB/RS232 port for user application. Below is a summary of the available signals and the modes in which they are used by the controller. The actual number of signal of each type, voltage or current specification, and their position on the I/O connector is given in the controller datasheet.

TABLE 2. Controller's IO signals and definitions

Signal	I/O type	Use/Activation
DOUT1 to DOUTn	Digital Output	<ul style="list-style-type: none"> - Activated when motor(s) is powered - Activated when motor(s) is reversed - Activated when overvoltage - Mirror Status LED - Deactivates when output stage fault - User activated (RS232/USB)
DIN1 to DINn	Digital Input	<ul style="list-style-type: none"> - Safety Stop - Emergency stop - Motor Stop (deadman switch) - Invert motor direction - Forward or reverse limit switch - Run MicroBasic Script - Load Home counter
AIN1 to AINn	Analog Input	<ul style="list-style-type: none"> - Command for motor(s) - Speed or position feedback - Trigger Action similar to Digital Input if under or over user-selectable threshold
PIN1 to PINn	Pulse Input	<ul style="list-style-type: none"> - Command for motor(s) - Speed or position feedback - Trigger Action similar to Digital Input if under or over user-selectable threshold
ENC1a/b to ENC2a/b	Encoder Inputs	<ul style="list-style-type: none"> - Command for motor(s) - Speed or position feedback - Trigger action similar to Digital Input if under or over user-selectable count threshold

Connecting devices to Digital Outputs

Depending on the controller model, 2 to 8 Digital Outputs are available for multiple purposes. The Outputs are Open Drain MOSFET outputs capable of driving over 1A at up to 24V. See datasheet for detailed specifications.

Since the outputs are Open Drain, the output will be pulled to ground when activated. The load must therefore be connected to the output at one end and to a positive voltage source (e.g. a 24V battery) at the other.

Connecting Resistive Loads to Outputs

Resistive or other non-inductive loads can be connected simply as shown in the diagram below.

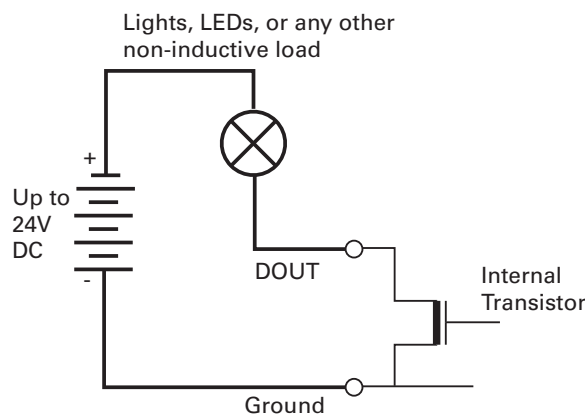

FIGURE 13. Connecting resistive loads to DOUT pins

Connecting Inductive loads to Outputs

The diagrams on Figure 14 show how to connect a relay, solenoid, valve, small motor, or other inductive load to a Digital Output:

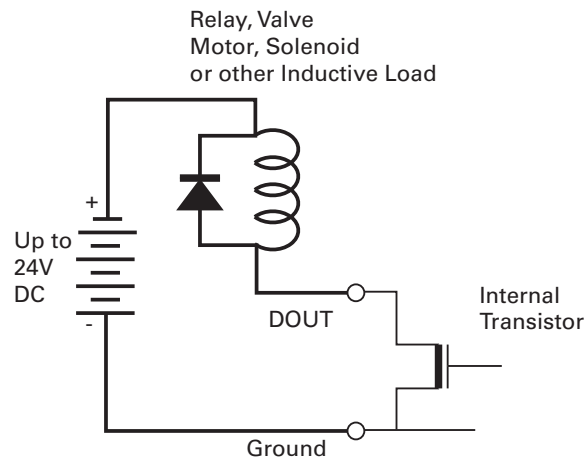

FIGURE 14. Connecting inductive loads to DOUT pins

Important Warning

Overvoltage spikes induced by switching inductive loads, such as solenoids or relays, will destroy the transistor unless a protection diode is used.

Connecting Switches or Devices to Inputs shared with Outputs

On HDCxxx and HBLxxx controllers, Digital inputs DIN12 to DIN19 share the connector pins with digital outputs DOUT1 to DOUT8. When the digital outputs are in the Off state, these outputs can be used as inputs to read the presence or absence of a voltage at these pins.

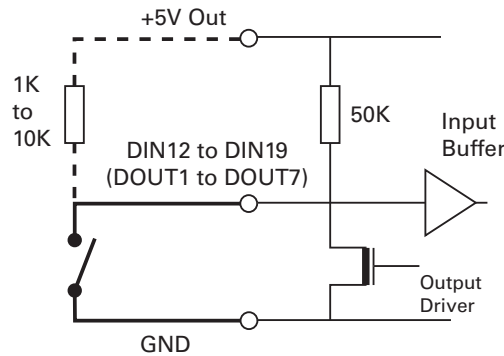

FIGURE 15. Switch wiring to Inputs shared with Outputs

For better noise immunity, an external pull up resistor should be installed even though one is already present inside the controller.

Connecting Switches or Devices to direct Digital Inputs

The controller Digital Inputs are high impedance lines with a pull down resistor built into the controller. Therefore it will report an On state if unconnected, and a simple switch as shown on Figure 16 is necessary to activate it. When a pull up switch is used, for better noise immunity, an external pull down resistor should be installed even though one is already present inside the controller.

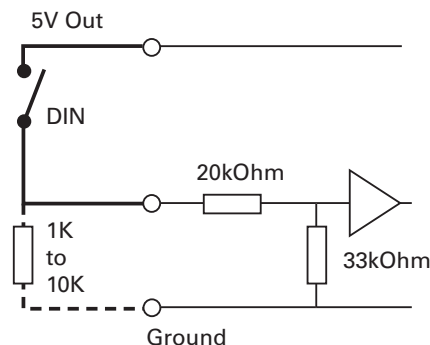

FIGURE 16. Pull up switch wirings to DIN pins

A pull up resistor must be installed when using a pull down switch.

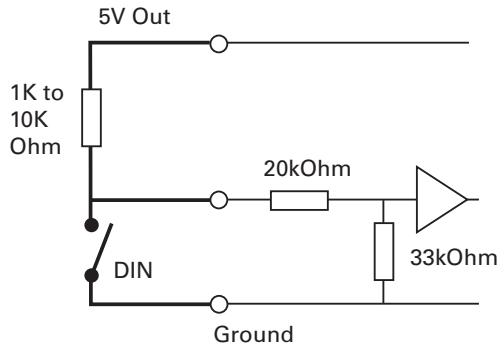

FIGURE 17. Pull down switch wirings to DIN pins

Important Warning

Do not activate an output when it is used as input. If the input is connected directly to a positive voltage when the output is activated, a short circuit will occur. Always pull the input up via a resistor.

Connecting a Voltage Source to Analog Inputs

Connecting sensors with variable voltage output to the controller is simply done by making a direct connection to the controller's analog inputs. When measuring absolute voltages, configure the input in "Absolute Mode" using the PC Utility. See also "ACTR - Set Analog Input Center (0) Level" on page 201.

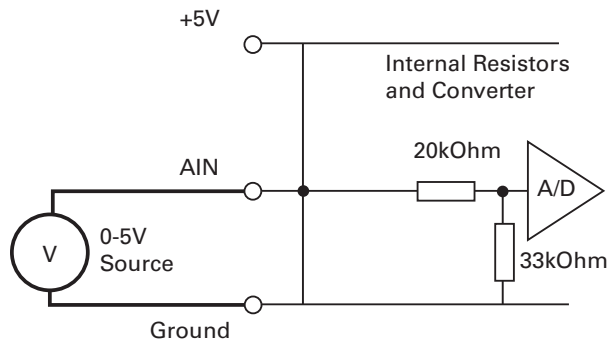

FIGURE 18. Voltage source connected to Analog inputs

Connecting Potentiometers to Analog Inputs

Potentiometers mounted on a foot pedal or inside a joystick are an effective method for giving command to the controller. In closed loop mode, a potentiometer is typically used to provide position feedback information to the controller.

Connecting the potentiometer to the controller is as simple as shown in the diagram on Figure 19.

The potentiometer value is limited at the low end by the current that will flow through it and which should ideally not exceed 5 or 10mA. If the potentiometer value is too high, the analog voltage at the pot's middle point will be distorted by the input's resistance to ground of 53K. A high value potentiometer also makes the input sensitive to noise, particularly if wiring is long. Potentiometers of 1K or 5K are recommended values.

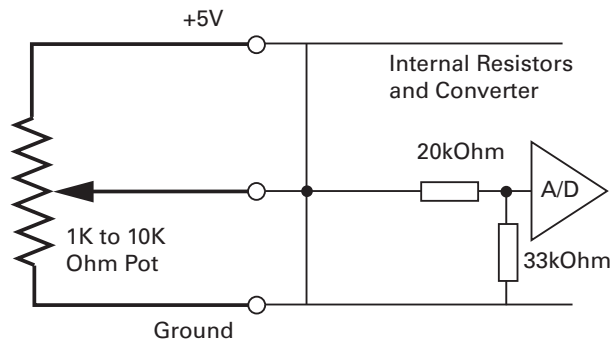

FIGURE 19. Potentiometer wiring in Position mode

Because the voltage at the potentiometer output is related to the actual voltage at the controller's 5V output, configure the analog input in "Relative Mode". This mode measures the actual voltage at the 5V output in order to eliminate any imprecision due to source voltage variations. Configure using the PC Utility or see "ACTR - Set Analog Input Center (0) Level" on page 201.

Connecting Potentiometers for Commands with Safety band guards

When a potentiometer is used for sensing a critical command (Speed or Brake, for example) it is critically important that the controller reverts to a safe condition in case wiring is sectioned. This can be done by adding resistors at each end of the potentiometer so that the full 0V or the full 5V will never be present, during normal operation, when the potentiometer is moved end to end.

Using this circuit shown below, the Analog input will be pulled to 0V if the two top wires of the pot are cut, and pulled to 5V if the bottom wire is cut. In normal operation, using the shown resistor values, the analog voltage at the input will vary from 0.2V to 4.8V.

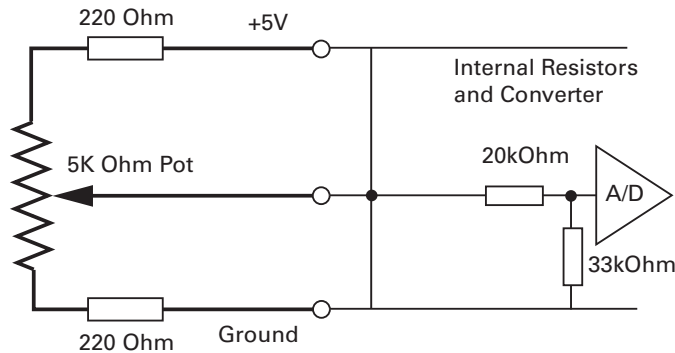

FIGURE 20. Potentiometer wiring in Position mode

The controller's analog channels are configured by default so that the min and max command range is from 0.25V to 4.75V. These values can be changed using the PC configuration utility. This ensures that the full travel of the pot is used to generate a command that spans from full min to full max.

If the Min/Max safety is enabled for the selected analog input, the command will be considered invalid if the voltage is lower than 0.1V or higher than 4.9. These values cannot be changed.

Connecting Tachometer to Analog Inputs

When operating in closed loop speed mode, tachometers can be connected to the controller to report the measured motor speed. The tachometer can be a good quality brushed DC motor used as a generator. The tachometer shaft must be directly tied to that of the motor with the least possible slack.

Since the controller only accepts a 0 to 5V positive voltage as its input, the circuit shown in Figure 21 must be used between the controller and the tachometer: a 10kOhm potentiometer is used to scale the tachometer output voltage to -2.5V (max reverse speed) and +2.5V (max forward speed). The two 1kOhm resistors form a voltage divider that sets the idle voltage at mid-point (2.5V), which is interpreted as the zero position by the controller.

With this circuitry, the controller will see 2.5V at its input when the tachometer is stopped, 0V when running in full reverse, and +5V in full forward.

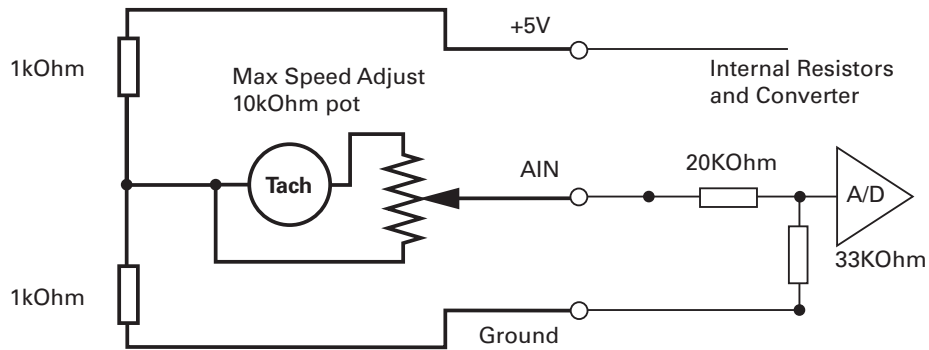

FIGURE 21. Tachometer wiring diagram

The tachometers can generate voltages in excess of 2.5 volts at full speed. It is important, therefore, to set the potentiometer to the minimum value (cursor all the way down per this drawing) during the first installation.

Since in closed loop control the measured speed is the basis for the controller’s power output (i.e. deliver more power if slower than desired speed, less if higher), an adjustment and calibration phase is necessary. This procedure is described in “Closed Loop Speed Mode” on page 87.

Important Warning

The tachometer’s polarity must be such that a positive voltage is generated to the controller’s input when the motor is rotating in the forward direction. If the polarity is inverted, this will cause the motor to run away to the maximum speed as soon as the controller is powered and eventually trigger the closed loop error and stop. If this protection is disabled, there will be no way of stopping it other than pressing the emergency stop button or disconnecting the power.

Connecting External Thermistor to Analog Inputs

Using external thermistors, the controller can be made to supervise the motor’s temperature and cut the power output in case of overheating. Connecting thermistors is done according to the diagram shown in Figure 22. Use a 10kOhm Negative Coefficient Thermistor (NTC) with the temperature/resistance characteristics shown in the table below. Recommended part is Vishay NTCLE100E3103JB0, Digikey item BC2301-ND.

TABLE 3. Recommended NTC characteristics

Temp (oC)	-25	0	25	50	75	100
Resistance (kOhm)	129	32.5	10.00	3.60	1.48	0.67

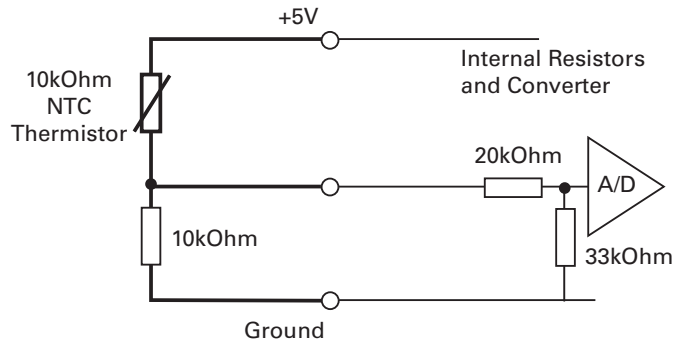

FIGURE 22. NTC Thermistor wiring diagram

Thermistors are non-linear devices. Using the circuit described on Figure 22, the controller will read the following values according to the temperature. For best precision, the analog input must be configured to read in Relative Mode.

The analog input must be configured so that the minimum range voltage matches the desired temperature and that an action be triggered when that limit is reached. For example 500mV for 80°C, according to the table. The action can be any of the actions in the list. An emergency or safety stop (i.e. stop power until operator moves command to 0) would be a typical action to trigger.

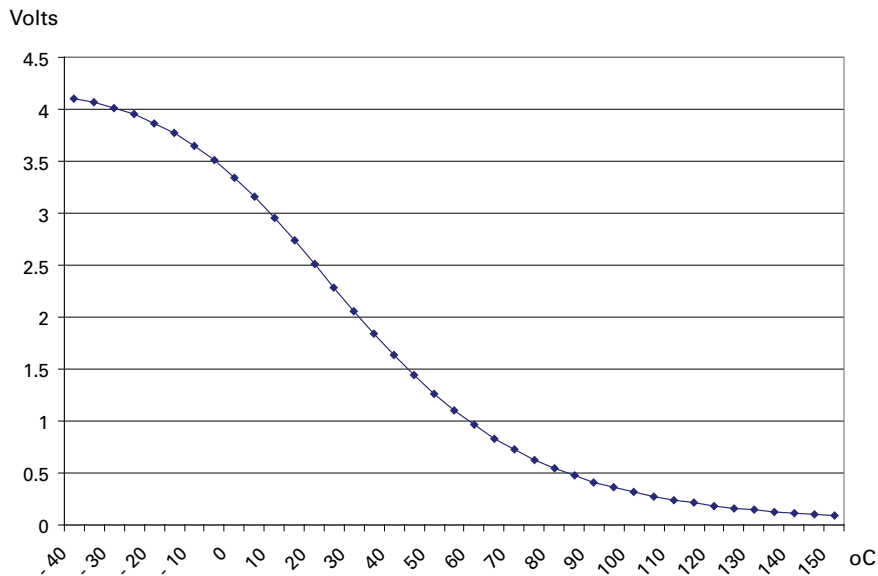

FIGURE 23. Voltage reading by controller vs. NTC temperature

Note: The voltage values in this chart are provided for reference only and may vary based on the Thermistor model/brand and the resistor precision. It is recommended that you verify and calibrate your circuit if it is to be used for safety protection.

Using the Analog Inputs to Monitor External Voltages

The analog inputs may also be used to monitor the battery level or any other DC voltage. If the voltage to measure is up to 5V, the voltage can be brought directly to the input pin. To measure higher voltage, insert two resistors wired as voltage divider. The figure shows a 10x divider capable of measuring voltages up to 50V.

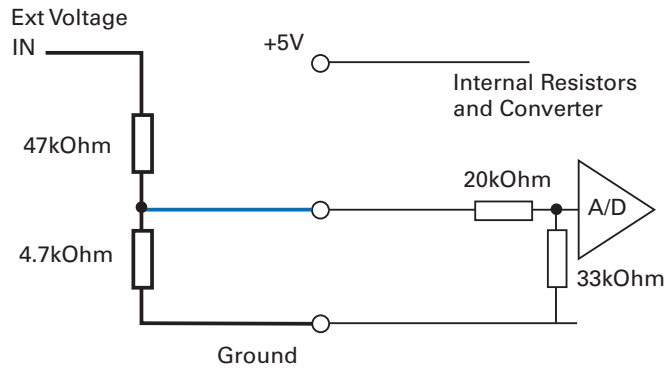

FIGURE 24. Battery voltage monitoring circuit

Connecting Sensors to Pulse Inputs

The controller has several pulse inputs capable of capturing Pulse Length, Duty Cycle or Frequency with excellent precision. Being a digital signal, pulses are also immune to noise compared to analog inputs.

Connecting to RC Radios

The pulse inputs are designed to allow direct connection to an RC radio without additional components.

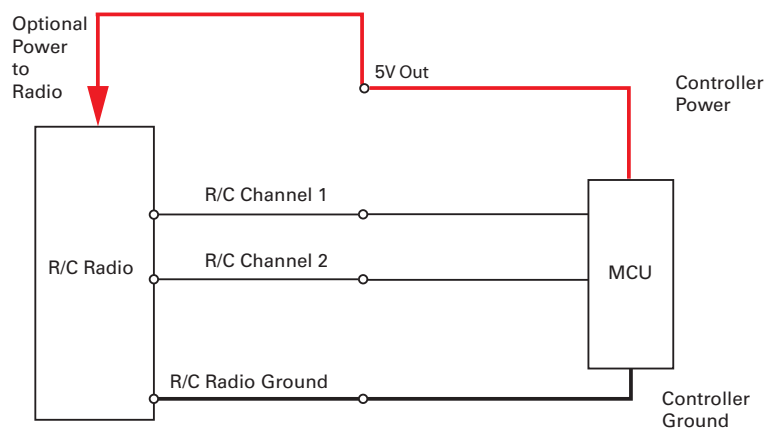

FIGURE 25. RC Radio powered by controller electrical diagram

Connecting to PWM Joysticks and Position Sensors

The controller’s pulse inputs can also be used to connect to sensors with PWM outputs. These sensors provide excellent noise immunity and precision. When using PWM sensors, configure the pulse input in Duty Cycle mode. Beware that the sensor should always be pulsing and never output a steady DC voltage at its ends. The absence of pulses is considered by the controller as a loss of signal. See also “Using Sensors with PWM Outputs for Commands” on page 60.

Connecting Optical Encoders

Optical Incremental Encoders Overview

Optical incremental encoders are a means for capturing speed and travelled distance on a motor. Unlike absolute encoders which give out a multi-bit number (depending on the resolution), incremental encoders output pulses as they rotate. Counting the pulses tells the application how many revolutions, or fractions of, the motor has turned. Rotation velocity can be determined from the time interval between pulses or by the number of pulses within a given time period. Because they are digital devices, incremental encoders will measure distance and speed with perfect accuracy.

Since motors can move in forward and reverse directions, it is necessary to differentiate the manner that pulses are counted so that they can increment or decrement a position counter in the application. Quadrature encoders have dual channels, A and B, which are electrically phased 90° apart. Thus, direction of rotation can be determined by monitoring the phase relationship between the two channels. In addition, with a dual-channel encoder, a four-time multiplication of resolution is achieved by counting the rising and falling edges of each channel (A and B). For example, an encoder that produces 250 Pulses per Revolution (PPR) can generate 1,000 Counts per Revolution (CPR) after quadrature.

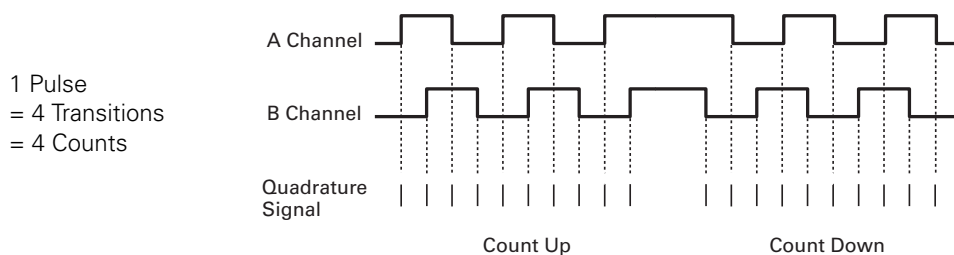

FIGURE 26. Quadrature encoder output waveform

The figure below shows the typical construction of a quadrature encoder. As the disk rotates in front of the stationary mask, it shutters light from the LED. The light that passes through the mask is received by the photo detectors. Two photo detectors are placed side by side at so that the light making it through the mask hits one detector after the other to produces the 90o phased pulses.

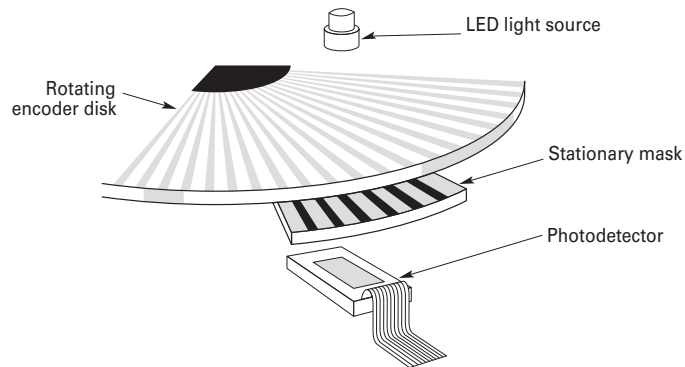

FIGURE 27. Typical quadrature encoder construction

Unlike absolute encoders, incremental encoders have no retention of absolute position upon power loss. When used in positioning applications, the controller must move the motor until a limit switch is reached. This position is then used as the zero reference for all subsequent moves.

Recommended Encoder Types

The module may be used with most incremental encoder module as long as they include the following features:

- Two quadrature outputs (Ch A, Ch B), single ended or differential signals
- 3.0V minimum swing between 0 Level and 1 Level on quadrature output
- 5VDC operation. 50mA or less current consumption per encoder

More sophisticated incremental encoders with index, and other features may be used, however these additional capabilities will be ignored.

The choice of encoder resolution is very wide and is constrained by the module's maximum pulse count at the high end and measurement resolution for speed at the low end.

Specifically, the controller's encoder interface can process 1 million counts per second (30 000 counts per second max on SDCxxxx). As discussed above, a count is generated for each transition on the Channel A and Channel B. Therefore the module will work with encoders outputting up to 62,500 pulses per second.

Commercial encoders are rated by their numbers of "Pulses per Revolution" (also sometimes referred as "Number of Lines" or "Cycles per Revolution"). Carefully read the manufacturer's datasheet to understand whether this number represents the number of pulses that are output by each channel during the course of a 360o revolution rather than the total number of transitions on both channels during a 360o revolution. The second number is 4 times larger than the first one.

The formula below gives the pulse frequency at a given RPM and encoder resolution in Pulses per Revolution.

$$\text{Pulse Frequency in counts per second} = \text{RPM} / 60 * \text{PPR} * 4$$

Example: a motor spinning at 10,000 RPM max, with an encoder with 200 Pulses per Revolution would generate:

$10,000 / 60 * 200 * 4 = 133.3 \text{ kHz}$ which is well within the 1MHz maximum supported by the encoder input.

An encoder with a 200 Pulses per Revolutions is a good choice for most applications.

A higher resolution will cause the counter to count faster than necessary and possibly reach the controller's maximum frequency limit.

An encoder with a much lower resolution will cause speed to be measured with less precision.

Connecting the Encoder

Encoders connect directly to pins present on the controller's connector. The connector provides 5V power to the encoders and has inputs for the two quadrature signals from each encoder. The figure below shows the connection to the encoder.

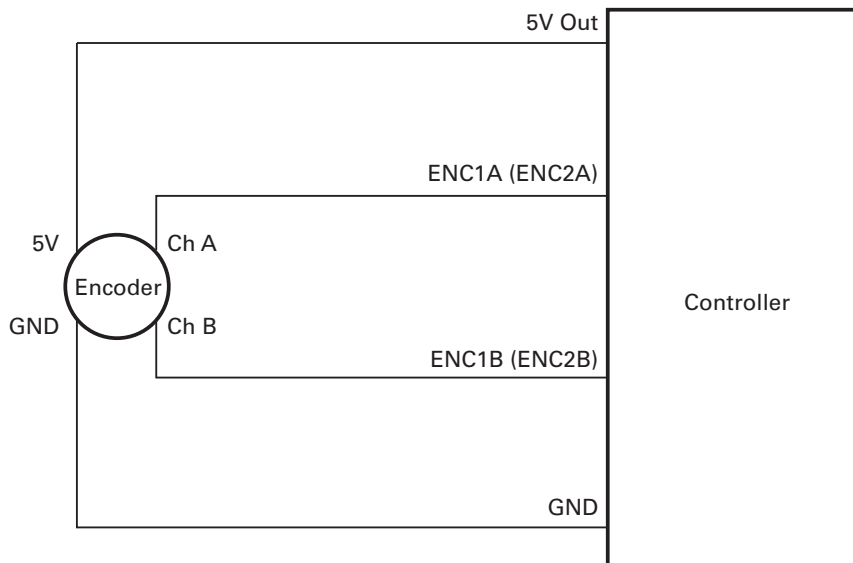

FIGURE 28. Controller connection to typical Encoder

Cable Length and Noise Considerations

Cable should not exceed one 3' (one meter) to avoid electrical noise to be captured by the wiring. A ferrite core filter must be inserted near the controller for length beyond 2' (60 cm). For longer cable length use an oscilloscope to verify signal integrity on each of the pulse channels and on the power supply.

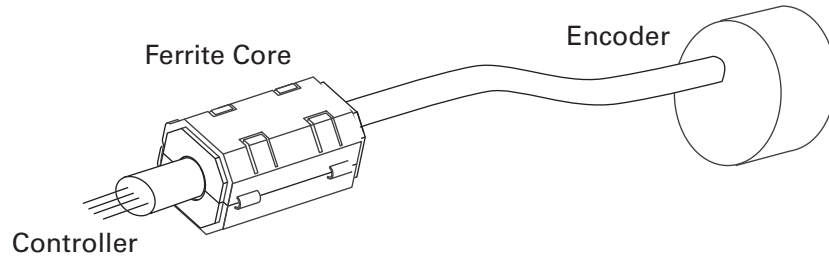

FIGURE 29. Use ferrite core on cable length beyond 2' or 60cm

Important Warning

Excessive cable length will cause electrical noise to be captured by the controller and cause erratic functioning that may lead to failure. In such situation, stop operation immediately.

Motor - Encoder Polarity Matching

When using encoders for closed loop speed or position control, it is imperative that when the motor is turning in the forward direction, the counter increments its value and a positive speed value is measured. The counter value can be viewed using the PC utility.

If the Encoder counts backwards when the motor moves forward, correct this by either:

1- Swapping Channel A and Channel B on the encoder connector. This will cause the encoder module to reverse the count direction, or

2- Swapping the leads on the motor. This will cause the motor to rotate in the opposite direction.

SECTION 4

Command Modes

This section discusses the controller's normal operation in all its supported operating modes.

Input Command Modes and Priorities

The controller will accept commands from one of the following sources

- Serial data (RS232, USB, MicroBasic script)
- Pulse (R/C radio, PWM, Frequency)
- Analog signal (0 to 5V)
- Spektrum Radio (on selected models)
- CAN Interface

One, many or all command modes can be enabled at the same time. When multiple modes are enabled, the controller will select which mode to use based on a user selectable priority scheme.

Setting the priorities is done using the PC configuration utility. See "Commands Parameters" on page 233.

This scheme uses a priority table containing three parameters and let you select which mode must be used in each priority order. During operation, the controller reads the first priority parameter and switches to that command mode. If that command mode is found to be active, that command is then used. If no valid command is detected, the controller switches to the mode defined in the next priority parameter. If no valid command is recognized in that mode, the controller then repeats the operation with the third priority parameter. If no valid command is recognized in that last mode, the controller applies a default command value that can be set by the user (typically 0).

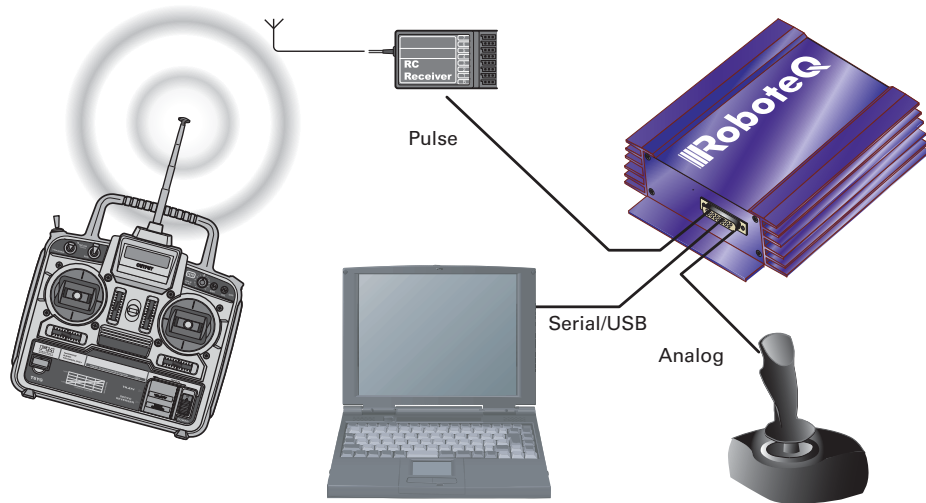

FIGURE 30. Controller’s possible command modes

In the Serial mode, the mode is considered as active if commands (starting with “!”) arrive within the watchdog timeout period via the RS232 or USB ports. The mode will be considered inactive, and the next lower priority level will be selected as soon as the watchdog timer expires. Note that disabling the watchdog will cause the serial mode to be always active after the first command is received, and the controller will never switch to a lower priority mode.

In the pulse mode, the mode is considered active if a valid pulse train is found and remains present.

In analog mode, the mode is considered active at all time, unless the Center at Start safety is enabled. In this case, the Analog mode will activate only after the joystick has been centered. The Keep within Min/Max safety mode will also cause the analog mode to become inactive, and thus enable the next lower priority mode, if the input is outside of a safe range.

The example in Figure 30 shows the controller connected to a microcomputer, a RC radio, and an analog joystick. If the priority registers are set as in the configuration below:

- 1- Serial
- 2- Pulse
- 3- Analog

then the active command at any given time is given in the table below.

TABLE 4. Priority resolution example

Microcomputer Sending commands	Valid Pulses Received	Analog joystick within safe Min/Max	Command mode selected
Yes	Don't care	Don't care	Serial
No	Yes	Don't care	RC mode
No	No	Yes	Analog mode
No	No	No	User selectable default value

Note that it is possible to set a priority level to “None”. For example, the priority table

- 1 - Serial
- 2 - RC Pulse
- 3 - None

will only arbitrate and use Serial or RC Pulse commands.

USB vs Serial Communication Arbitration

On controllers equipped with a USB port, commands may arrive through the RS232 or the USB port at the same time. They are executed as they arrive in a first come first served manner. Commands that are arriving via USB are replied on USB. Commands arriving via the UART are replied on the UART. Redirection symbol for redirecting outputs to the other port exists (e.g. a command can be made to respond on USB even though it arrived on RS232).

CAN Commands Arbitration

On controllers fitted with a CAN interface, commands received via CAN are processed as they arrive regardless if any other mode is active at the same time. Care must be taken to avoid conflicting commands from different sources. Queries of operating parameters will not interfere with queries from serial or USB.

Commands issued from MicroBasic scripts

When sending a Motor or Digital Output command from a MicroBasic script, it will be interpreted by the controller the same way as a serial command (RS232 or USB). If a serial command is received from the serial/USB port at the same time a command is sent from the script, both will be accepted and this can cause conflicts if they are both relating to the same channel. Care must be taken to keep to avoid, for example, cases where the script commands one motor to go to a set level while a serial command is received to set the motor to a different level.

Important Warning

When running a script that sends motor command, make sure you click “Mute” in the PC utility. Otherwise, the PC will be sending motor commands continuously and these will interfere with the script commands.

Script commands are also subject to the serial Watchdog timer and share the same priority level as Serial commands. Use the “Command Priorities” on page 114 to set the priority of commands issued from the script vs commands received from the Pulse Inputs or Analog Inputs.

Operating the Controller in RC mode

The controller can be directly connected to an R/C receiver. In this mode, the speed or position information is contained in pulses whose width varies proportionally with the joysticks’ positions. The controller mode is compatible with all popular brands of RC transmitters.

The RC mode provides the simplest method for remotely controlling a robotic vehicle: little else is required other than connecting the controller to the RC receiver and powering it On.

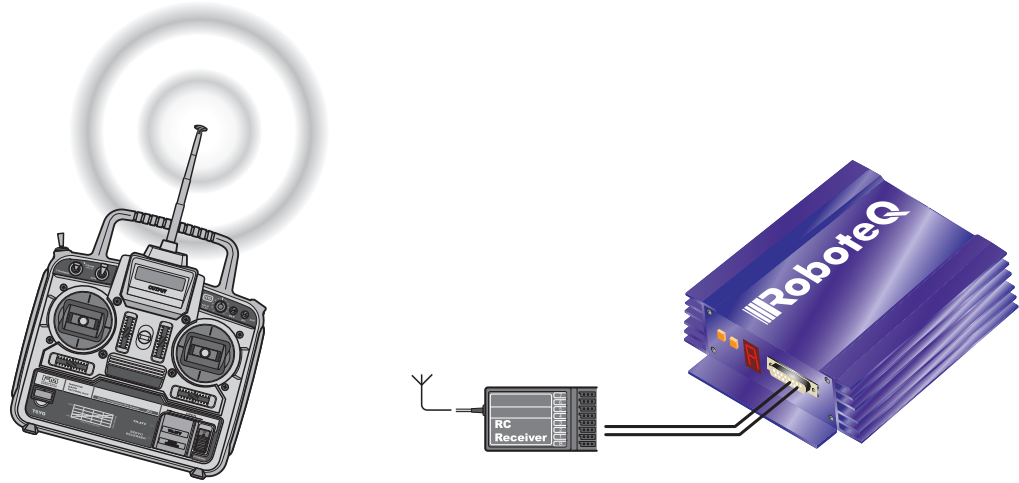

FIGURE 31. R/C radio control mode

The speed or position information is communicated to the controller by the width of a pulse from the RC receiver: a pulse width of 1.0 millisecond indicates the minimum joystick position and 2.0 milliseconds indicates the maximum joystick position. When the joystick is in the center position, the pulse should be 1.5ms.

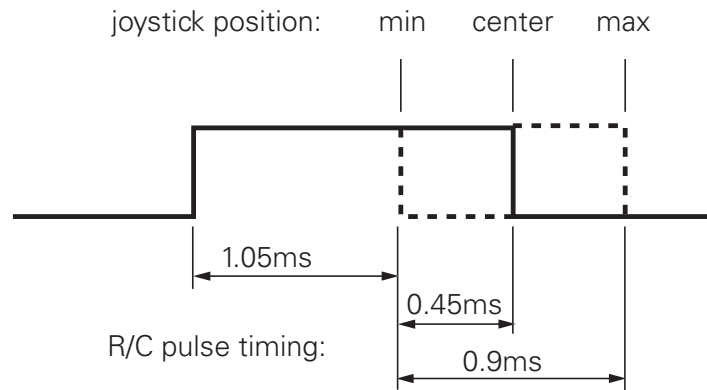

FIGURE 32. Joystick position vs. pulse duration default values

The controller has a very accurate pulse capture input and is capable of detecting changes in joystick position (and therefore pulse width) as small as 0.1%. This resolution is superior to the one usually found in most low cost RC transmitters. The controller will therefore be able to take advantage of the better precision and better control available from a higher quality RC radio, although it will work fine with lesser expensive radios as well.

Input RC Channel Selection

The controller features 5 or 6 inputs, depending on the model type, that can be used for pulse capture. Using different configuration parameters, any RC input can be used as command for any motor channels. The controller's factory default defines two channels for RC

capture. Which channel and which pin on the input connector depends on the controller model and can be found in the controller's datasheet.

Changing the input assignment is done using the PC Configuration utility. See "Pulse Inputs Configurations and Uses" on page 68.

Input RC Channel Configuration

Internally, the measured pulse width is compared to the reference minimum, center and maximum pulse width values. From this is generated a command number ranging from -1000 (when the joystick is in the min. position), to 0 (when the joystick is in the center position) to +1000 (when the joystick is in the max position). This number is then used to set the motor's desired speed or position that the controller will then attempt to reach.

For best results, reliability and safety, the controller will also perform a series of corrections, adjustments and checks to the R/C commands, as described below.

Automatic Joystick Range Calibration

For best control accuracy, the controller can be calibrated to capture and use your radio's specific timing characteristics and store them into its internal Flash memory. This is done using a simple calibration procedure described on page 66.

Deadband Insertion

The controller allows for a selectable amount of joystick movement to take place around the center position before activating the motors. See the full description of this feature at "Deadband Selection" on page 67

Command Exponentiation

The controller can also be set to translate the joystick motor commands so that the motor respond differently depending on whether the joystick is near the center or near the extremes. Five different exponential or logarithmic translation curves may be applied. Since this feature applies to the R/C, Analog and RS232 modes, it is described in detail in "Exponent Factor Application" on page 68, in the General Operation section of the manual.

Reception Watchdog

Immediately after it is powered on, if in the R/C mode, the controller is ready to receive pulses from the RC radio.

If valid pulses are received on any of the enabled Pulse input channels, the controller will consider the RC Pulse mode as active. If no higher priority command is currently active (See "Input Command Modes and Priorities" on page 55), the captured RC pulses will serve to activate the motors.

If no valid RC pulses reach the controller for more than 500ms, the controller no longer considers it is in the RC mode and a lower priority command type will be accepted if present.

Important Warning

Some receivers include their own supervision of the radio signals and will move their servo outputs to a safe position in case of signal loss. Using these types of receiver, the controller will always be receiving pulses even with the transmitter off.

Using Sensors with PWM Outputs for Commands

The controller's Pulse inputs can be used with various types of angular sensors that use contactless Hall technology and that output a PWM signal. These type of sensors are increasingly used inside joystick and will perform much more reliably, and typically with higher precision than traditional potentiometers.

The pulse shape output from these devices varies widely from one sensor model to another and is typically different than this of RC radios:

- They have a higher repeat rate, up to a couple of kHz.
- The min and max pulse width can reach the full period of the pulse

Care must therefore be exercised when selecting a sensor. The controller will accommodate any pulsing sensor as long as the pulsing frequency does not exceed 250Hz. The sensor should not have pulses that become too narrow - or disappear altogether - at the extremes of their travel. Select sensors with a minimum pulse width of 10us or higher. Alternatively, limit mechanically the travel of the sensor to keep the minimum pulse width within the acceptable range.

A minimum of pulsing must always be present. Without it, the signal will be considered as invalid and lost.

Pulses from PWM sensors can be applied to any Pulse input on the controller's connector. Configure the input capture as Pulse or Duty Cycle.

A Pulse mode capture measures the On time of the pulse, regardless of the pulse period.

A Duty Cycle mode capture measures the On time of the pulse relative to the entire pulse period. This mode is typically more precise as it compensates for the frequency drifts of the PWM oscillator.

PWM signals are then processed exactly the same way as RC pulses. Refer to the RC pulse paragraphs above for reference.

Operating the Controller In Analog Mode

Analog Command is the simplest and most common method when the controller is used in a non-remote, human-operated system, such as Electric Vehicles.

Input Analog Channel Selection

The controller features 4 to 11 inputs, depending on the model type, that can be used for analog capture. Using different configuration parameters, any Analog input can be used as command for any motor channel. The controller's factory default defines two channels as

Analog command inputs. Which channel and which pin on the input connector depends on the controller model and can be found in the controller's datasheet.

Changing the input assignment is done using the PC Configuration utility. See "Analog Inputs Configurations and Use" on page 65.

Input Analog Channel Configuration

An Analog input can be Enabled or Disabled. When enabled, it can be configured to capture absolute voltage or voltage relative to the 5V output that is present on the connector. See "Analog Inputs Configurations and Use" on page 65

Analog Range Calibration

If the joystick movement does not reach full 0V and 5V, and/or if the joystick center point does not exactly output 2.5V, the analog inputs can be calibrated to compensate for this. See "Min, Max and Center adjustment" on page 66 and "Deadband Selection" on page 67.

Using Digital Input for Inverting direction

Any digital input can be configured to change the motor direction when activated. See "Digital Inputs Configurations and Uses" on page 64. Inverting the direction has the same effect as instantly moving the command potentiometer to the same level the opposite direction. The motor will first return to 0 at the configured deceleration rate and go to the inverted speed using the configured acceleration rate.

Safe Start in Analog Mode

By default, the controller is configured so that in Analog command mode, no motor will start until all command joysticks are centered. The center position is the one where the input equals the configured Center voltage plus the deadband.

After that, the controller will respond to changes to the analog input. The safe start check is not performed again until power is turned off.

Protecting against Loss of Command Device

By default, the controller is protected against the accidental loss of connection to the command potentiometer. This is achieved by adding resistors in series with the potentiometer that reduce the range to a bit less than the full 0V to 5V swing. If one or more wires to the potentiometer are cut, the voltage will actually reach 0V and 5V and be considered a fault condition, if that protection is enabled. See "Connecting Potentiometers for Commands with Safety band guards" on page 46.

Safety Switches

Any Digital input can be used to add switch-activated protection features. For example, the motor(s) can be made to activate only if a key switch is turned On, and a passenger is present on the driver's seat. This is done using by configuring the controller's Digital inputs. See "Digital Inputs Configurations and Uses" on page 64.

Monitoring and Telemetry in RC or Analog Modes

The controller can be fully monitored while it is operating in RC or Analog modes. If directly connected to a PC via USB or RS232, the controller will respond to operating queries (Amps, Volts, Temperature, Power Out, ...) without this having any effect on its response to Analog or RC commands. The PC Utility can therefore be used to visualize in real time all operating parameters as the controller runs. See "Run Tab" on page 237.

In case the controller is not connected via a bi-directional link, and can only send information one-way, typically to a remote host, the controller can be configured to output a user-selectable set of operating parameters, at a user selectable repeat rate. See "Query History Commands" on page 188.

Using the Controller with a Spektrum Receiver

Some controller models can be connected directly to a miniature Spektrum receiver. Using only 3 wires this interface will carry the information of up to 6 command joysticks with a resolution and precision that is significantly higher than traditional 1.5ms pulse signals.

The PC utility is used to map any of the 6 channels as a command for each motor. Binding the receiver to the transmitter is done using the %BIND maintenance command. See "Maintenance Commands" on page 190 for details on the binding procedure.

Using the Controller in Serial (USB/RS232) Mode

The serial mode allows full control over the controller's entire functionality. The controller will respond a large set of commands. These are described in detail in "Serial (RS232/USB) Operation" on page 111.

SECTION 5

I/O Configuration and Operation

This section discusses the controller's normal operation in all its supported operating modes.

Basic Operation

The controller's operation can be summarized as follows:

- Receive commands from a radio receiver, joystick or a microcomputer
- Activate the motor according to the received command
- Perform continuous check of fault conditions and adjust actions accordingly
- Report real-time operating data

The diagram below shows a simplified representation of the controller's internal operation. The most noticeable feature is that the controller's serial, digital, analog, pulse and encoder inputs may be used for practically any purpose.

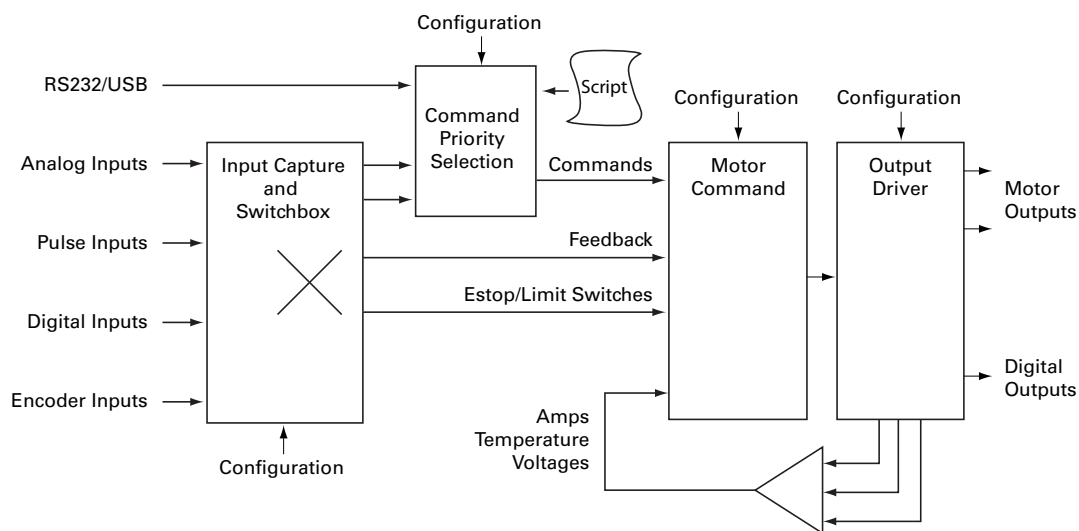

FIGURE 33. Simplified representation of the controller's internal operation

Practically all operating configurations and parameters can be changed by the user to meet any specific requirement. This unique architecture leads to a very high number of possibilities. This section of the manual describes all the possible operating options.

Input Selection

As seen earlier in the controller's simplified internal operating diagram on Figure 33, any input can be used for practically any purpose. All inputs, even when they are sharing the same pins on the connector, are captured and evaluated by the controller. Whether an input is used, and what it is used for, is set individually using the descriptions that follow.

Important Notice

On shared I/O pins, there is nothing stopping one input to be used as analog or pulse at the same time or for two separate inputs to act identically or in conflict with one another. While such an occurrence is normally harmless, it may cause the controller to behave in unexpected manner and/or cause the motors not to run. Care must be exercised in the configuration process to avoid possible redundant or conflictual use.

Digital Inputs Configurations and Uses

Each of the controller's digital Inputs can be configured so that they are active high or active low. Each output can also be configured to activate one of the actions from the list in the table below. In multi-channel controller models, the action can be set to apply to any or all motor channels.

TABLE 5. Digital Input Action List

Action	Applicable Channel	Description
No Action	-	Input causes no action
Safety Stop	Selectable	Stops the selected motor(s) channel until command is moved back to 0 or command direction is reversed
Emergency stop	All	Stops the controller entirely until controller is powered down, or a special command is received via the serial port
Motor Stop (deadman switch)	Selectable	Stops the selected motor(s) while the input is active. Motor resumes when input becomes inactive
Invert motor direction	Selectable	Inverts the motor direction, regardless of the command mode in used
Forward limit switch	Selectable	Stops the motor until command is changed to reversed
Reverse limit switch	Selectable	Stops the motor until the command is changed forward
Run script	NA	Start execution of MicroBasic script
Load Home counter	Selectable	Load counter with Home value

Configuring the Digital Inputs and the Action to use can be done very simply using the PC Utility. See “Digital Input and Output Parameters” on page 235.

Wiring instructions for the Digital Inputs can be found in “Connecting Switches or Devices to Inputs shared with Outputs” on page 44

Analog Inputs Configurations and Use

The controller can do extensive conditioning on the analog inputs and assign them to different use.

Each input can be disabled or enabled. When enabled, it is possible to select the whether capture must be as absolute voltage or relative to the controller’s 5V Output. Details on how to wire analog inputs and the differences between the Absolute and Relative captures can be found in “Using the Analog Inputs to Monitor External Voltages” on page 50.

TABLE 6. Analog Capture Modes

Analog Capture Mode	Description
Disabled	Analog capture is ignored (forced to 0)
Absolute	Analog capture measures real volts at the input
Relative	Analog captured is measured relative to the 5V Output which is typically around 4.8V. Correction is applied so that an input voltage measured to be the same as the 5V Output voltage is reported at 5.0V

The raw Analog capture then goes through a series of processing shown in the diagram below.

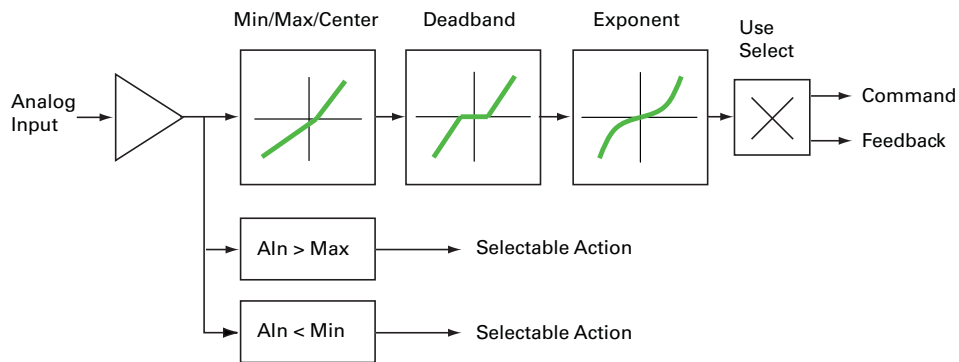

FIGURE 34. Analog Input processing chain

Analog Min/Max Detection

An analog input can be configured so that an action is triggered if the captured value is above a user-defined Maximum value and/or under a user-defined Minimum value. The actions that can be selected are the same as these that can be triggered by the Digital Input. See the list and description in Table 5, "Digital Input Action List," on page 64

Min, Max and Center adjustment

The raw analog capture is then scaled into a number ranging from -1000 to +1000 based on user-defined Minimum, Maximum and Center values for the input. For example, setting the minimum to 500mV, the center to 2000mV, and the maximum to 4500mV, will produce the output to change in relation to the input as shown in the graph below

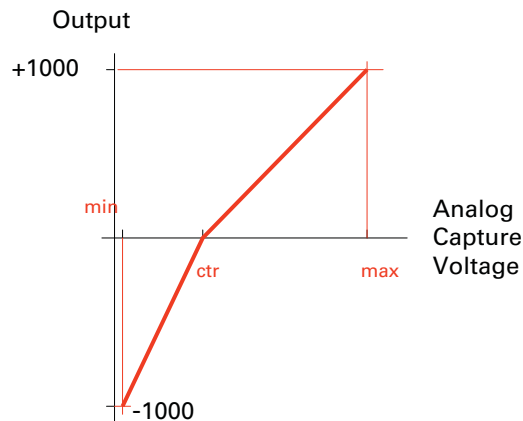

FIGURE 35. Analog Input processing chain

This feature allows to capture command or feedback values that match the available range of the input sensor (typically a potentiometer).

For example, this capability is useful for modifying the active joystick travel area. The figure below shows a transmitter whose joystick's center position has been moved back so that the operator has a finer control of the speed in the forward direction than in the reverse position.

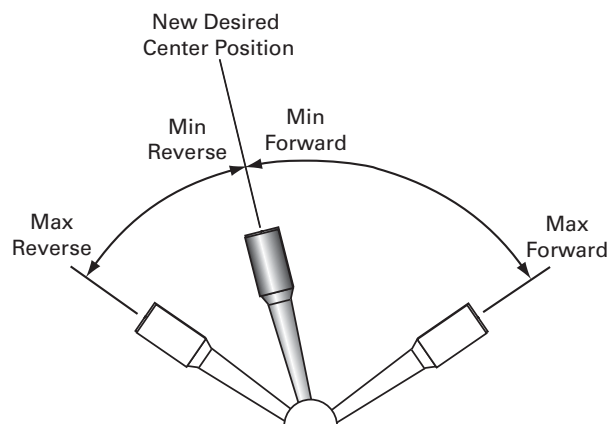

FIGURE 36. Calibration example where more travel is dedicated to forward motion

The Min, Max and Center values are defined individually for each input. They can be easily entered manually using the Roborun PC Utility. The Utility also features an Auto-calibration function for automatically capturing these values. See "Automatic Analog and Pulse input Calibration" on page 230

Deadband Selection

The adjusted analog value is then adjusted with the addition of a deadband. This parameter selects the range of movement change near the center that should be considered as a 0 command. This value is a percentage from 0 to 50% and is useful, for example, to allow some movement of a joystick around its center position before any power is applied to a motor. The graph below shows output vs input changes with a deadband of approximately 40%.

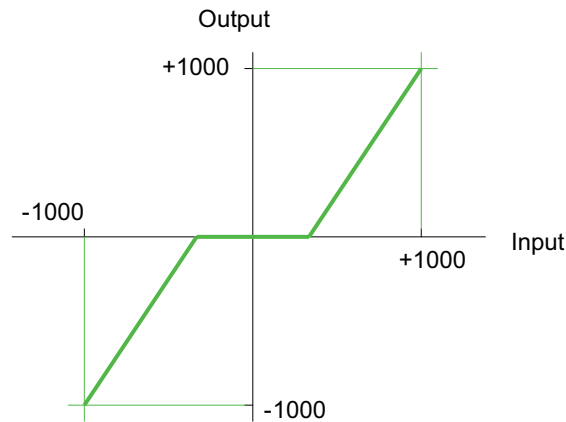

FIGURE 37. Effect of deadband on the output

Note that the deadband only affects the start position at which the joystick begins to take effect. The motor will still reach 100% when the joystick is at its full position. An illustration of the effect of the deadband on the joystick action is shown in the Figure 38 below.

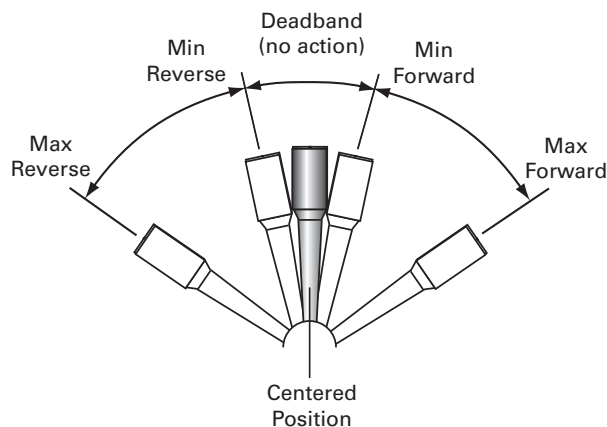

FIGURE 38. Effect of deadband on joystick position vs. motor command

The deadband value is set independently for each input using the PC configuration utility.

Exponent Factor Application

An optional exponential or a logarithmic transformation can then be applied to the signal. Exponential correction will make the commands change less at the beginning and become stronger at the end of the joystick movement. The logarithmic correction will have a stronger effect near the start and lesser effect near the end. The linear selection causes no change to the input. There are 3 exponential and 3 logarithmic choices: weak, medium and strong. The graph below shows the output vs input change with exponential, logarithmic and linear corrections.

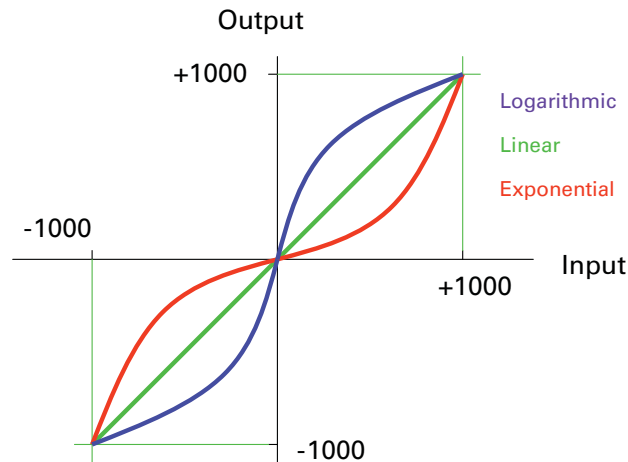

FIGURE 39. Effect of exponential / logarithmic correction on the output

The exponential or log correction is selected separately for each input using the PC Configuration Utility.

Use of Analog Input

After the analog input has been fully processed, it can be used as a motor command or, if the controller is configured to operate in closed loop, as a feedback value (typically speed or position).

Each input can therefore be configured to be used as command or feedback for any motor channel(s). The mode and channel(s) to which the analog input applies are selected using the PC Configuration Utility.

Pulse Inputs Configurations and Uses

The controller's Pulse Inputs can be used to capture pulsing signals of different types.

TABLE 7. Analog Capture Modes

Capture Mode	Description	Typical use
Disabled	Pulse capture is ignored (forced to 0)	
Pulse	Measures the On time of the pulse	RC Radio

TABLE 7. Analog Capture Modes

Capture Mode	Description	Typical use
Duty Cycle	Measures the On time relative to the full On/Off period	Hall position sensors and joysticks with pulse output
Frequency	Measures the repeating frequency of pulse	Encoder wheel

The capture mode can be selected using the PC Configuration Utility.

The captured signals are then adjusted and can be used as command or feedback according to the processing chain described in the diagram below.

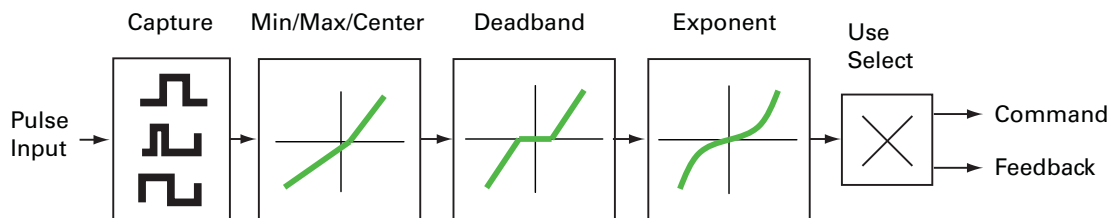

FIGURE 40. Pulse Input processing chain

Except for the capture, all other steps are identical to these described for the Analog capture mode. See:

“Min, Max and Center adjustment” on page 66

“Deadband Selection” on page 67

“Exponent Factor Application” on page 68

Use of Pulse Input

After the pulse input has been fully processed, it can be used as a motor command or, if the controller is configured to operate in closed loop, as a feedback value (typically speed or position).

Each input can therefore be configured to be used as command or feedback for any motor channel(s). The mode and channel(s) to which the analog input applies are selected using the PC Configuration Utility.

Digital Outputs Configurations and Triggers

The controller's digital outputs can individually be mapped to turn On or Off based on the status of user-selectable internal status or events. The table below lists the possible assignment for each available Digital Output.

Action	Output activation	Typical Use
No action	Not changed by any internal controller events.	Output may be activated using Serial commands or user scripts
Motor(s) is on	When selected motor channel(s) has power applied to it.	Brake release
Motor(s) is reversed	When selected motor channel(s) has power applied to it in reverse direction.	Back-up warning indicator
Overvoltage	When battery voltage above over-limit	Shunt load activation
Overtemperature	When over-temperature limit exceeded	Fan activation. Warning buzzer
Status LED	When status LED is ON	Place Status indicator in visible location.

Encoder Configurations and Use

On controller models equipped with encoder inputs, external encoders enable a range of precision motion control features. See "Connecting Optical Encoders" on page 51 for a detailed discussion on how optical encoders work and how to physically connect them to the controller. The diagram below shows the processing chain for each encoder input

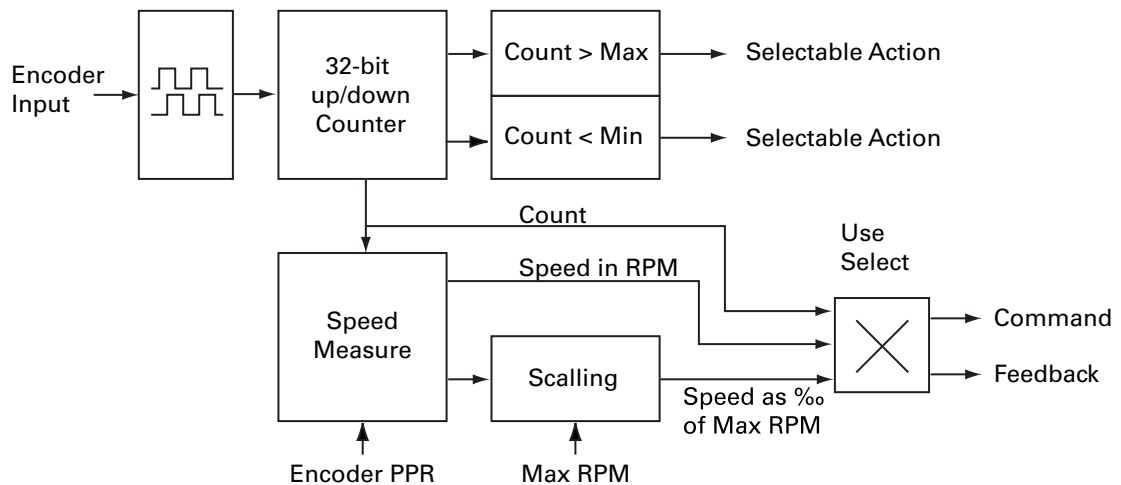

FIGURE 41. Encoder input processing

The encoder's two quadrature signals are processed to generate up and down counts depending on the rotation direction. The counts are then summed inside a 32-bit counter. The counter can be read directly using serial commands and/or can be used as a position feedback source for the closed loop position mode.

The counter can be compared to user-defined Min and/or Max values and trigger action if these limits are reached. The type actions are the same as these selectable for Digital Inputs and described in “Digital Inputs Configurations and Uses” on page 64.

The count information is also used to measure rotation speed. Using the Encoder Pulse Per Rotation (PPR) configuration parameter, the output is a speed measurement in actual RPM that is useful in closed loop speed modes where the desired speed is set as a numerical value, in RPM, using a serial command.

The speed information is also scaled to produce a relative number ranging from -1000 to +1000 relative to a user-configured arbitrary Max RPM value. For example, with the Max RPM configured as 3000, a motor rotating at 1500 RPM will output a relative speed of 500. Relative speed is useful for closed loop speed mode that use Analog or Pulse inputs as speed commands.

Configuring the encoder parameters is done easily using the PC Configuration Utility. See “Encoder Parameters” on page 234 for details.

Hall Sensor Inputs

On brushless motor controllers, the Hall Sensors that are used to switch power around the motor windings, are also used to measure speed and distance travelled.

Speed is evaluated by measuring the time between transition of the Hall Sensors. A 32 bit up/down counter is also updated at each Hall Sensor transition.

Speed information picked up from the Hall Sensors can be used for closed loop speed operation without any additional hardware.

SECTION 6

Motor Operating Features and Options

This section discusses the controller's operating features and options relating to its motor outputs.

Power Output Circuit Operation

The controller's power stage is composed of high-current MOSFET transistors that are rapidly pulsed on and off using Pulse Width Modulation (PWM) technique in order to deliver more or less power to the motors. The PWM ratio that is applied is the result of computation that combines the user command and safety related corrections. In closed-loop operation, the command and feedback are processed together to produce the adjusted motor command. The diagram below gives a simplified representation of the controller's operation.

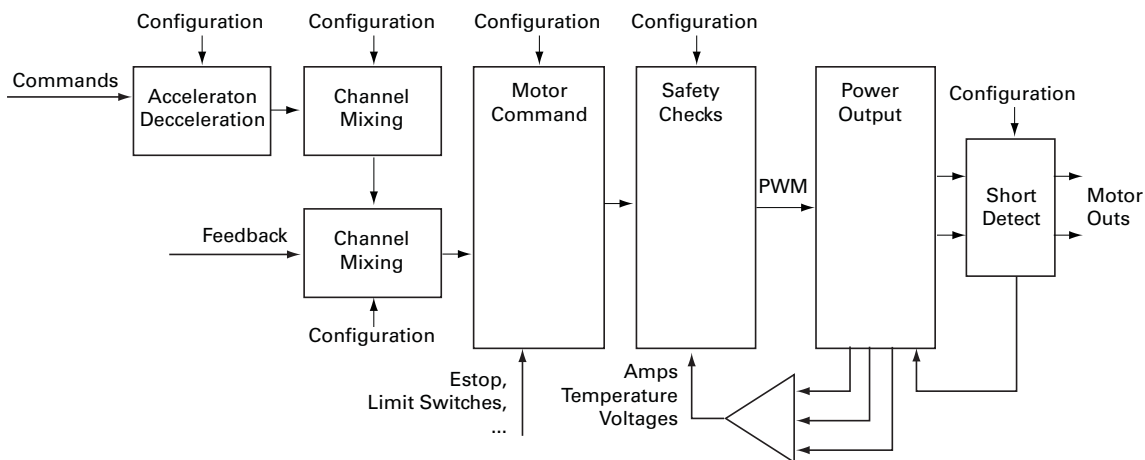

FIGURE 42. Simplified diagram of Power Stage operation

Global Power Configuration Parameters

PWM Frequency

The power MOSFETs are switched at 18kHz by default. This frequency can be set to another value ranging from 10 kHz to 32 kHz. Increasing the frequency reduces the efficiency due to switching losses. Lowering the frequency eventually creates audible noise and can be inefficient on low inductance motors.

Changing the PWM frequency results in no visible change in the motor operation and should be left untouched.

Overvoltage Protection

The controller includes a battery voltage monitoring circuit that will cause the output transistors to be turned Off if the main battery voltage rises above a preset Over Voltage threshold. The value of that threshold is set by default and may be adjusted by the user. The default value and settable range is given in the controller model datasheet.

This protection is designed to prevent the voltage created by the motors during regeneration to be “amplified” to unsafe levels by the switching circuit.

The controller will resume normal operation when the measured voltage drops below the Over Voltage threshold.

The controller can also be configured to trigger one of its Digital Outputs when an Over Voltage condition is detected. This Output can then be used to activate a Shunt load across the VMot and Ground wires to absorb the excess energy if it is caused by regeneration. This protection is particularly recommended for situations where the controller is powered from a power supply instead of batteries.

Undervoltage Protection

In order to ensure that the power MOSFET transistors are switched properly, the controller monitors the internal preset power supply that is used by the MOSFET drivers. If the internal voltage drops below a safety level, the controller’s output stage is turned Off. The rest of the controller’s electronics, including the microcomputer, will remain operational as long as the power supply on VMot or Power Control is above 7V.

Additionally, the output stage will be turned off when the main battery voltage on VMot drops below a user configurable level that is factory preset at 5V.

Temperature-Based Protection

The controller features active protection which automatically reduces power based on measured operating temperature. This capability ensures that the controller will be able to work safely with practically all motor types and will adjust itself automatically for the various load conditions.

When the measured temperature reaches 70°C, the controller’s maximum power output begins to drop until the temperature reaches 80°C. Above 80°C, the controller’s power stage turns itself off completely.

Note that the measured temperature is measured on the heat sink near the Power Transistors and will rise and fall faster than the outside surface.

The time it takes for the heat sink's temperature to rise depends on the current output, ambient temperature, and available air flow (natural or forced).

Short Circuit Protection

The controller includes a circuit that will detect very high current surges that are consistent with short circuits conditions. When such a condition occurs, the power transistor for the related motor channel are cut off within a few microseconds. Conduction is restored at 1ms intervals. If the short circuit is detected again for up to a quarter of a second, it is considered as a permanent condition and the controller enters a Safety Stop condition, meaning that it will remain off until the command is brought back to 0.

The short circuit detection can be configured with the PC utility to have one of three sensitivity levels: quick, medium, and slow.

The protection is very effective but has a few restrictions:

Only shorts between two motor outputs of the same channel are detected. Shorts between a motor wire and VMot are also detected. **Shorts between a motor output and Ground are not detected.**

Wire inductance causes current to rise slowly relative to the PWM On/Off times. Short circuit will typically not be detected at low PWM ratios, which can cause significant heat to eventually accumulate in the wires, load and the controller, even though the controller will typically not suffer direct damage. Increasing the short circuit sensitivity will lower the PWM ratio at which a short circuit is detected.

Since the controller can handle very large current during its normal operation, Only direct short circuits between wires will cause sufficiently high current for the detection to work. Short circuits inside motors or over long motor wires may go undetected.

A simplified short circuit protection logic is implemented on some controller models. Check with controller datasheet for details.

Mixing Mode Select

Mixed mode is available as a configuration option in dual channel controllers to create tank-like steering when one motor is used on each side of the robot: Channel 1 is used for moving the robot in the forward or reverse direction. Channel 2 is used for steering and will change the balance of power on each side to cause the robot to turn. Figure 43 below illustrates how the mixed mode motor arrangement.

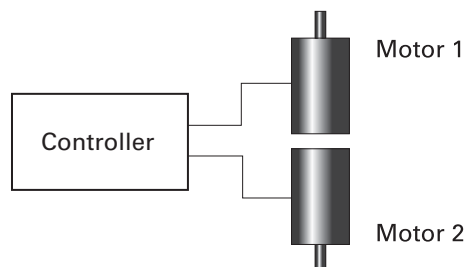

FIGURE 43. Effect of commands to motor examples in mixed mode

The controller supports 3 mixing algorithms with different driving characteristics. The table below shows how each motor output responds to the two commands in each of these modes.

TABLE 8. Mixing Mode characteristics

Input		Mode 1		Mode 2		Mode 3	
Throttle	Steering	M1	M2	M1	M2	M1	M2
0	0	0	0	0	0	0	0
0	300	300	-300	300	-300	300	-300
0	600	600	-600	600	-600	600	-600
0	1000	1000	-1000	1000	-1000	1000	-1000
0	-300	-300	300	-300	300	-300	300
0	-600	-600	600	-300	300	-600	600
0	-1000	-1000	1000	-1000	1000	-1000	1000
300	300	600	0	600	0	522	90
300	600	900	-300	900	-300	762	-120
300	1000	1000	-700	1000	-1000	1000	-400
300	-300	0	600	0	600	90	522
300	-600	-300	900	-300	900	-120	762
300	-1000	-700	1000	-1000	1000	-400	1000
600	300	900	300	900	300	708	480
600	600	1000	0	1000	-200	888	360
600	1000	1000	-400	1000	-1000	1000	200
600	-300	300	900	300	900	480	708
600	-600	0	1000	-200	1000	360	888
600	-1000	-400	1000	-1000	1000	200	1000
1000	300	1000	700	1000	400	900	1000
1000	600	1000	400	1000	-200	1000	1000
1000	1000	1000	0	1000	-1000	1000	1000
1000	-300	700	1000	400	1000	1000	900
1000	-600	400	1000	-200	1000	1000	1000
1000	-1000	0	1000	-1000	1000	1000	1000

Motor Channel Parameters

User Selected Current Limit Settings

The controller has current sensors at each of its output stages. Every 1 ms, this current is measured and a correction to the output power level is applied if higher than the user pre-set value.

The current limit may be set using the supplied PC utility. The maximum limit is dependent on the controller model and can be found on the product datasheet.

The limitation is performed on the Motor current and not on the Battery current. See “Battery Current vs. Motor Current” on page 28 for a discussion of the differences.

Selectable Amps Threshold Triggering

The controller can be configured to detect when the Amp on a motor channel exceed a user-defined threshold value and trigger an action if this condition persists for more than a preset amount of time.

The list of actions that may be triggered is shown in the table below.

TABLE 9. Possible Action List when Amps threshold is exceeded

Action	Applicable Channel	Description
No Action	-	Input causes no action
Safety Stop	Selectable	Stops the selected motor(s) channel until command is moved back to 0 or command direction is reversed
Emergency stop	All	Stops the controller entirely until controller is powered down, or a special command is received via the serial port

This feature is very different than amps limiting. Typical uses for it are for stall detection or “soft limit switches”. When, for example, a motor reaches an end and enters stall condition, the current will rise, and that current increase can be detected and the motor be made to stop until the direction is reversed.

Programmable Acceleration & Deceleration

When changing speed command, the controller will go from the present speed to the desired one at a user selectable acceleration. This feature is necessary in order to minimize the surge current and mechanical stress during abrupt speed changes.

This parameter can be changed by using the PC utility. Acceleration can be different for each motor. A different value can also be set for the acceleration and for the deceleration. The acceleration value is entered in RPMs per second. In open loop installation, where speed is not actually measured, the acceleration value is relative to the Max RPM parameter. For example, if the Max RPM is set to 1000 (default value) and acceleration to 2000, this means that the controller will go from 0 to 100% power in 0.5 seconds.

Important Warning

Depending on the load’s weight and inertia, a quick acceleration can cause considerable current surges from the batteries into the motor. A quick deceleration will cause an equally large, or possibly larger, regeneration current surge. Always experiment with the lowest acceleration value first and settle for the slowest acceptable value.

Forward and Reverse Output Gain

This parameter lets you select the scaling factor for the power output as a percentage value. This feature is used to connect motors with voltage rating that is less than the battery voltage. For example, using a factor of 50% it is possible to connect a 12V motor onto a 24V system, in which case the motor will never see more than 12V at its input even when the maximum power is applied.

Selecting the Motor Control Modes

For each motor, the controller supports multiple motion control modes. The controller's factory default mode is Open Loop Speed control for each motor. The mode can be changed using the Roborun PC utility.

Open Loop Speed Control

In this mode, the controller delivers an amount of power proportional to the command information. The actual motor speed is not measured. Therefore the motor will slow down if there is a change in load as when encountering an obstacle and change in slope. This mode is adequate for most applications where the operator maintains a visual contact with the robot.

Closed Loop Speed Control

In this mode, illustrated in Figure 44, optical encoder (typical) or an analog tachometer is used to measure the actual motor speed. If the speed changes because of changes in load, the controller automatically compensates the power output. This mode is preferred in precision motor control and autonomous robotic applications. Details on how to wire the tachometer can be found in "Connecting Tachometer to Analog Inputs" on page 47. Closed Loop Speed control operation is described in "Closed Loop Speed Mode" on page 87. On brushless motors, speed may be sensed directly from the motor's Hall Sensors and closed loop operation is possible without additional hardware.

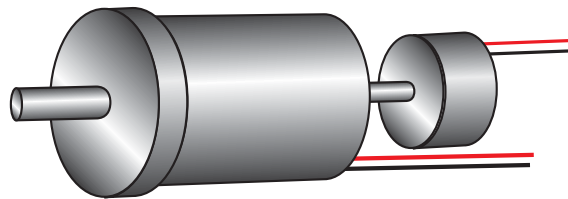

FIGURE 44. Motor with tachometer or Encoder for Closed Loop Speed operation

Closed Loop Position Relative Control

In this mode, illustrated in Figure 45, the axle of a geared down motor is typically coupled to a position sensor that is used to compare the angular position of the axle versus a desired position. The motor will move following a controlled acceleration up to a user defined velocity, and decelerate to smoothly reach the desired destination. This feature of the controller makes it possible to build ultra-high torque "jumbo servos" that can be used to drive steering columns, robotic arms, life-size models and other heavy loads. Details on how to wire the position sensing potentiometers and operating in this mode can be found in "Closed Loop Relative and Tracking Position Modes" on page 93.

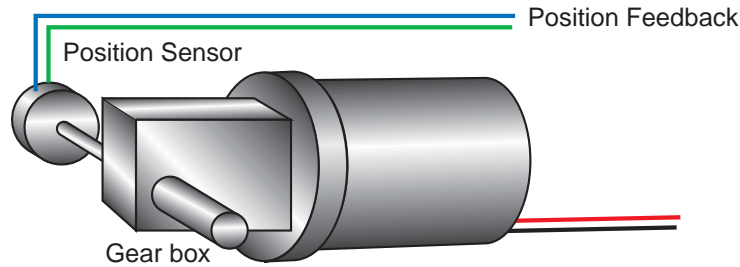

FIGURE 45. Motor with potentiometer assembly for Position operation

Closed Loop Count Position

In this mode, an encoder is attached to the motor as for the Speed Mode of Figure 44. Then, the controller can be instructed to move the motor to a specific number of counts, using a user-defined acceleration, velocity, and deceleration profile. Details on how to configure and use this mode can be found in "Closed Loop Count Position Mode" on page 103.

Closed Loop Tracking

This mode uses the same feedback sensor mount as this of Figure 45. In this mode the motor will be moved until the final position measured by the feedback sensor matches the command. The motor will move as fast as it possibly can, using maximum physical acceleration. This mode is best for systems where the motor can be expected to move as fast as the command changes. Details on this operating mode can be found in "Closed Loop Relative and Tracking Position Modes" on page 93.

Torque Mode

In this closed loop mode, the motor is driven in a manner that it produces a desired amount of torque regardless of speed. This is achieved by using the motor current as the feedback. Torque mode does not require any specific wiring. Detail on this operating mode can be found in "Closed Loop Torque Mode" on page 107.

SECTION 7

Brushless Motor Connections and Operation

This section addresses installation and operating issues specific to brushless motors. It is applicable only to brushless motor controller models.

Brushless Motor Introduction

Brushless motors, or more accurately Brushless DC Permanent Magnet motors (since there are other types of motors without brushes) contain permanent magnets and electromagnets. The electromagnets are arranged in groups of three and are powered in sequence in order to create a rotating field that drives the permanent magnets. The electromagnets are located on the non-rotating part of the motor, which is normally in the motor casing for traditional motors, in which case the permanent magnets are on the rotor that is around the motor shaft. On hub motors, such as those found on electric bikes, scooters and some other electric vehicles, the electromagnets are on the center part of the motor and the permanent magnets on outer part.

As the name implies, Brushless motors differ from traditional DC motors in that they do not use brushes for commutating the electromagnets. Instead, it is up to the motor controller to apply, in sequence, current to each of the 3 motor windings in order to cause the rotor to spin. To do this, the controller must know where the rotor is in relation to the electromagnets so that current can be applied to the correct winding at any given point in time. The simplest and most reliable method is to use three Hall sensors inside the motor. The diagram below shows the direction of the current in each of the motor's windings depending on the state of the 3 hall sensors.

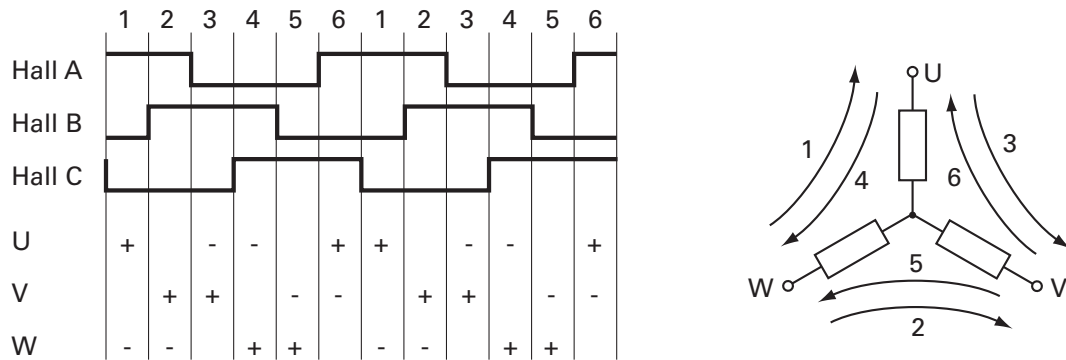

FIGURE 46. Hall sensors sequence

Roboteq's brushless DC motor controllers only work with motors equipped with Hall sensors. While sensorless techniques exist, these can only accurately detect the rotor position once the motor is spinning, and therefore are not usable in any system requiring precise control at slow speed.

Number of Poles

One of the key characteristics of a brushless motor is the number of poles of permanent magnets it contains. A full 3-phase cycling of motor's electromagnets will cause the rotor to move to the next permanent magnet pole. Thus, increasing the number of poles will cause the motor to rotate more slowly for a given rate of change on the winding's phases.

A higher or lower number of poles makes no difference to the controller since its function is always to create a rotating field based on the Hall sensor position. However, the number of poles information can be used to determine the number of turns a motor has done. It can also be used to measure the motor speed. The Roboteq controllers can measure both.

The number of poles on a particular motor is usually found in the motor's specification sheet. The number of poles can also be measured by applying a low DC current (around 1A) between any two wires of the 3 that go to the motor and then counting the number of cogs you feel when rotating the motor by hand for a full turn. It can also be determined by rotating the motor shaft by hand a full turn. Then take the number of counts reported by the hall counter, and divide it by 6.

The number of poles is a configuration parameter that can be entered in the controller configuration (see "BPOL" on page 213). This parameter is not needed for basic motor operation and can be left at its default value. It is needed if accurate speed reporting is required or to operate in Closed Loop Speed mode.

Entering a negative number of poles will reverse the measured speed and the count direction. It is useful when operating the motor in closed loop speed mode and if otherwise a negative speed is measured when the motor is moved in the positive direction.

Hall Sensor Wiring

Hall sensors connection requires 5 wires on the motor:

- Ground
- Sensor1 Output
- Sensor2 Output

- Sensor3 Output
- + power supply

Sensor outputs are generally Open Collector, meaning that they require a pull up resistor in order to create the logic level 1. Pull up resistor of 4.7K ohm to +5V are incorporated inside all controllers. Additionally, 1nF capacitors to ground are present at the controller's input in order to remove high frequency spikes which may be induced by the switching at the motor wires. The controller's input buffers are Schmitt triggers to ensure a clean transition between high and low.

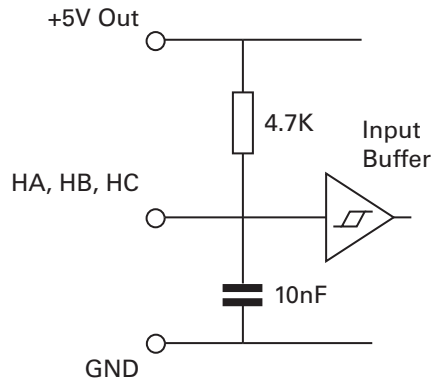

FIGURE 47. Hall sensor inputs equivalent circuit

Hall sensors can typically be powered over a wide voltage range. The controller supplies 5V for powering the Hall sensors.

Hall sensor connection to the controller is done using Molex Microfit 3.0 connectors. These high quality connectors provide a reliable connection and include a lock tab for secure operation. The connector pinout is shown in the controller model's datasheet.

Important Warning

Keep the Hall sensor wires away from the motor wires. High power PWM switching on the motor leads will induce spikes on the Hall sensor wires if located too close. On hub motors where the Hall sensor wires are inside the same cable as the motor power wires, separate the two sets of wires the nearest from the motor as possible.

Important Notice

Make sure that the motor sensors have a digital output with the signal either at 0 or at 1, as usually is the case. Sensors that output a slow changing analog signals will cause the motor to run imperfectly.

Hall Sensor Wiring Order

The order of the Hall sensors and these of the motor connections must match in order for the motor to spin. Unfortunately, there is no standard naming and ordering convention for brushless motors. It often is the case that the motor will correctly operate when wiring the

controller's sensor inputs HA, HB, HC, and the controller's U, V, W outputs in the same order as what is marked the motor or leads (if such an order is provided).

If this is not the case, then the wire order must be determined by trial and error. To do this, you can either connect the motor wires permanently and then try different combination of Hall sensor wiring, or you can connect the Hall sensors permanently and try different combinations of motor wiring. There is a total of 6 possible combinations of wiring three sensors on three controller inputs. There are also 6 possible combinations of wiring three motor wires on three controller outputs. Only one of the 6 combinations will work correctly and smoothly while allowing the controller to drive the motor in both directions.

Try the different combinations while applying a low amount of power (5 to 10%). Applying too high power may trigger the stall protection (see below). Be careful not to have the motor output wires touch each other and create a short circuit. Once a combination that make the motor spin is found, increase the power level and verify that rotation is smooth, at very slow speed and at high speed and in both directions.

Important Notice

Beware that while only one combination is valid, there may be other combinations that will cause the motor to spin. When the motor spins with the wrong wiring combination, it will do so very inefficiently. Make sure that the motor spins equally smoothly in both directions. Try all 6 combinations and select the best.

Brushless Motor Operation

Once the Hall sensors and motor power wires are correctly connected to the controller, a brushless motor can be operated exactly like a DC motor and all other sections in this manual are applicable. In addition, the Hall sensors, provide extra information about the motor's state compared to DC motors. This information enables the additional features discussed below.

Stall Detection

The Hall sensors can be used to detect whether the motor is spinning or not. The controller includes a safety feature that will stop the motor power if no rotation is detected while a given amount of power is applied for a certain time. Three combinations of power and time are available:

- 250ms at 10% power
- 500ms at 25% power
- 1s at 50% power

If the power applied is higher than the selected value and no motion is detected for the corresponding amount of time, the power to the motor is cut until the motor command is returned to 0. This function is controlled by the BLSTD - Brushless Stall Detection parameter (see "BLSTD - Brushless Stall Detection" on page 213). **Do not disable the stall protection.**

A stall condition is indicated with the "Stall" LED on the Roborun PC utility screen.

Speed Measurement using Hall Sensors

The Hall sensor information is used by the controller to compute the motor's rotation speed. Speed is determined by measuring the time between Hall sensor transitions. This measurement method is very accurate, but requires that the motor be well constructed and that the placement between sensors be accurate. On precision motors, this results in a stable speed being reported. On less elaborate motors, such as hub motors, the reported speed may oscillate by a few percents.

The motor's number of poles must be entered as a controller parameter in order to produce an accurate RPM value. See discussion above. The speed information can then be used as feedback in a closed loop system. Motor with a more precise Hall sensor positioning will work better in such a configuration than less precise motors.

If the reported speed is negative when the slider is moved in the positive direction, you can correct this by putting a negative number of poles in the motor configuration. This will be necessary in order to operate the motor in closed loop speed mode using hall sensor speed capture.

Distance Measurement using Hall Sensors

The controller automatically detects the direction of rotation, keeps track of the number of Hall sensor transition and updates a 32-bit up/down counter. The number of counts per revolution is computed as follows:

$$\text{Counts per Revolution} = \text{Number of Poles} * 6$$

The counter information can then be read via the Serial/USB port or can be used from a MicroBasic script. The counter can also be used to operate the brushless motor in a Closed Loop Position mode, within some limits.

SECTION 8

Closed Loop Speed Mode

This section discusses the controller's Closed Loop Speed mode.

Mode Description

In this mode, an analog or digital speed sensor measures the actual motor speed and compares it to the desired speed. If the speed changes because of changes in load, the controller automatically compensates the power output. This mode is preferred in precision motor control and autonomous robotic applications.

The controller incorporates a full-featured Proportional, Integral, Differential (PID) control algorithm for quick and stable speed control.

The closed loop speed mode and all its tuning parameters may be selected individually for each motor channel.

Tachometer or Encoder Wiring

Digital Optical Encoders may be used to capture accurate motor speed. This capability is only available on controllers fitted with the optional encoder module.

Analog tachometers are another technique for sensing speed. See "Connecting Tachometer to Analog Inputs" on page 47

Tachometer or Encoder Mounting

Proper mounting of the speed sensor is critical for an effective and accurate speed mode operation. Figure 48 shows a typical motor and tachometer or encoder assembly.

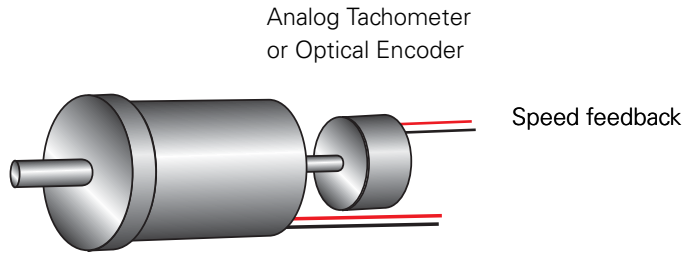

FIGURE 48. Motor and speed sensor assembly needed for Close Loop Speed mode

Tachometer wiring

The tachometer must be wired so that it creates a voltage at the controller’s analog input that is proportional to rotation speed: 0V at full reverse, +5V at full forward, and 0 when stopped.

Connecting the tachometer to the controller is as simple as shown in the diagram below.

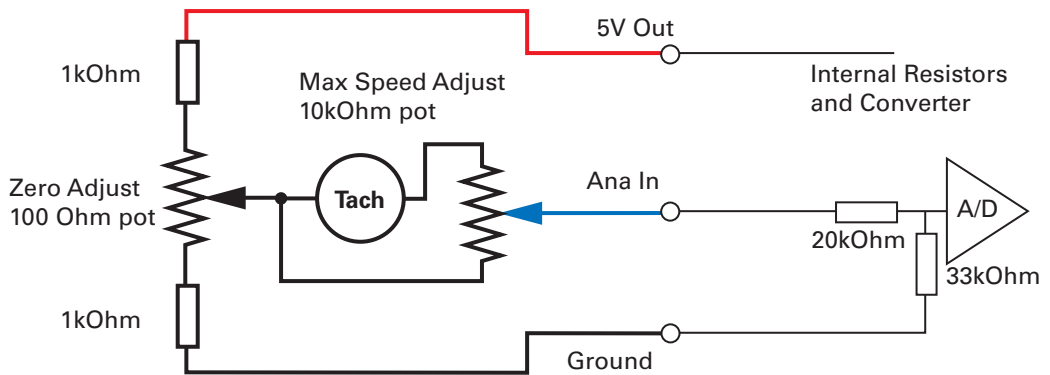

FIGURE 49. Tachometer wiring diagram

Brushless Hall Sensors as Speed Sensors

On brushless motor controllers, the Hall Sensors that are used to switch power around the motor windings, are also used to measure speed and distance travelled.

Speed is evaluated by measuring the time between transition of the Hall Sensors. A 32 bit up/down counter is also updated at each Hall Sensor transition.

Speed information picked up from the Hall Sensors can be used for closed loop speed operation without any additional hardware.

Speed Sensor and Motor Polarity

The tachometer or encoder polarity (i.e. which rotation direction produces a positive or negative speed information) is related to the motor's rotation speed and the direction the motor turns when power is applied to it.

In the Closed Loop Speed mode, the controller compares the actual speed, as measured by the tachometer, to the desired speed. If the motor is not at the desired speed and direction, the controller will apply power to the motor so that it turns faster or slower, until reached.

Important Warning

The tachometer's polarity must be such that a positive voltage is generated to the controller's input when the motor is rotating in the forward direction. If the polarity is inverted, this will cause the motor to run away to the maximum speed as soon as the controller is powered and eventually trigger the closed loop error and stop. If this protection is disabled, there will be no way of stopping it other than pressing the emergency stop button or disconnecting the power.

Determining the right polarity is best done experimentally using the Roborun utility (see "Using the Roborun Configuration Utility" on page 225) and following these steps:

1. Configure the controller in Open Loop Mode using the PC utility. This will cause the motor to run in Open Loop for now.
2. Configure the sensor you plan to use as speed feedback. If an analog tachometer is used, map the analog channel on which it is connected as "Feedback" for the selected motor channel. If an encoder is used, configure the encoder channel with the encoder's Pulses Per Revolution value.
3. Click on the Run tab of the PC utility. Configure the Chart recorder to display the speed information if an encoder is used. Display Feedback if an analog sensor is used.
4. Verify that the motor sliders are in the "0" (Stop) position.
5. If a tachometer is used, verify that the reported feedback value read is 0 when the motors are stopped. If not, adjust the Analog Center parameter.
6. Move the cursor of the desired motor to the right so that the motor starts rotating, and verify that a positive speed is reported. Move the cursor to the left and verify that a negative speed is reported.
7. If the tachometer or encoder polarity is the same as the applied command, the wiring is correct.
8. If the tachometer polarity is opposite of the command polarity, then reverse the motor's wiring, reverse the tachometer wires, or change the capture polarity in the Input configuration. If an encoder is used, swap its ChA and ChB outputs. Alternatively, swap the motor leads if using a brushed DC motor only.
9. Set the controller operating mode to Closed Loop Speed mode using the Roborun utility.
10. Move the cursor and verify that speed stabilizes at the desired value. If speed is unstable, tune the PID values.

Important Warning

It is critically important that the tachometer or encoder wiring be extremely robust. If the speed sensor reports an erroneous speed or no speed at all, the controller will consider that the motor has not reached the desired speed value and will gradually increase the applied power to the motor until the closed loop error is triggered and the motor is then stopped.

Controlling Speed in Closed Loop

When using encoder feedback or Hall Sensor (brushless motor) feedback, the controller will measure and report speed as the motor's actual RPM value.

When using analog or pulse as input command, the command value will range from 0 to +1000 and 0 to -1000. In order for the max command to cause the motor to reach the desired actual max RPM, an additional parameter must be entered in the encoder or brushless configuration. The Max RPM parameter is the speed that will be reported as 1000 when reading the speed in relative mode. Max RPM is also the speed the controller will attempt to reach when a max command of 1000 is applied.

When sending a speed command via serial or USB, the command may be sent as a relative speed (0 to +/-1000) or actual RPM value.

Control Loop Description

The controller performs the Closed Loop Speed mode using a full featured Proportional, Integral and Differential (PID) algorithm. This technique has a long history of usage in control systems and works on performing adjustments to the Power Output based on the difference measured between the desired speed (set by the user) and the actual position (captured by the tachometer).

Figure 50 shows a representation of the PID algorithm. Every 1 millisecond, the controller measures the actual motor speed and subtracts it from the desired position to compute the speed error.

The resulting error value is then multiplied by a user selectable Proportional Gain. The resulting value becomes one of the components used to command the motor. The effect of this part of the algorithm is to apply power to the motor that is proportional with the difference between the current and desired speed: when far apart, high power is applied, with the power being gradually reduced as the motor moves to the desired speed.

A higher Proportional Gain will cause the algorithm to apply a higher level of power for a given measured error thus making the motor react more quickly to changes in commands and/or motor load.

The Differential component of the algorithm computes the changes to the error from one 1 ms time period to the next. This change will be a relatively large number every time an abrupt change occurs on the desired speed value or the measured speed value. The value of that change is then multiplied by a user selectable Differential Gain and added to the output. The effect of this part of the algorithm is to give a boost of extra power when starting the motor due to changes to the desired speed value. The differential component will also greatly help dampen any overshoot and oscillation.

The Integral component of the algorithm performs a sum of the error over time. This component helps the controller reach and maintain the exact desired speed when the error is reaching zero (i.e. measured speed is near to, or at the desired value).

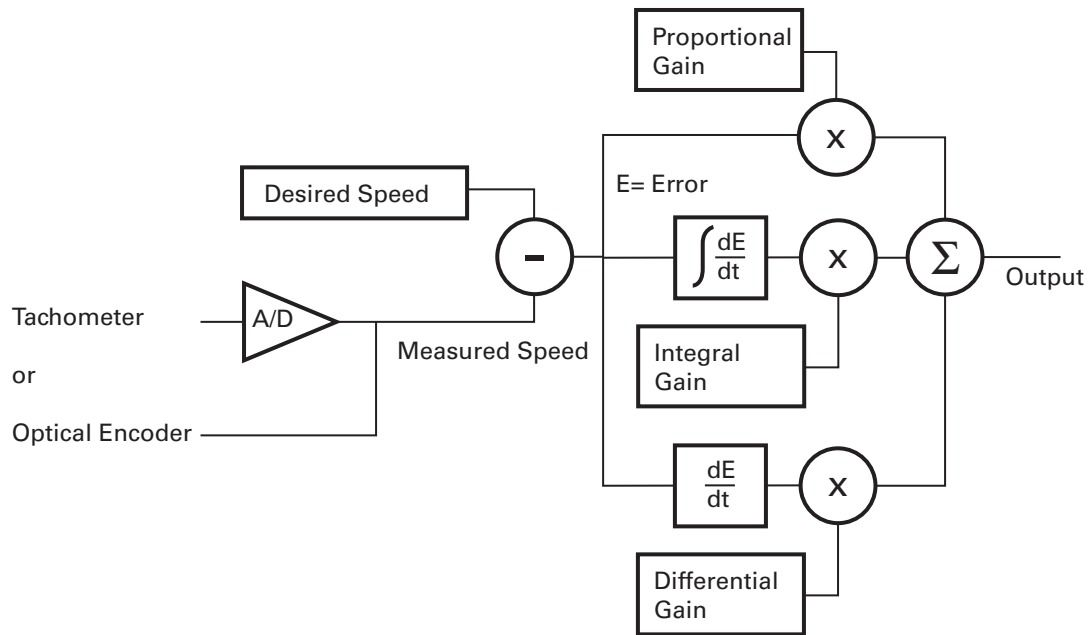

FIGURE 50. PID algorithm used in Speed mode

PID tuning in Speed Mode

As discussed above, three parameters - Proportional Gain, Integral Gain, and Differential Gain - can be adjusted to tune the Closed Loop Speed control algorithm. The ultimate goal in a well tuned PID is a motor that reaches the desired speed quickly without overshoot or oscillation.

Because many mechanical parameters such as motor power, gear ratio, load and inertia are difficult to model, tuning the PID is essentially a manual process that takes experimentation.

The Roborun PC utility makes this experimentation easy by providing one screen for changing the Proportional, Integral and Differential gains and another screen for running and monitoring the motor. First, run the motor with the preset values. Then experiment with different values until a satisfactory behavior is found.

In Speed Mode, the Integral component of the PID is the most important and must be set first. The Proportional and Differential components will help improve the response time and loop stability.

Try initially to only use a small value of I and no P or D:

P = 0
 I = 1
 D = 0

These values practically always work, but they may cause the motor to be slow reaching the desired speed. Experiment then with adding P gain, and different values of I.

In the case where the load moved by the motor is not fixed, tune the PID with the minimum expected load and tune it again with the maximum expected load. Then try to find values that will work in both conditions. If the disparity between minimal and maximal possible loads is large, it may not be possible to find satisfactory tuning values.

Note that the controller uses one set of Proportional, Integral and Differential Gains for both motors and therefore assumes that similar motor, mechanical assemblies and loads are present at each channel.

In slow systems, use the integrator limit parameter to prevent the integrator to reach saturation prematurely and create overshoots.

Error Detection and Protection

The controller will detect large tracking errors due to mechanical or sensor failures, and shut down the motor in case of problem in closed loop speed or position system. The detection mechanism looks for the size of the tracking error (desired position vs. actual position) and the duration the error is present. Three levels of sensitivity are provided in the controller configuration:

- 1: 250ms and Error > 100
- 2: 500ms and Error > 250
- 3: 1000ms and Error > 500

When an error is triggered, the motor channel is stopped until the error has disappeared, the motor channel is reset to open loop mode.

The loop error value can be monitored in real time using the Roborun PC utility.

SECTION 9

Closed Loop Relative and Tracking Position Modes

This section describes the controller's Position Relative and Position Tracking modes, how to wire the motor and position sensor assembly and how to tune and operate the controller in these modes.

Modes Description

In these two position modes, the axle of a geared-down motor is coupled to a position sensor that is used to compare the angular position of the axle versus a desired position. The controller will move the motor so that it reaches this position.

This feature makes it possible to build ultra-high torque "jumbo servos" that can be used to drive steering columns, robotic arms, life-size models and other heavy loads.

The two position modes are similar and differ as follows:

Position Relative Mode

The controller accepts a command ranging from -1000 to +1000, from serial/USB, analog joystick, or pulse. The controller reads a position feedback sensor and converts the signal into a -1000 to +1000 feedback value at the sensor's min and max range respectively. The controller then moves the motor so that the feedback matches the command, using a controlled acceleration, set velocity and controlled deceleration. This mode requires several settings to be configured properly but results in very smoothly controlled motion.

Position Tracking Mode

This mode is identical to the Position Relative mode in the way that commands and feedback are evaluated. However, the controller will move the motor simply using a PID comparing the command and feedback, without controlled acceleration and as fast as possible.

This mode requires fewer settings but often results in a motion that is not as smooth and harder to control overshoots.

Selecting the Position Modes

The two position modes are selected by changing the Motor Control parameter to Closed Loop Position. This can be done using the corresponding menu in the Power Output tree in the Roborun utility. It can also be done using the associated serial (RS232/USB) command. See “MMOD” on page 220. The position mode can be set independently for each channel.

Position Feedback Sensor Selection

The controller may be used with the following kinds of sensors:

- Potentiometers
- Hall effect angular sensors
- Optical Encoders

The first two are used to generate an analog voltage ranging from 0V to 5V depending on their position. They will report an absolute position information at all times.

Modern position Hall sensors output a digital pulse of variable duty cycle. These sensors provide an absolute position value with a high precision (up to 12-bit) and excellent noise immunity. PWM output sensors are directly readable by the controller and therefore are a recommended choice.

Optical encoders report incremental changes from a reference which is their initial position when the controller is powered up or reset. Before they can be used for reporting position, the motors must be moved in open loop mode until a home switch is detected and resets the counter. Encoders offer the greatest positional accuracy possible.

Sensor Mounting

Proper mounting of the sensor is critical for an effective and accurate position mode operation. Figure 51 shows a typical motor, gear box, and sensor assembly.

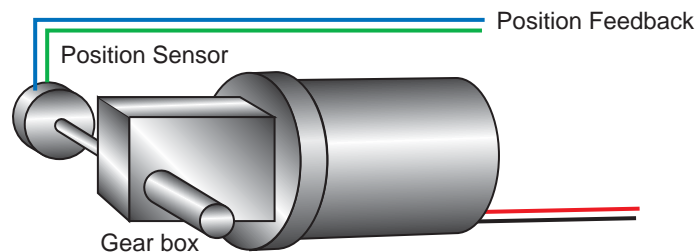

FIGURE 51. Typical motor/potentiometer assembly in Position Mode

The sensor is composed of two parts:

- a body which must be physically attached to a non-moving part of the motor assembly or the robot chassis, and
- an axle which must be physically connected to the rotating part of the motor you wish to position.

A gear box is necessary to greatly increase the torque of the assembly. It is also necessary to slow down the motion so that the controller has the time to perform the position control algorithm. If the gearing ratio is too high, however, the positioning mode will be very sluggish.

A good ratio should be such that the output shaft rotates at 1 to 10 rotations per second (60 to 600 RPM) when the motor is at full speed.

The mechanical coupling between the motor and the sensor must be as tight as possible. If the gear box is loose, the positioning will not be accurate and will be unstable, potentially causing the motor to oscillate.

Some sensors, such as potentiometers, have a limited rotation range of typically 270 degrees (3/4 of a turn), which will in turn limit the mechanical motion of the motor/potentiometer assembly. Consider using a multi-turn potentiometer as long as it is mounted in a manner that will allow it to turn throughout much of its range, when the mechanical assembly travels from the minimum to maximum position. When using encoders, best results are achieved when the encoder is mounted directly on the motor shaft.

Feedback Sensor Range Setting

Regardless the type of sensor used, feedback sensor range is scaled to a -1000 to +1000 value so that it can be compared with the -1000 to +1000 command range.

On analog and pulse sensors, the scaling is done using the min/max/center configuration parameters.

When encoders are used for feedback, the encoder count is also converted into a -1000 to +1000 range. In the encoder case, the scaling uses the Encoder Low Limit and Encoder High Limit parameters. See "Serial (RS232/USB) Operation" on page 111 for details on these configuration parameters. Beware that encoder counters produce incremental values. The encoder counters must be reset using the homing procedure before they can be used as position feedback sensors.

Important Notice

Potentiometers are mechanical devices subject to wear. Use better quality potentiometers and make sure that they are protected from the elements. Consider using a solid state hall position sensor in the most critical applications. Optical encoders may also be used, but require a homing procedure to be used in order to determine the zero position.

Important Warning

If there is a polarity mismatch, the motor will turn in the wrong direction and the position will never be reached. The motor will turn until the Closed Loop Error detection is triggered. The motor will then stop until the error disappears, the controller is set to Open Loop, or the controller is reset.

Determining the right polarity is best done experimentally using the Roborun utility (see "Using the Roborun Configuration Utility" on page 225) and following these steps:

1. Configure the controller in Open Loop Speed mode.
2. Configure the position sensor input channel as position feedback for the desired motor channel.
3. Click on the Run tab.
4. Enable the Feedback channel in the chart recorder.
5. Move the slider slowly in the positive direction and verify that the Feedback in the chart increases in value. If the Feedback value decreases, then the sensor is backwards and you should either invert it or swap the motor wires so that the motor turns in the opposite direction.
6. Move the sensor off the center position and observe the motor's direction of rotation.
7. Go to the max position and verify that the feedback value reaches 1000 a little before the end of the physical travel. Modify the min and max limits for the sensor input if needed.
8. Repeat the steps in the opposite direction and verify that the -1000 is reached a little before the end of the physical travel limit.

Important Safety Warning

Never apply a command that is lower than the sensor's minimum output value or higher than the sensor's maximum output value as the motor would turn forever trying to reach a position it cannot. Configure the Min/Max parameter for the sensor input so that a value of -1000 to +1000 is produced at both ends of the sensor travel.

Error Detection and Protection

The controller will detect large tracking errors due to mechanical or sensor failures, and shut down the motor in case of problem in closed loop speed or position system. The detection mechanism looks for the size of the tracking error (desired position vs. actual position) and the duration the error is present. Three levels of sensitivity are provided in the controller configuration:

- 1: 250ms and Error > 100
- 2: 500ms and Error > 250
- 3: 1000ms and Error > 500

When an error is triggered, the motor channel is stopped until the error has disappeared, the motor channel is reset to open loop mode.

The loop error can be monitored in real time using the Roborun PC utility.

Adding Safety Limit Switches

The Position mode depends on the position sensor providing accurate position information. If the sensor is damaged or one of its wires is cut, the motor may spin continuously in an attempt to reach a fictitious position. In many applications, this may lead to serious mechanical damage.

To limit the risk of such breakage, it is recommended to add limit switches that will cause the motor to stop if unsafe positions have been reached independent of the sensor reading. Any of the controller's digital inputs can be used as a limit switch for any motor channel.

An alternate method is shown in Figure 52. This circuit uses Normally Closed limit switches in series on each of the motor terminals. As the motor reaches one of the switches, the lever is pressed, cutting the power to the motor. The diode in parallel with the switch allows the current to flow in the reverse position so that the motor may be restarted and moved away from that limit.

The diode polarity depends on the particular wiring and motor orientation used in the application. If the diode is mounted backwards, the motor will not stop once the limit switch lever is pressed. If this is the case, reverse the diode polarity.

The diodes may be eliminated, but then it will not be possible for the controller to move the motor once either of the limit switches has been triggered.

The main benefit of this technique is its total independence on the controller's electronics and its ability to work in practically all circumstances. Its main limitation is that the switch and diode must be capable of handling the current that flows through the motor. Note that the current will flow through the diode only for the short time needed for the motor to move away from the limit switches.

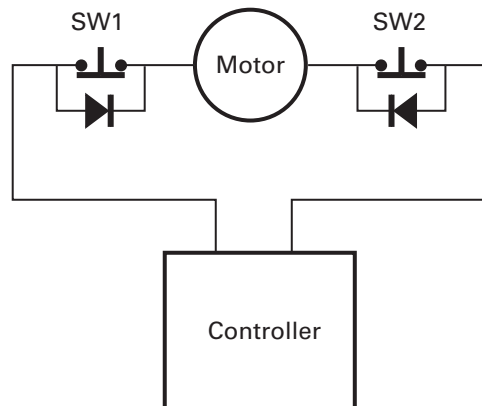

FIGURE 52. Safety limit switches interrupting power to motor

Important Warning

Limit switches must be used when operating the controller in Position Mode. This will significantly reduce the risk of mechanical damage and/or injury in case of damage to the position sensor or sensor wiring.

Using Current Trigger as Protection

The controller can be configured to trigger an action when current reaches a user configurable threshold for more than a set amount of time. This feature can be used to detect that a motor has reached a mechanical stop and is no longer turning. The triggered action can be an emergency stop or a simulated limit switch.

Operating in Closed Loop Relative Position Mode

This position algorithm allows you to move the motor from an initial position to a desired position. The motor starts with a controlled acceleration, reaches a desired velocity, and decelerates at a controlled rate to stop precisely at the end position. The graph below shows the speed and position vs. time during a position move.

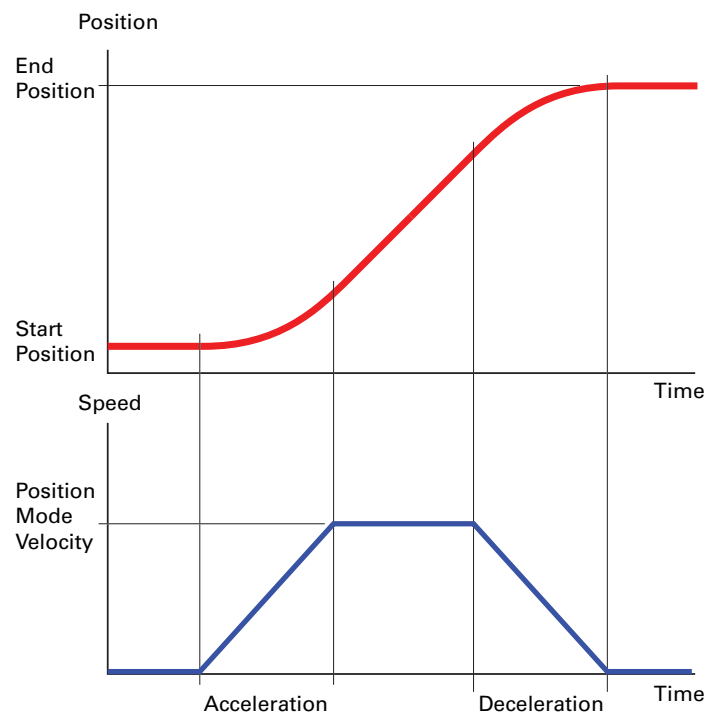

FIGURE 53.

When turning the controller on, the default acceleration, deceleration and velocity are parameters retrieved from the configuration EEPROM. In most applications, these parameters can be left unchanged and only change in commands used to control the change from one position to the other. In more sophisticated systems, the acceleration, deceleration

and velocity can be changed on the fly using Serial/USB commands or from within a MicroBasic script.

When using Encoders as feedback sensors, the controller can accurately measure the speed and the number of motor turns that have been performed at any point in time. The complete positioning algorithm can be performed with the parameters described above.

When using analog or pulse sensors as feedback, the system does not have a direct way to measure speed or number of turns. It is therefore necessary to configure an additional parameter in the controller which determines the number of motor turns between the point the feedback sensor gives the minimum feedback value (-1000) to the maximum feedback value (+1000).

In the Closed Loop Relative Position mode, the controller will compute the position at which the motor is expected to be at every millisecond in order to follow the desired acceleration and velocity profile. This computed position becomes the setpoint that is compared with the feedback sensor and a correction is applied at every millisecond.

Operating in Closed Loop Tracking Mode

In this mode the controller makes no effort to compute a smooth, millisecond by millisecond position trajectory. Instead the current feedback position is periodically compared with the requested destination and power is applied to the motor using these two values in a PID control loop.

This mode will work best if changes in the commands are smooth and not much faster than what the motor can physically follow.

Position Mode Relative Control Loop Description

The controller performs the Relative Position mode using a full featured Proportional, Integral and Differential (PID) algorithm. This technique has a long history of usage in control systems and works on performing adjustments to the Power Output based on the difference measured between the desired position (set by the user) and the actual position (captured by the position sensor).

Figure 54 shows a representation of the PID algorithm. Every 1 millisecond, the controller measures the actual motor position and subtracts it from the desired position to compute the position error.

The resulting error value is then multiplied by a user selectable Proportional Gain. The resulting value becomes one of the components used to command the motor. The effect of this part of the algorithm is to apply power to the motor that is proportional with the distance between the current and desired positions: when far apart, high power is applied, with the power being gradually reduced and stopped as the motor moves to the final position. The Proportional feedback is the most important component of the PID in Position mode.

A higher Proportional Gain will cause the algorithm to apply a higher level of power for a given measured error, thus making the motor move quicker. Because of inertia, however, a faster moving motor will have more difficulty stopping when it reaches its desired position. It will therefore overshoot and possibly oscillate around that end position.

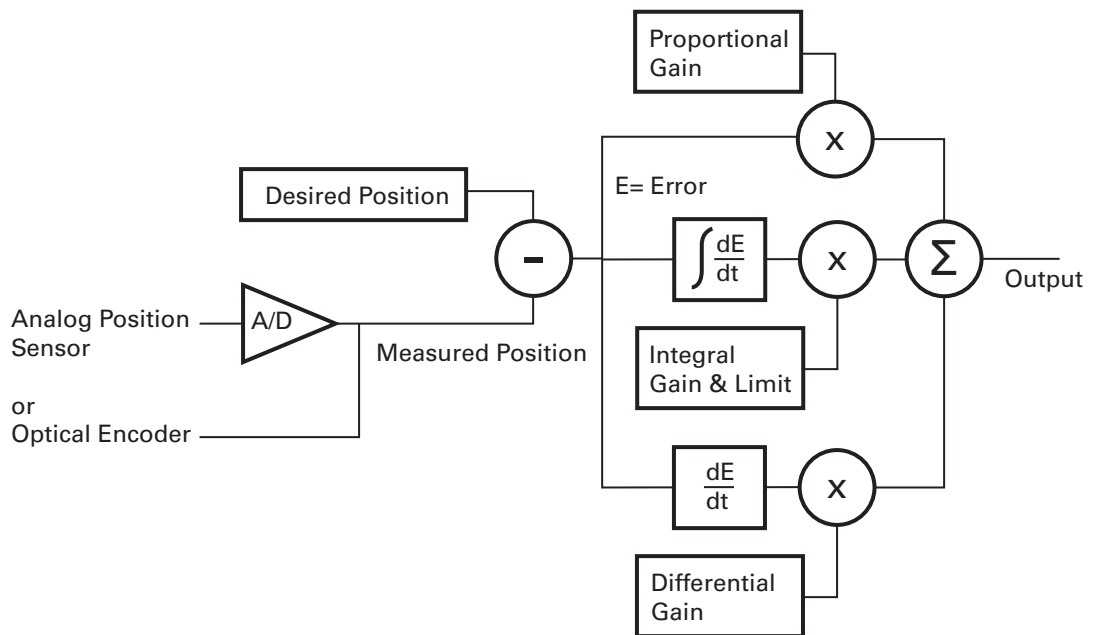

FIGURE 54. PID algorithm used in Position mode

The Differential component of the algorithm computes the changes to the error from one ms time period to the next. This change will be a relatively large number every time an abrupt change occurs on the desired position value or the measured position value. The value of that change is then multiplied by a user-selectable Differential Gain and added to the output. The effect of this part of the algorithm is to give a boost of extra power when starting the motor due to changes to the desired position value. The differential component will also help dampen any overshoot and oscillation.

The Integral component of the algorithm performs a sum of the error over time. In the position mode, this component helps the controller reach and maintain the exact desired position when the error would otherwise be too small to energize the motor using the Proportional component alone. Only a very small amount of Integral Gain is typically required in this mode.

In systems where the motor may take a long time to physically move to the desired position, the integrator value may increase significantly causing then difficulties to stop without overshoot. The Integrator Limit parameter will prevent that value from becoming unnecessarily large.

PID tuning in Position Mode

As discussed above, three parameters - Proportional Gain, Integral Gain and Differential Gain - can be adjusted to tune the position control algorithm. The ultimate goal in a well tuned PID is a motor that reaches the desired position quickly without overshoot or oscillation.

Because many mechanical parameters such as motor power, gear ratio, load and inertia are difficult to model, tuning the PID is essentially a manual process that takes experimentation.

The Roborun PC utility makes this experimentation easy by providing one screen for changing the Proportional, Integral and Differential gains and another screen for running and monitoring the motor.

When tuning the motor, first start with the Integral and Differential Gains at zero, increasing the Proportional Gain until the motor overshoots and oscillates. Then add Differential gain until there is no more overshoot. If the overshoot persists, reduce the Proportional Gain. Add a minimal amount of Integral Gain. Further fine tune the PID by varying the gains from these positions.

To set the Proportional Gain, which is the most important parameter, use the Roborun utility to observe the three following values:

- Command Value
- Actual Position
- Applied Power

With the Integral Gain set to 0, the Applied Power should be:

$$\text{Applied Power} = (\text{Command Value} - \text{Actual Position}) * \text{Proportional Gain}$$

Experiment first with the motor electrically or mechanically disconnected and verify that the controller is measuring the correct position and is applying the expected amount of power to the motor depending on the command given.

Verify that when the Command Value equals the Actual Position, the Applied Power equals to zero. Note that the Applied Power value is shown without the sign in the PC utility.

In the case where the load moved by the motor is not fixed, the PID must be tuned with the minimum expected load and tuned again with the maximum expected load. Then try to find values that will work in both conditions. If the disparity between minimal and maximal possible loads is large, it may not be possible to find satisfactory tuning values.

Note that the controller uses one set of Proportional, Integral and Differential Gains for both motors, and therefore assumes that similar motor, mechanical assemblies and loads are present at each channel.

PID Tuning Differences between Position Relative and Position Tracking

The PID works the same way in both modes in that the desired position is compared to the actually measured position.

In the Closed Loop Relative mode, the desired position is updated every ms and so the PID deal with small differences between the two values.

In the Closed Loop Tracking mode, the desired position is changed whenever the command is changed by the user.

Tuning for both modes requires the same steps. However, the P, I and D values can be expected to be different in one mode or the other.

SECTION 10

Closed Loop Count Position Mode

In the Closed Loop Position mode, the controller can move a motor a precise number of encoder counts, using a predefined acceleration, constant velocity, and deceleration. This mode requires that an encoder be mounted on the motor.

Preparing and Switching to Closed Loop

To enter this mode you will first need to configure the encoder so that it is used as feedback for motor1, and feedback for motor2 on the other encoder in a dual motor system.

Use the PC Utility to set the default acceleration, deceleration and position mode velocity in the motor menu. These values can then be changed on the fly if needed.

While in Open Loop, enable the Speed channel in the Roborun Chart recorder. Move the slider in the positive direction and verify that the measured speed polarity is also positive. If a negative speed is reported, swap the two encoder wires to change the measured polarity, or swap the motor leads to make the motor spin in the opposite direction.

Then use the PC Utility to select the Closed Loop Position Mode. After saving to the controller, the motor will operate in Closed Loop and will attempt to go to the 0 counter position. Beware therefore that the motor has not already turned before switching to Closed Loop. Reset the counter if needed prior to closing the loop.

Count Position Commands

Moving the motor is done using a set of simple commands.

To go to an absolute encoder position value, use the **!P** command:

Syntax: **!P [nn] mm**

Where: **nn** = motor channel
mm = absolute count position

Example: **!P 1 10000** will get the motor to move to absolute counter position 10000 with a smooth ramp up and down so that the motor gently stops at count 10000.

To go to a relative encoder position count that is relative to the current position, use the **!PR** command.

Syntax: **!PR [nn] cc**

Where: **nn** = motor channel
cc = relative count position

Example: Sending **!PR 1 1000** repeatedly will cause the motor to move an additional 10000 count every time. Beware that this will work until you reach the maximum counter value of +/-2,000,000 at which point the counter will rollover.

Note: Note that if a **!PR** command is sent while a previous goto position command is in progress, the value is being added to the current destination. For example, if the motor is stopped at position 0, sending **!PR 1 10000** three times rapidly will cause the motor to go directly to position 30000.

At any time you can change the acceleration and deceleration using the **!AC** and **!DC** commands:

Syntax: **!AC [nn] mm**
!DC [nn] mm

Where: **nn** = motor channel
mm = acceleration/deceleration in RPM/s*10

Example: **!AC 1 10000** = acceleration for channel 1 is 1000 RPM/s

The velocity can also be changed at any time using the **!S** command:

Syntax: **!S [nn] mm**

Where: **nn** = motor channel
mm = velocity in RPM

Position Command Chaining

It is possible to chain position commands in order to create seamless motion to a new position after an initial position is reached. To do this, the controller can store the next goto position with, optionally, a new set of acceleration, deceleration and velocity values.

The commands that set the "next" move are identical to these discussed in the previous section, with the addition of an "X" at the end. The full command list is:

!PX nn mm Next position absolute

!PRX nn mm Next position relative

!ACX nn mm Next acceleration

!DCX nn mm Next deceleration

!SX Next velocity

Example: **!PX 1 -50000** will cause the motor to move to that new destination once the previous destination is reached. **!PRX -10000** will cause the motor to move 10000 count back from the previous end destination. If the next acceleration, next deceleration or next velocity are not entered, the value(s) used for the previous motion will be used.

Beware that the next commands must be entered while the motor is moving, since the next commands will only be taken into account at the end of the current motion.

To chain more than two commands, use a MicroBasic script or an external program to load new "next" command when the previous "next" commands become active. The **?DR** query can be used to detect that this transition has occurred and that a new next command can be sent to the controller.

PID Tunings

To move with the desired motion profile, the microcomputer onboard the controller computes the exact position the motor is expected to be at every 1ms. Then, a PID control loop adjusts the power to the motor so that the motor is precisely at the desired counter value at every millisecond interval. As long as the motor assembly can physically reach the acceleration and velocity, smooth motion will result with relatively little need for tuning. As for any position control loop, the dominant PID parameter is the Proportional gain with only little Integral gain and smaller or no Derivative gain. See "PID tuning in Position Mode" on page 100.

SECTION 11

Closed Loop Torque Mode

This section describes the controller's operation in Torque Mode.

Torque Mode Description

The torque mode is a special case of closed loop operation where the motor command controls the current that flows through the motor regardless of the motor's actual speed.

In an electric motor, the torque is directly related to the current. Therefore, controlling the current controls the torque.

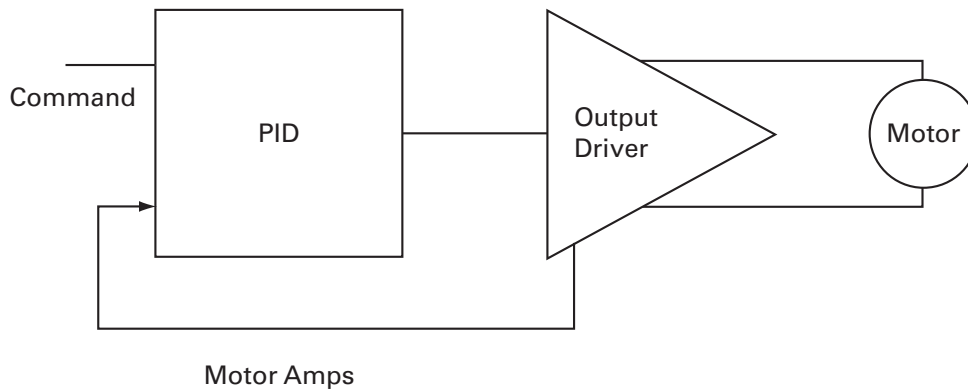

FIGURE 55. Torque mode

Torque mode is mostly used in electric vehicles since applying a higher command gives more "push"; similarly to how a gas engine would respond to stepping on a pedal. Likewise, releasing the throttle will cause the controller to adjust the power output so that the zero amps flow through the motor. In this case, the motor will coast and it will take a negative command (i.e. negative amps) to brake the motor to a full stop.

Torque Mode Selection, Configuration and Operation

Use the PC utility and the menu "Operating Mode" to select Torque Mode. The controller will now use user commands from RS232, USB, Analog or Pulse to command the motor current.

Commands are ranging from -1000 to +1000. The command is then scaled using the amps limit configuration value.

For example, if the amps limit is set to 100A, a user command of 500 will cause the controller to energize the motor until 50A are measured. If the motor is little loaded and the desired current cannot be reached, the motor will run at full speed.

Torque Mode Tuning

In Torque Mode, the measured Motor Amps become the feedback in the closed loop system. The PID then operates the same way as in the other Closed Loop modes described in this manual (See "PID tuning in Position Mode" on page 100).

In most applications requiring torque mode, the loop response does not need to be very quick and good results can be achieved with a wide range of PID gains. The P and I gains are the primary component of the loop in this mode. Perform a first test using $P=2$, $I=1$ and $D=0$, and then adjust the I and P gain as needed until satisfactory results are reached.

Configuring the Loop Error Detection

In Torque Mode, it is very likely that the controller will encounter situation where the motor is not sufficiently loaded in order to reach the desired amps. In this case, controller output will quickly rise to 100% while a significant Loop Error (i.e. desired amps - measured amps) is present. In the default configuration, the controller will shut down the power if a large loop error is present for more than a preset amount of time. This safety feature should be disabled in most systems using Torque Mode.

Torque Mode Limitations

The torque mode uses the Motor Amps and not the Battery Amps. See "Battery Current vs. Motor Current" on page 28. In all Roboteq controllers except the Separate Excitation models, Battery Amps is measured and Motor Amps is estimated. The estimation is fairly accurate at power level of 20% and higher. Its accuracy drops below 20% of PWM output and no motor current is measured at all when the power output level is 0%, even though current may be flowing in the motor, as it would be the case if the motor is pushed. The torque mode will therefore not operate with good precision at low power output levels.

Furthermore the resolution of the amps capture is limited to around 0.5% of the full range. On high current controller models, for example, amps are measured with 500mA increments. If the amps limit is set to 100A, this means the torque will be adjustable with a 0.5% resolution. If on the same large controller the amps limit is changed to 10A, the torque will be adjustable with the same 500mA granularity which will result in 5% resolution. For best results use an amps limit that is at least 50% than the controller's max rating.

Torque Mode Using an External Amps Sensor

The limitations described above can be circumvented using an external amps sensor device such as the Allegro Microsystems ACS756 family of hall sensors. These inexpensive devices can be inserted in series with one of the motor leads while connected to one of the controller's analog inputs. Since it is directly measuring the real motor amps, this sensor will provide accurate current information in all load and regeneration conditions.

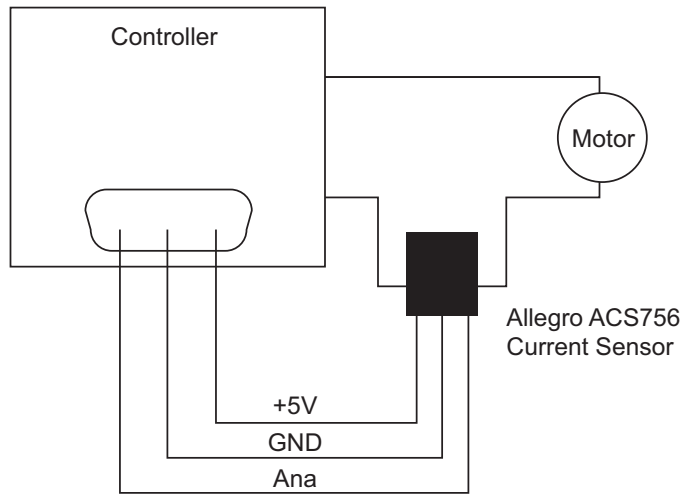

FIGURE 56. Torque external sensor

To operate in torque mode, simply configure the selected analog input range to this of the sensor's output at the min and max current that will correspond to the -1000 to +1000 command range. Configure the analog input as feedback for the selected motor channel. Then operate the controller in Position Tracking Mode (See "Position Tracking Mode" on page 93). While the controller will not actually be tracking position, it will adjust the output based on the command and sensor feedback exactly in the same fashion.

SECTION 12

Serial (RS232/ USB) Operation

This section describes the communication settings of the controller operating in the RS232 or USB mode. This information is useful if you plan to write your own controlling software on a PC or microcomputer.

The full set of commands accepted by the controller is provided in “Commands Reference” on page 163.

If you wish to use your PC simply to set configuration parameters and/or to exercise the controller, you should use the RoborunPlus PC utility.

Use and benefits of Serial Communication

The serial communication allows the controller to be connected to microcomputers or wireless modems. This connection can be used to both send commands and read various status information in real-time from the controller. The serial mode enables the design of complex motion control system, autonomous robots or more sophisticated remote controlled robots than is possible using the RC mode. RS232 commands are very precise and securely acknowledged by the controller. They are also the method by which the controller’s features can be accessed and operated to their fullest extent.

When operating in RC or analog input, serial communication can still be used for monitoring or telemetry.

When connecting the controller to a PC, the serial mode makes it easy to perform simple diagnostics and tests, including:

- Sending precise commands to the motor
- Reading the current consumption values and other parameters
- Obtaining the controller’s software revision and date
- Reading inputs and activating outputs
- Setting the programmable parameters with a user-friendly graphical interface
- Updating the controller’s software

Serial Port Configuration

The controller's serial communication port is set as follows:

- 115200 bits/s
- 8-bit data
- 1 Start bit
- 1 Stop bit
- No Parity

Communication is done without flow control, meaning that the controller is always ready to receive data and can send data at any time.

These settings cannot be changed. You must therefore adapt the communication settings in your PC or microcomputer to match those of the controller.

Connector RS232 Pin Assignment



FIGURE 57. DB25 and DB15 Connector pin locations

When used in the RS232 mode, the pins on the controller's DB15 or DB25 connector (depending on the controller model) are mapped as described in the table below

TABLE 10. RS232 Signals on DB15 and DB25 connectors

Pin Number	Input or Output	Signal	Description
2	Output	Data Out	RS232 Data from Controller to PC
3	Input	Data In	RS232 Data In from PC
5	-	Ground	Controller ground

Cable configuration

The RS232 connection requires the special cabling as described in Figure 58. The 9-pin female connector plugs into the PC (or other microcontroller). The 15-pin or 25-pin male connector plugs into the controller.

It is critical that you do not confuse the connector's pin numbering. The pin numbers on the drawing are based on viewing the connectors from the front. Most connectors brands have pin numbers molded on the plastic.

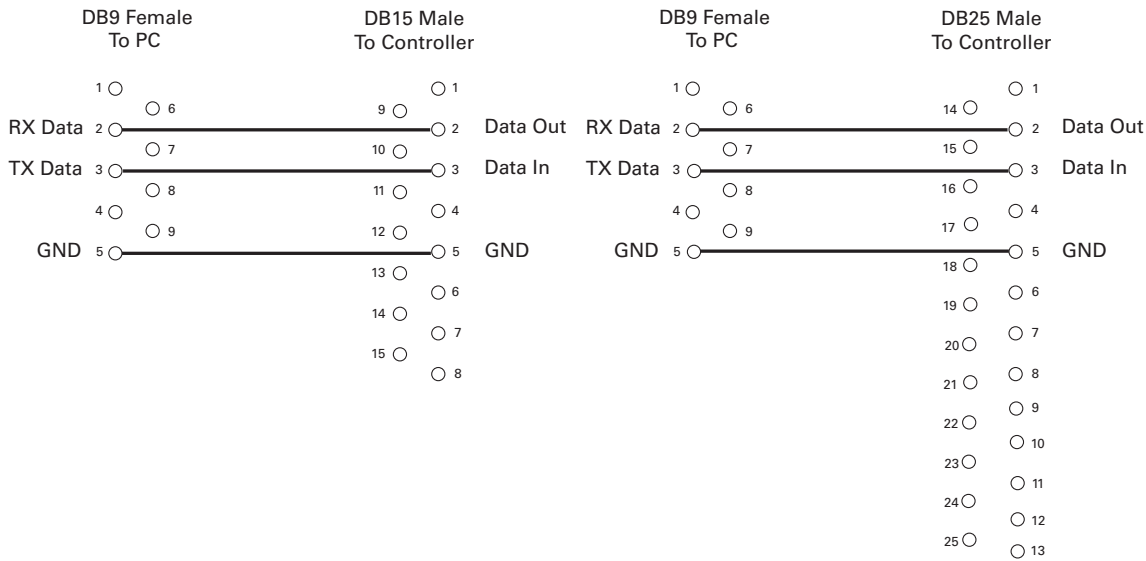

FIGURE 58. PC to controller RS232 cable/connector wiring diagram

The 9 pin to 15 pin cable is provided by Roboteq for controllers with 15 pin connectors.

Controllers with 25 pins connectors are fitted with a USB port that can be used with any USB cables with a type B connector.

Extending the RS232 Cable

RS232 extension cables are available at most computer stores. However, you can easily build one using a 9-pin DB9 male connector, a 9-pin DB9 female connector and any 3-conductor cable. **DO NOT USE COMMERCIAL 9-PIN TO 25-PIN CONVERTERS** as these do not match the 25-pin pinout of the controller. These components are available at any electronics distributor. A CAT5 network cable is recommended, and cable length may be up to 100' (30m). Figure 59 shows the wiring diagram of the extension cable.

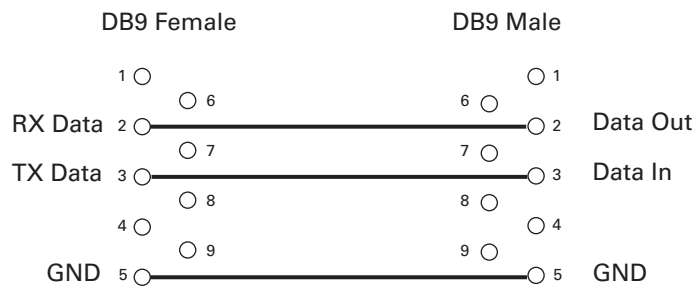

FIGURE 59. RS232 extension cable/connector wiring diagram

USB Configuration

USB is available on some controller models and provides a fast and reliable communication method between the controller and the PC. After plugging the USB cable to the controller and the PC, the PC will detect the new hardware, and install the driver. Upon successful installation, the controller will be ready to use.

The controller will appear like another Serial device to the PC. This method was selected because of its simplicity, particularly when writing custom software: opening a COM port and exchanging serial data is a well documented technique in any programming language.

Note that Windows will assign a COM port number that is more or less random. The Robo-run PC utility automatically scans all open COM ports and will detect the controller on its own. When writing your own software, you will need to account for this uncertainty in the COM port assignment.

Important Warning

Beware that because of its sophistication, the USB protocol is less likely to recover than RS232 should an electrical disturbance occur. We recommend using USB for configuration and monitoring, and use RS232 for field deployment. Deploy USB based system only after performing extensive testing and verifying that it operates reliably in your particular environment.

Command Priorities

The controller will respond to commands from one of three or four possible sources:

- Serial (RS232 or USB)
- Pulse
- Analog
- Spektrum Radio (when available)

One, two, three or all four command modes can be enabled at the same time. When multiple modes are enabled, the controller will select which mode to use based on a user selectable priority scheme. The priority mechanism is described in details in "Input Command Modes and Priorities" on page 55.

USB vs. Serial Communication Arbitration

Commands may arrive through the RS232 or the USB port at the same time. They are executed as they arrive in a first come first served manner. Commands that are arriving via USB are replied on USB. Commands arriving via the UART are replied on the UART. Redirection symbol for redirecting outputs to the other port exists (e.g. a command can be made respond on USB even though it arrived on RS232).

CAN Commands

Command arriving via CAN share the same priority as serial commands and may conflict with command arriving via serial or USB. CAN queries will not interfere with serial/USB operation.

Script-generated Commands

Commands that are issued from a user script are handled by the controller exactly as serial commands received via USB or RS232. Care must be taken that conflicting commands are not sent via the USB/serial at the same time that a different command is issued by the script.

Script commands are also subject to the serial Watchdog timer. Motors will be stopped and command input will switch according to the Priority table if the Watchdog timer is allowed to timeout.

Communication Protocol Description

The controller uses a simple communication protocol based on ASCII characters. Commands are not case sensitive. **?a** is the same as **?A**. Commands are terminated by carriage return (Hex 0x0d, '\r').

The underscore '_' character is interpreted by the controller as a carriage return. This alternate character is provided so that multiple commands can be easily concatenated inside a single string.

All other characters lower than 0x20 (space) have no effect.

Character Echo

The controller will echo back to the PC or Microcontroller every valid character it has received. If no echo is received, one of the following is occurring:

- echo has been disabled
- the controller is Off
- the controller may be defective

Command Acknowledgement

The controller will acknowledge commands in one of the two ways:

For commands that cause a reply, such as a configuration read or a speed or amps queries, the reply to the query must be considered as the command acknowledgement.

For commands where no reply is expected, such as speed setting, the controller will issue a "plus" character (+) followed by a Carriage Return after every command as an acknowledgement.

Command Error

If a command or query has been received, but is not recognized or accepted for any reason, the controller will issue a "minus" character (-) to indicate the error.

If the controller issues the "-" character, it should be assumed that the command was not recognized or lost and that it should be repeated.

Watchdog time-out

For applications demanding the highest operating safety, the controller should be configured to automatically switch to another command mode or to stop the motor (but otherwise remain fully active) if it fails to receive a valid command on its RS232 or USB ports, or from a MicroBasic Script for more than a predefined period.

By default, the watchdog is enabled with a timeout period of 1 second. Timeout period can be changed or the watchdog can be disabled by the user. When the watchdog is enabled and timeout expires, the controller will accept commands from the next source in the priority list. See "Command Priorities" on page 114.

Controller Present Check

The controller will reply with an ASCII ACK character (0x06) anytime it receives a QRY character (0x05). This feature can be used to quickly scan a serial port and detect the presence, absence or disappearance of the controller. The QRY character can be sent at any time (even in the middle of a command) and has no effect at all on the controller's normal operation.

SECTION 13

CAN Networking on Roboteq Controllers

Some controller models are equipped with a standard CAN interface allowing up to 127 controllers to work together on a single twisted pair network at speeds up to 1Mbit/s.

Supported CAN Modes

Three CAN operating modes are available on the CAN-enabled Roboteq controllers:

- 1 - RawCAN
- 2 - MiniCAN
- 3 - CANopen

RawCAN is a low-level operating mode giving read and write access to CAN frames. It is recommended for use in low data rate systems that do not obey to any specific standard. CAN frames are typically built and decoded using the MicroBasic scripting language.

MiniCAN is greatly simplified subset of CANopen, allowing, within limits, the integration of the controller into an existing CANopen network. This mode requires MicroBasic scripting to prepare and use the CAN data.

CANopen is the full Standard from CAN in Automation (CIA), based on the DS302 specification. It is the mode to use if full compliance with the CANopen standard is a primary requisite.

This section describes the RawCAN and MiniCAN modes, refer to section "CANopen Interface" on page 123 for a description of the CANopen mode.

Mode Selection and Configuration

Mode selection is done using the CAN menu in the RoborunPlus PC utility.

Common Configurations

CAN Mode:	Used to select one of the 3 operating modes. Off disables all CAN receive and transmit capabilities.
Node ID:	CAN Node ID used for transmission from the controller. Value may be between 1 and 126 included.
Bit Rate:	Selectable bit rate. Available speeds are 1000, 800, 500, 250, 125, 50, 25, 10 kbit/s. Default is 125kbit and is the recommended speed for RawCAN and MiniCAN modes.
Heartbeat:	Period at which a Heartbeat frame is sent by the controller. The frame is CANopen compatible 0x700 + NodeID, with one data byte of value 0x05 (Status: Operational). The Heartbeat is sent in any of the selected modes. It can be disabled by entering a value of 0.

MiniCAN Configurations

ListenNodeID:	Filters to accept only packets sent by a specific node.
SendRate:	Period at which data frames are sent by the controller. Frames are structured as standard CANopen Transmit Process Data Objects (TPDOs). Transmission can be disabled by entering a value of 0.

RawCAN Configurations

In the RawCAN mode, incoming frames may be filtered or not by changing the ListenNodeID parameter that is shared with the MiniCAN mode. A value of 0 will capture all incoming frames and it will be up to the user to set the ones wanted. Any other value will cause the controller to capture only frames from that sender.

Using RawCAN Mode

In the RawCAN Mode, received unprocessed data packets can be read by the user. Likewise, the user can build a packet with any content and send it on the CAN network. A FIFO buffer will capture up to 16 frames.

CAN packets are essentially composed by a header and a data payload. The header is an 11 bit number that identifies the sender's address (bits 0 to 6) and a packet type (bits 7 to 10). Data payload can be 0 to 8 bytes long.

Checking Received Frames

Received frames are first loaded in the 16-frame FIFO buffer. Before a frame can be read, it is necessary to check if any frames are present in the buffer using the **?CF** query. The query can be sent from the serial/USB port, or from a MicroBasic script using the `getValue_CF` function. The query will return the number of frames that are currently pending, and copy the oldest frame into the read buffer, from which it can then be accessed. Sending **?CF** again, copies the next frame into the read buffer.

The query usage is as follows:

Syntax: **?CF**

Reply: **CF**=number of frames pending

Reading Raw Received Frames

After a frame has been moved to the read buffer, the header, bytecount and data can be read with the **?CAN** query. The query can be sent from the serial/USB port, or from a MicroBasic script using the `getvalue(_CAN, n)` function. The query usage is as follows:

When the query is sent from serial or USB, without arguments, the controller replies by outputting all elements of the frame separated by colons.

Syntax: **?CAN [ee]**

Reply: **CAN**=header:bytecount:data0:data1: ... :data7

Where: **ee** = frame element
 1 = header
 2 = bytecount
 3 to 10 = data0 to data7

Examples: Q: **?CAN**
 R: **CAN=5:4:11:12:13:14:0:0:0**

 Q: **?CAN 3**
 R: **CAN=11**

Notes: Read the header to detect that a new frame has arrived. If header is different than 0, then a new frame has arrived and you may read the data.

 After reading the header, its value will be 0 if read again, unless a new frame has arrived.

 New CAN frames will not be received by the controller until a **?CAN** query is sent to read the header or any other element.

 Once the header is read, proceed to read the other elements of the received frame without delay to avoid data to be overwritten by a new arriving frame.

Transmitting Raw Frames

RawCAN Frames can easily be assembled and transmitted using the CAN Send Command **!CS**. This command can be used to enter the header, bytecount, and data, one element at a time. The frame is sent immediately after the bytecount is entered, and so it should be entered last.

Syntax: **!CS ee nn**

Where: **ee** = frame element
 1 = header
 2 = bytecount

3 to 10 = data0 to data7

nn = value

Examples: **!CS 1 5** Enter 5 in header
 !CS 3 2 Enter 2 in Data 0
 !CS 4 3 Enter 3 in Data 1
 !CS 2 2 Enter 2 in bytecount. Send CAN data frame

Using MiniCAN Mode

MiniCAN is greatly simplified subset of CANopen. It only supports Heartbeat, and fixed map Received Process Data Objects (RPDOs) and Transmit Process Data Objects (TPDOs). It does not support Service Data Objects (SDOs), Network Management (NMT), SYNC or other objects.

Transmitting Data

In MiniCAN mode, data to be transmitted is placed in one of the controller's available Integer or Boolean User Variables. Variables can be written by the user from the serial/USB using !VAR for Integer Variables, or !B for Boolean Variables. They can also be written from MicroBasic scripts using the setcommand(_VAR, n) and setcommand(_B, n) functions. The value of these variables is then sent at a periodic rate inside four standard CANopen TPDO frames (TPDO1 to TPDO4). Each of the four TPDOs is sent in turn at the time period defined in the SendRate configuration parameter.

Header:

TPDO1: 0x180 + NodeID
 TPDO2: 0x280 + NodeID
 TPDO3: 0x380 + NodeID
 TPDO4: 0x480 + NodeID

Data:

	Byte1	Byte2	Byte3	Byte4	Byte5	Byte6	Byte7	Byte8
TPDO1	VAR1				VAR2			
TPDO2	VAR3				VAR4			
TPDO3	VAR5		VAR6		VAR7		VAR8	
TPDO4	BVar 1-8	BVar 9-16	BVar 17-24	BVar 25-32				

Byte and Bit Ordering:

Integer Variables are loaded into a frame with the Least Significant Byte first. Example 0x12345678 will appear in a frame as 0x78 0x56 0x34 0x12.

Boolean Variables are loaded in a frame as shown in the table above, with the lowest Boolean Variable occupying the least significant bit of each byte. Example Boolean Var 1 will appear in byte as 0x01.

Receiving Data

In MiniCAN mode, incoming frames headers are compared to the Listen Node ID number. If matched, and if the other 4 bits of the header identify the frame as a CANopen standard RPDO1 to RPDO4, then the data is parsed and stored in Integer or Boolean Variables according to the map below. The received data can then be read from the serial/USB using the ?VAR or ?B queries, or they can be read from a MicroBasic script using the getvalue(_VAR, n) or getvalue(_B, n) functions.

Header:

RPDO1: 0x200 + NodeID
 RPDO2: 0x300 + NodeID
 RPDO3: 0x400 + NodeID
 RPDO4: 0x500 + NodeID

Data:

	Byte1	Byte2	Byte3	Byte4	Byte5	Byte6	Byte7	Byte8
RPDO1	VAR9				VAR10			
RPDO2	VAR11				VAR12			
RPDO3	VAR13		VAR14		VAR15		VAR16	
RPDO4	BVar 33-40	BVar 41-48	BVar 49-56	BVar 57-64				

Byte and Bit Ordering:

Integer Variables are loaded from frame with the Least Significant Byte first. Example, a frame with data as 0x78 0x56 0x34 0x12 will load in an Integer Variable as 0x12345678.

Boolean Variables are loaded from a frame as shown in the table above, with the lowest Boolean Variable occupying the least significant bit of each byte. Example a received byte of 0x01 will set Boolean Var 33 and clear Vars 34 to 40.

MiniCAN Usage Example

MiniCAN can only be used with the addition of MicroBasic scripts that will give a meaning to the general variables in which the CAN data are stored. The following simple script uses VAR1 that is transported in RPDO1 as the incoming motor command and puts the Motor Amp VAR9 so that it is sent in TPDO1.

```
top:
speed = getvalue(_VAR, 9)
setcommand(_G, 1, speed)
motor_amp = getvalue(_A, 1)
setcommand(_VAR, 1, motor_amps)
wait(10)
goto top:
```

Note: This script does not check for loss of communication on the CAN bus. It is provided for information only.

SECTION 14

CANopen Interface

This section describes the configuration of the CANopen communication protocol and the commands accepted by the controller using the CANopen protocol. It will help you to enable CANopen on your Roboteq controller, configure CAN communication parameters, and ensure efficient operation in CANopen mode.

The section contains CANopen information specific to Roboteq controllers. Detailed information on the physical CAN layer and CANopen protocol can be found in the DS301 documentation.

Use and benefits of CANopen

CANopen protocol allows multiple controllers to be connected into an extensible unified network. Its flexible configuration capabilities offer easy access to exposed device parameters and real-time automatic (cyclic or event-driven) data transfer.

The benefits of CANopen include:

- Standardized in EN50325-4
- Widely supported and vendor independent
- Highly extensible
- Offers flexible structure (can be used in a wide variety of application areas)
- Suitable for decentralized architectures
- Wide support of CANopen monitoring tools and solutions

CAN Connection

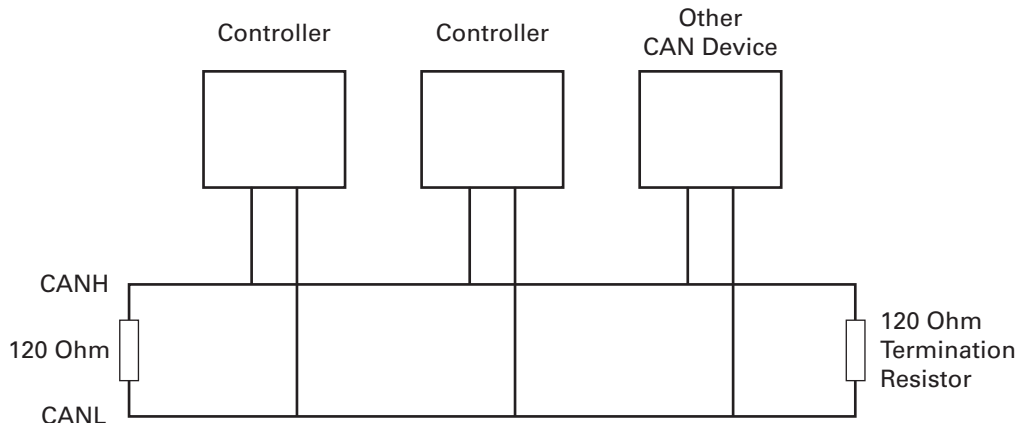

FIGURE 60. CAN connection

Connection to a CAN bus is as simple as shown on the diagram above. 120 Ohm Termination Resistors must be inserted at both ends of the bus cable. CAN network can be up to 1000m long. See CAN specifications for maximum length at the various bit rates.

CAN Bus Configuration

To configure communication parameters via the RoborunPlus PC utility, your controller must be connected to a PC via an RS232/USB port (See "Using the Roborun Configuration Utility" on page 225).

Use the CAN menu in the Configuration tab in order to enable the CANopen mode. Additionally, the utility can be used to configure the following parameters:

- Node ID
- Bit rate
- Heartbeat (ms)
- Autostart
- TPDO Enable and Send rate

Node ID

Every CANopen network device must have a unique Node ID, between 1 and 127. The value of 0 is used for broadcast messaging and cannot be assigned to a network node. The default Node ID assigned to a Roboteq motor controller is set to 1.

Bit Rate

The CAN bus supports bit rates ranging from 10Kbps to 1Mbps. The default rate used in the current CANopen implementation is set to 125kbps. Valid bit rates supported by the controller are:

- 1000K
- 800K
- 500K

- 250K
- 125K
- 50K
- 25K
- 10K

Heartbeat

A heartbeat message is sent to the bus in millisecond intervals. Heartbeats are useful for detecting the presence or absence of a node on the network. The default value is set to 1000ms.

Autostart

When autostart is enabled, the controller automatically enters the Operational Mode of CANopen. The controller autostart is enabled by default. Disabling the parameter will prevent the controller from starting automatically after the reset occurs. When disabled, the controller can only be enabled when receiving a CANopen management command.

CAN Bus Pinout

Depending on the controller model, the CAN signals are located on the 15-pin female connector or 9-pin male connector. Refer to datasheet for details.

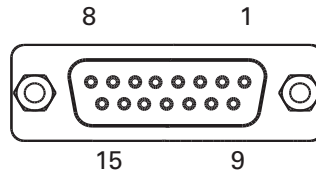

FIGURE 61. DB15 Connector pin locations

The pins on the DB15 connector are mapped as described in the table below.

TABLE 11. CAN Signals on DB15 connector

Pin Number	Signal	Description
6	CAN_L	CAN bus low
7	CAN_H	CAN bus high

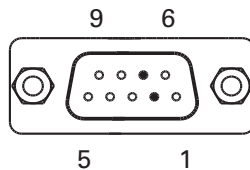

FIGURE 62. DB9 Connector pin locations

The pins on the DB9 connector are mapped as described in the table below.

TABLE 12. CAN Signals on DB9 connector

Pin Number	Signal	Description
2	CAN_L	CAN bus low
7	CAN_H	CAN bus high

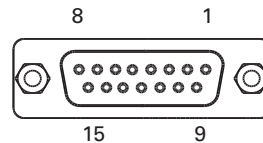

FIGURE 63. DB15 Connector pin locations

The pins on the DB15 connector are mapped as described in the table below.

TABLE 13. CAN Signals on DB15 connector

Pin Number	Signal	Description
6	CAN_L	CAN bus low
7	CAN_H	CAN bus high

CAN and USB Limitations

On most controller models CAN and USB cannot operate at the same time. On controllers equipped with a USB connector, if simultaneous connection is not allowed, the controller will enable CAN if USB is not connected.

The controller will automatically enable USB and disable CAN as soon as the USB is connected to the PC. The CAN connection will then remain disabled until the controller is restarted with the USB unplugged.

See the controller model datasheet to verify whether simultaneous CAN and USB is supported.

Important Notice

Power up the controller with the USB cable disconnected and leave disconnected in order to operate CAN.

Commands Accessible via CANopen

Practically all of the controller's real-time queries and real-time commands that can be accessed via Serial/USB communication can also be accessed via CANopen. The meaning, effect, range, and use of these commands is explained in detail in "Serial (RS232/USB) Operation" on page 111.

All supported commands are mapped in a table, or Object Dictionary that is compliant with the CANopen specification. See “Object Dictionary” on page 129 for a complete set of commands.

CANopen Message Types

The controller operating in the CANopen mode can accept the following types of messages:

- Service Data Objects, or SDO messages to read/write parameter values
- Process Data Objects, or PDO mapped messages to automatically transmit parameters and/or accept commands at runtime
- Network Management, or NMT as defined in the CANopen specification

Service Data Object (SDO) Read/Write Messages

Runtime queries and runtime commands can be sent to the controller in real-time using the expedited SDO messages.

SDO messages provide generic access to Object Dictionary and can be used for obtaining parameter values on an irregular basis due to the excessive network traffic that is generated with each SDO request and response message.

The list of commands accessible with SDO messages can be found in the “Object Dictionary” on page 129.

Transmit Process Data Object (TPDO) Messages

Transmit PDO (TPDO) messages are one of the two types of PDO messages that are used during operation.

TPDOs are runtime operating parameters that are sent automatically on a periodic basis from the controller to one or multiple nodes. TPDOs do not alter object data; they only read internal controller values and transmit them to the CAN bus.

TPDOs are identified on a CANopen network by the bit pattern in the 11-bit header of the CAN frame.

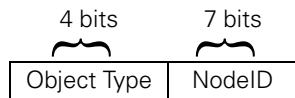

TPDO1: 0x180 + Node ID
 TPDO2: 0x280 + Node ID
 TPDO3: 0x380 + Node ID
 TPDO4: 0x480 + Node ID

CANopen allows up to four TPDOs for any node ID. TPDO1 to TPDO4 are used to transmit up to 8 user variables which may be loaded with any operating parameters using MicroBasic scripting.

Each of the 4 TPDOs can be configured to be sent at user-defined periodic intervals. This is done using the CTPS parameter (See “CTPS - CANOpen TPDO Send Rate” on page 223).

TABLE 14. Commands mapped on TPDOs

TPDO	Object Index-Sub	Size	Object Mapped
TPDO1	0x2106-1	S32	User VAR 1
	0x2106-2		User VAR 2
TPDO2	0x2106-3	S32	User VAR 3
	0x2106-4		User VAR 4
TPDO3	0x2106-5	S32	User VAR 5
	0x2106-6		User VAR 6
TPDO4	0x2106-7	S32	User VAR 7
	0x2106-8		User VAR 8
S32: signed 32-bit word			

Receive Process Data Object (RPDO) Messages

RPDOs are configured to capture runtime data destined to the controller.

RPDOs are CAN frames identified by their 11-bit header.

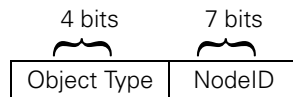

RPDO1: 0x200 + Node ID
 RPDO2: 0x300 + Node ID
 RPDO3: 0x400 + Node ID
 RPDO4: 0x500 + Node ID

Roboteq CANopen implementation supports RPDOs. Data received using RPDOs are stored in 8 user variables from where they can be processed using MicroBasic scripting.

TABLE 15. Commands mapped on RPDOs

RPDO	Object Index-Sub	Size	Object Mapped
RPDO1	0x2005-9	S32	User VAR 9
	0x2005-10		User VAR 10
RPDO2	0x2005-11	S32	User VAR 11
	0x2005-12		User VAR 12
RPDO3	0x2005-13	S32	User VAR 13
	0x2005-14		User VAR 14
RPDO4	0x2005-15	S32	User VAR 15
	0x2005-16		User VAR 16
S32: signed 32-bit word			

Object Dictionary

The CANopen dictionary shown in this section is subject to change. Please contact Roboteq technical support for the latest Object Dictionary.

The Object Dictionary given in the table below contains the runtime queries and runtime commands that can be accessed with SDO/PDO messages during controller operation.

TABLE 16. Object Dictionary

Index	Sub	Entry Name	Data Type & Access	Command Reference & Page
Runtime Commands				
0x2001	01	Set Position, ch.1	S32 WO	"P", page 169
	02	Set Position, ch.2		
0x2002	01	Set Velocity, ch.1	S16 WO	"S", page 171
	02	Set Velocity, ch.2		
0x2003	01	Set Encoder Counter, ch.1	S32 WO	"C", page 166
	02	Set Encoder Counter, ch.2		
0x2004	01	Set Brushless Counter, ch.1	S32 WO	"CB", page 166
	02	Set Brushless Counter, ch.2		
0x2005	01	Set User Integer Variable 1	S32 WO	"VAR", page 171
	02	Set User Integer Variable 2		
	...			
	06	Set User Integer Variable 6		
	07	Set User Integer Variable 7		
	08	Set User Integer Variable 8		
	09	Set User Integer Variable 9		
	A	Set User Integer Variable 10		
	B	Set User Integer Variable 11		
	C	Set User Integer Variable 12		
	D	Set User Integer Variable 13		
	E	Set User Integer Variable 14		
	F	Set User Integer Variable 15		
	10	Set User Integer Variable 16		
0x2006	01	Set Acceleration 1, ch.1	S32 WO	"AC", page 165
	02	Set Acceleration 1, ch.2		
0x2007	01	Set Deceleration 1, ch.1	S32 WO	"DC", page 167
	02	Set Deceleration 1, ch.2		
0x2008	00	Set All Digital Out bits	U8 WO	"DS", page 167
0x2009	00	Set Individual Digital Out bits	U8 WO	"D1", page 167
0x200A	00	Reset Individual Digital Out bits	U8 WO	"D0", page 167

TABLE 16. Object Dictionary

Index	Sub	Entry Name	Data Type & Access	Command Reference & Page
0x200B	01	Load Home Counter, ch.1	U8 WO	"H", page 169
	02	Load Home Counter, ch.2		
0x200C	00	Emergency Shutdown	U8 WO	"EX", page 168
0x200D	00	Release Shutdown	U8 WO	"MG", page 169
0x200E	00	Stop in all modes	U8 WO	"MS", page 169
0x200F	01	Set Pos Relative, ch.1	S32 WO	"PR", page 170
	02	Set Pos Relative, ch.2		
0x2010	01	Set Next Pos Absolute, ch.1	S32 WO	"PX", page 170
	02	Set Next Pos Absolute, ch.2		
0x2011	01	Set Next Pos Relative, ch.1	S32 WO	"PRX", page 170
	02	Set Next Pos Relative, ch.2		
0x2012	01	Set Next Acceleration, ch.1	S32 WO	"AX", page 165
	02	Set Next Acceleration, ch.2		
0x2013	01	Set Next Deceleration, ch.1	S32 WO	"DX", page 168
	02	Set Next Deceleration, ch.2		
0x2014	01	Set Next Velocity, ch.1	S32 WO	"SX", page 171
	02	Set Next Velocity, ch.2		
0x2015	01	Set User Bool Variable 1	S32 WO	"B", page 165
	02	Set User Bool Variable 2		
	...			
	07	Set User Bool Variable 7		
	08	Set User Bool Variable 8	S32 WO	
	09	Set User Bool Variable 9		
	0A	Set User Bool Variable 10		
	...			
	0F	Set User Bool Variable 15		
	10	Set User Bool Variable 16	S32 WO	
	11	Set User Bool Variable 17		
	12	Set User Bool Variable 18		
	13	Set User Bool Variable 19		
	14	Set User Bool Variable 20		
	15	Set User Bool Variable 21		
	...			
1F	Set User Bool Variable 31			
20	Set User Bool Variable 32			
0x2017	00	Save Config to Flash	U8 WO	"EES", page 168

TABLE 16. Object Dictionary

Index	Sub	Entry Name	Data Type & Access	Command Reference & Page
Runtime Queries				
0x2100	01	Read Motor Amps, ch.1	S16 RO	"A", page 173
	02	Read Motor Amps, ch.2	S16 RO	
0x2101	01	Read Actual Motor Command, ch.1	S16 RO	"M", page 182
	02	Read Actual Motor Command, ch.2		
0x2102	01	Read Applied Power Level, ch.1	S16 RO	"P", page 184
	02	Read Applied Power Level, ch.2	S16 RO	
0x2103	01	Read Encoder Motor Speed, ch.1	S16 RO	"S", page 185
	02	Read Encoder Motor Speed, ch.2	S16 RO	
0x2104	01	Read Absolute Encoder Count, ch.1	S32 RO	"C", page 176
	02	Read Absolute Encoder Count, ch.2		
0x2105	01	Read Absolute Brushless Counter, ch.1	S32 RO	"CB", page 176
	02	Read Absolute Brushless Counter, ch.2		
0x2106	01	Read User Integer Variable 1	S32 RO	"VAR", page 187
	02	Read User Integer Variable 2	S32 RO	
	03	Read User Integer Variable 3		
	04	Read User Integer Variable 4	S32 RO	
	05	Read User Integer Variable 5		
	06	Read User Integer Variable 6	S32 RO	
	07	Read User Integer Variable 7		
	08	Read User Integer Variable 8	S32 RO	
	09	Read User Integer Variable 9		
	0A	Read User Integer Variable 10	S32 RO	
	...			
	0E	Read User Integer Variable 14	S32 RO	
	0F	Read User Integer Variable 15		
0x2107	01	Read Encoder Motor Speed as 1/1000 of Max, ch.1	S16 RO	"SR", page 185
	02	Read Encoder Motor Speed as 1/1000 of Max, ch.2		
0x2108	01	Read Encoder Count Relative, ch.1	S32 RO	"CR", page 178
	02	Read Encoder Count Relative, ch.2		
0x2109	01	Read Brushless Count Relative, ch.1	S32 RO	"CBR", page 177
	02	Read Brushless Count Relative, ch.2		

TABLE 16. Object Dictionary

Index	Sub	Entry Name	Data Type & Access	Command Reference & Page
0x210A	01	Read BL Motor Speed in RPM, ch.1	S16 RO	"BS", page 175
	02	Read BL Motor Speed in RPM, ch.2		
0x210B	01	Read BL Motor Speed as 1/1000 of Max, ch.1	S16 RO	"BSR", page 175
	02	Read BL Motor Speed as 1/1000 of Max, ch.2		
0x210C	01	Read Battery Amps, ch.1	S16 RO	"BA", page 175
	02	Read Battery Amps, ch.2		
0x210D	01	Read Internal Voltages (V Int)	U16 RO	"V", page 186
	02	Read Internal Voltages (V Bat)	U16 RO	
	03	Read Internal Voltages (V 5Vout)	U16 RO	
0x210E	00	Read All Digital Inputs	U32 RO	"D", page 178
0x210F	01	Read Case & Internal Temperatures (MCU Temperature)	S8 RO	"T", page 185
	02	Read Case & Internal Temperatures (ch.1)		
	03	Read Case & Internal Temperatures (ch.2)	S8 RO	
0x2110	01	Read Feedback, ch.1	S16 RO	"F", page 180
	02	Read Feedback, ch.2	S16 RO	
0x2111	00	Read Status Flags	U8 RO	"FS", page 181
0x2112	00	Read Fault Flags	U8 RO	"FF", page 180
0x2113	00	Read Current Digital Outputs	U8 RO	"DO", page 179
0x2114	01	Read Closed Loop Error, ch.1	S32 RO	"E", page 179
	02	Read Closed Loop Error, ch.2		
0x2115	01	Read User Bool Variable 1	S32 RO	"B", page 174
	02	Read User Bool Variable 2		
	03	Read User Bool Variable 3		
	04	Read User Bool Variable 4		
	05	Read User Bool Variable 5		
	06	Read User Bool Variable 6		
	07	Read User Bool Variable 7		
	08	Read User Bool Variable 8		
	09	Read User Bool Variable 9		
	...			
	1E	Read User Bool Variable 30		
	1F	Read User Bool Variable 31		
20	Read User Bool Variable 32			
0x2116	01	Read Internal Serial Command, ch.1	S32 RO	"CIS", page 178
	02	Read Internal Serial Command, ch.2		

TABLE 16. Object Dictionary

Index	Sub	Entry Name	Data Type & Access	Command Reference & Page
0x2117	01	Read Internal Analog Command, ch.1	S32 RO	"CIA", page 177
	02	Read Internal Analog Command, ch.2		
0x2118	01	Read Internal Pulse Command, ch.1	S32 RO	"CIP", page 177
	02	Read Internal Pulse Command, ch.2		
0x2119	00	Read Time	U32 RO	"TM", page 185
0x211A	01	Read Spektrum Radio Capture 1	U16 RO	"K", page 181
	02	Read Spektrum Radio Capture 2		
	03	Read Spektrum Radio Capture 3		
	04	Read Spektrum Radio Capture 4		
	05	Read Spektrum Radio Capture 5		
	06	Read Spektrum Radio Capture 6		
	07	Read Spektrum Radio Capture 7		
0x211B	01	Destination Pos Reached flag, ch.1	U8 RO	"DR", page 179
	02	Destination Pos Reached flag, ch.2		
0x211C	01	Read MEMS Accelerometer, X axis	S32 RO	"MA", page 182
	02	Read MEMS Accelerometer, Y axis		
	03	Read MEMS Accelerometer, Z axis		
0x211D	00	Read Magsensor Track Detect	U16 RW	"MGD", page 183
0x211E	00	Read Magsensor Track Position,	U8 RW	"MGT", page 183
0x211F	01	Read Magsensor Markers	U8RW	"MGM", page 183
0x2120	00	Read Magsensor Status	U8 RW	"MGS", page 183
0x2121	00	Read Motor Status Flags	U8 RO	"FM", page 180
0x6400	01	Read Individual Digital Input 1	S32 RO	"DI", page 178
	02	Read Individual Digital Input 2		
	03	Read Individual Digital Input 3		
	04	Read Individual Digital Input 4		
	...	Repeat for all inputs		
0x6401	01	Read Analog Input 1	S16 RO	"AI", page 174
	02	Read Analog Input 2		
	03	Read Analog Input 3		
	04	Read Analog Input 4		
	...	Repeat for all inputs		
0x6402	01	Read Analog Input 1 Converted	S16 RO	"AIC", page 174
	02	Read Analog Input 2 Converted		
	03	Read Analog Input 3 Converted		
	04	Read Analog Input 4 Converted		
	...	Repeat for all inputs		

TABLE 16. Object Dictionary

Index	Sub	Entry Name	Data Type & Access	Command Reference & Page
0x6403	01	Read Pulse Input 1	S16 RO	"PI", page 184
	02	Read Pulse Input 2		
	03	Read Pulse Input 3		
	04	Read Pulse Input 4		
	...	Repeat for all inputs		
0x6404	01	Read Pulse Input 1 Converted	S16 RO	"PIC", page 184
	02	Read Pulse Input 2 Converted		
	03	Read Pulse Input 3 Converted		
	04	Read Pulse Input 4 Converted		
	...	Repeat for all inputs		

SECTION 15

MicroBasic Scripting

One of the controller's most powerful and innovative features is the ability for the user to write programs that are permanently saved into, and run from the controller's Flash Memory. This capability is the equivalent of combining the motor controller functionality and this of a PLC or Single Board Computer directly into the controller. Script can be simple or elaborate, and can be used for various purposes:

- **Complex sequences:**
MicroBasic Scripts can be written to chain motion sequences based on the status of analog/digital inputs, motor position, or other measured parameters. For example, motors can be made to move to different count values based on the status of pushbuttons and the reaching of switches on the path.
- **Adapt parameters at runtime**
MicroBasic Scripts can read and write most of the controller's configuration settings at runtime. For example, the Amps limit can be made to change during operation based on the measured heatsink temperature.
- **Create new functions**
Scripting can be used for adding functions or operating modes that may be needed for a given application. For example, a script can compute the motor power by multiplying the measured Amps by the measured battery Voltage, and regularly send the result via the serial port for Telemetry purposes.
- **Autonomous operation**
MicroBasic Scripts can be written to perform fully autonomous operations. For example the complete functionality of a line following robot can easily be written and fitted into the controller.

Script Structure and Possibilities

Scripts are written in a Basic-Like computer language. Because of its literal syntax that is very close to the every-day written English, this language is very easy to learn and simple scripts can be written in minutes. The MicroBasic scripting language also includes support for structured programming, allowing fairly sophisticated programs to be written. Several shortcuts borrowed from the C-language (`++`, `+=`, ...) are also included in the scripting language and may be optionally used to write shorter programs.

The complete details on the language can be found in the MicroBasic Language Reference on page 143.

Source Program and Bytecodes

Programs written in this Basic-like language are interpreted into an intermediate string of Bytecode instructions that are then downloaded and executed in the controller. This two-step structure ensures that only useful information is stored in the controller and results in significantly higher performance execution over systems that interpret Basic code directly. This structure is for the most part entirely invisible to the programmer as the source editing is the only thing that is visible on the PC, and the translation and done in the background just prior to downloading to the controller.

The controller can store 8192 Bytecodes. This translates to approximately 1500 lines of MicroBasic source.

Variables Types and Storage

Scripts can store signed 32-bit integer variables and Boolean variable. Integer variables can handle values up to +/- 2,147,483,647. Boolean variables only contain a True or False state. The language also supports single dimensional arrays of integers and Boolean variables.

In total, up to 1024 Integer variables and up to 1024 Boolean variables can be stored in the controller. An array of n variables will take the storage space of n variables.

The language only works with Integer or Boolean values. It is not possible to store or manipulate decimal values. This constraint results in more efficient memory usage and faster script execution. This constraint is usually not a limitation as it is generally sufficient to work with smaller units (e.g. millivolts instead of Volts, or milliamps instead of Amps) to achieve the same precision as when working with decimals.

The language does not support String variables and does not have string manipulation functions. Basic string support is provided for the Print command.

Variable content after Reset

All integer variables are reset to 0 and all Boolean variables are reset to False after the controller is powered up or reset. When using a variable for the first time in a script, its value can be considered as 0 without the need to initialize it. Integer and Boolean variables are also reset whenever a new script is loaded.

When pausing and resuming a script, all variables keep the values they had at the time the script was paused.

Controller Hardware Read and Write Functions

The MicroBasic scripting language includes special functions for reading and writing configuration parameters. Most configuration parameters that can be read and changed using the Configuration Tab in the Roborun PC utility or using the Configuration serial commands, can be read and changed from within a script. The GetConfig and SetConfig functions are used for this purpose.

The GetValue function is available for reading real-time operating parameters such as Analog/Digital input status, Amps, Speed or Temperature.

The SetCommand function is used to send motor commands or to activate the Digital Outputs. Practically all controller parameters can be access using these 4 commands, typically by adding the command name as defined in the Serial (RS232/USB) Operation on page 111 preceded with the "_" character. For example, reading the Amps limit configuration for channel 1 is done using `getvalue(_ALIM, 1)`.

See the MicroBasic Language Reference on page 143 for details on these functions and how to use them.

Timers and Wait

The language supports four 32-bit Timer registers. Timers are counters that can be loaded with a value using a script command. The timers are then counting down every millisecond independently of the script execution status. Functions are included in the language to load a timer, read its current count value, pause/resume count, and check if it has reached 0. Timers are very useful for implementing time-based motion sequences.

A wait function is implemented for suspending script execution for a set amount of time. When such an instruction is encountered, script execution immediately stops and no more time is allocated to script execution until the specified amounts of milliseconds have elapsed. Script execution resumes at the instruction that follows the wait.

Execution Time Slot and Execution Speed

MicroBasic scripts are executed in the free time that is available every 1ms, after the controller has completed all its motion control processing. The available time can therefore vary depending on the functions that are enabled or disabled in the controller configuration. For example more time is available for scripting if the controller is handling a single motor in open loop than if two motors are operated in closed loop with encoders. At the end of the allocated time, the script execution is suspended, motor control functions are performed, and scripts resumed. An execution speed averaging 50,000 lines of MicroBasic code, or higher, per second can be expected in most cases.

Protections

No protection against user error is performed at execution time. For example, writing or reading in an array variable with an index value that is beyond the 1024 variables available in the controller may cause malfunction or system crash. Nesting more than 64 levels of subroutines (i.e. subroutines called from subroutines, ...) will also cause potential problems. It is up to the programmer to carefully check the script's behavior in all conditions.

Print Command Restrictions

A print function is available in the language for outputting script results onto the serial or USB port. Since script execution is very fast, it is easy to send more data to the serial or USB port than can actually be output physically by these ports. The print command is therefore limited to 32 characters per 1ms time slot. Printing longer strings will force a 1ms pause to be inserted in the program execution every 32 characters.

Editing, Building, Simulating and Executing Scripts

Editing Scripts

An editor is available for scripting in the RoborunPlus PC utility. See Scripting Tab on page 243 (Roborun scripting) for details on how to launch and operate the editor.

The edit window resembles this of a typical IDE editor with, most noticeably, changes in the fonts and colors depending on the type of entry that is recognized as it is entered. This capability makes code easier to read and provides a first level of error checking.

Code is entered as free-form text with no restriction in term of length, indents use, or other.

Building Scripts

Building is the process of converting the Basic source code in the intermediate Bytecode language that is understood by the controller. This step is nearly instantaneous and normally transparent to the user, unless errors are detected in the program.

Build is called automatically when clicking on the “Download to Device” or “Simulate” buttons.

Building can be called independently by clicking on the “Build” button. This step is normally not necessary but it can be useful in order to compare the memory usage efficiency of one script compared to another.

Simulating Scripts

Scripts can be ran directly on the PC in simulation mode. Clicking on the Simulate button will cause the script to be built and launch a simulator in which the code is executed. This feature is useful for writing, testing and debugging scripts. The simulator works exactly the same way as the controller with the following exceptions.

- Execution speed is different.
- Controller configurations and operating parameters are not accessible from the simulator
- Controller commands cannot be sent from the simulator
- The four Timers operate differently in the simulator

In the simulator, any attempt to read a Controller configuration (example Amps limit) or a Controller Runtime parameter (e.g. Volts, Temperature) will cause a prompt to be displayed for the user to enter a value. Entering no value and hitting Enter, will cause the same value that was entered last for the same parameter to be used. If this is the first time the user is prompted for a given parameter, 0 will be entered if hitting Enter with no data.

When a function in the simulator attempts to write a configuration or a command, then the console displays the parameter name and parameter value in the console.

Script execution in the simulator starts immediately after clicking on the Simulate button and the console window opens.

Simulated scripts are stopped when closing the simulator console.

Downloading MicroBasic Scripts to the controller

The Download to Device button will cause the MicroBasic script to be built and then transferred into the controller's flash memory where it will remain permanently unless overwritten by a new script.

The download process requires no other particular attention. There is no warning that a script may already be present in Flash. A progress bar will appear for the duration of the transfer which can be from a fraction of a second to a few seconds. When the download is completed successfully, no message is displayed, and control is returned to the editor.

An error message will appear only if the controller is not ready to receive or if an error occurred during the download phase.

Downloading a new script while a script is already running will cause the running script to stop execution. All variables will also be cleared when a new script is downloaded.

Executing MicroBasic Scripts

Once stored in the Controller's Flash memory, scripts can be executed either "Manually" or automatically every time the controller is started.

Manual launch is done by sending commands via the Serial or USB port. When connected to the PC running the PC utility, the launch command can be entered from the Console tab. The commands for running as stopping scripts are:

- **!r** : Start or Resume Script
- **!r 0**: Pause Script execution
- **!r 1**: Resume Script from pause point. All integer and Boolean variables have values they had at the time the script was paused.
- **!r 2**: Restarts Script from start. Set all integer variables to 0, sets all Boolean variables to False. Clears and stops the 4 timers.

If the controller is connected to a microcomputer, it is best to have the microcomputer start script execution by sending the !r command via the serial port or USB.

Scripts can be launched automatically after controller power up or after reset by setting the Auto Script configuration to Enable in the controller configuration memory. When enabled, if a script is detected in Flash memory after reset, script execution will be enabled and the script will run as when the !r command is manually entered. Once running, scripts can be paused and resumed using the commands above.

Important Warning

Prior to set a script to run automatically at start-up, make sure that your script will not include errors that can make the controller processor crash. Once set to automatically start, a script will always start running shortly after power up. If a script contains code that causes system crash, the controller will never reach a state where it will be possible to communicate with it to stop the script and/or load a new one. If this ever happens, the only possible recovery is to connect the controller to a PC via the serial port and run a terminal emulation software. Immediately after receiving the Firmware ID, type and send !r 0 to stop the script before it is actually launched. Alternatively, you may reload the controller's firmware.

Script Command Priorities

When sending a Motor or Digital Output command from the script, it will be interpreted by the controller the same way as a serial command (RS232 or USB). This means that the RS232 watchdog timer will trigger in if no commands are sent from the script within the watchdog timeout. If a serial command is received from the serial/USB port at the same time a command is sent from the script, both will be accepted and this can cause conflicts if they are both relating to the same channel. Care must be taken to keep to avoid, for example, cases where the script commands one motor to go to a set level while a serial command is received to set the motor to a different level. To avoid this problem when using the Roborun PC utility, click on the mute button to stop commands sending from the PC.

Script commands also share the same priority level as Serial commands. Use the Command Priority Setting (See "Command Priorities" on page 114) to set the priority of commands issued from the script vs. commands received from the Pulse Inputs or Analog Inputs.

MicroBasic Scripting Techniques

Writing scripts for the Roboteq controllers is similar to writing programs for any other computer. Scripts can be called to run once and terminate when done. Alternatively, scripts can be written so that they run continuously.

Single Execution Scripts

These scripts are programs that perform a number of functions and eventually terminate. These kind of scripts can be summarized in the flow chart below. The amount of processing can be simple or very complex but the script has a clear begin and end.

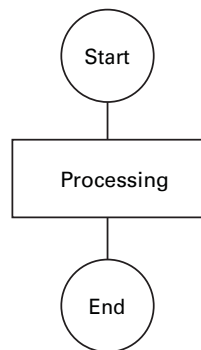

FIGURE 64. Single execution scripts

Continuous Scripts

More often, scripts will be active permanently, reacting differently based on the status of analog/ digital inputs, or operating parameters (Amps, Volts, Temperature, Speed, Count, ...), and continuously updating the motor power and/or digital outputs. These scripts have

a beginning but no end as they continuously loop back to the top. A typical loop construction is shown in the flow chart below.

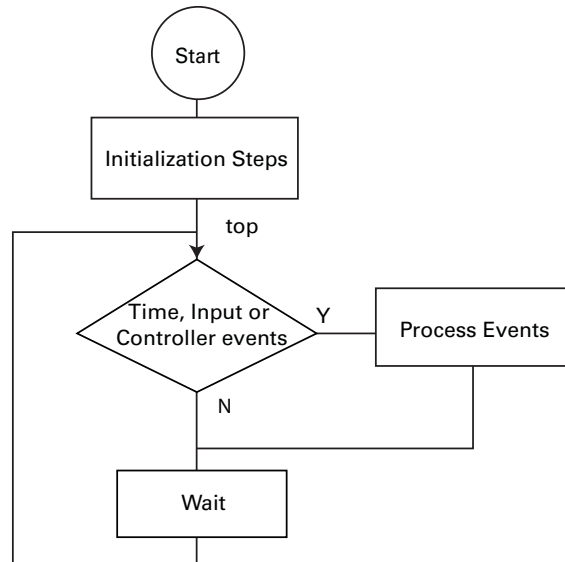

FIGURE 65. Continuous execution scripts

Often, some actions must be done only once when script starts running. This could be setting the controller in an initial configuration or computing constants that will then be used in the script's main execution loop.

The main element of a continuous script is the scanning of the input ports, timers, or controller operating parameters. If specific events are detected, then the script jumps to steps related to these events. Otherwise, no action is taken.

Prior to looping back to the top of the loop, it is highly recommended to insert a wait time. The wait period should be only as short as it needs to be in order to avoid using processing resources unnecessarily. For example, a script that monitors the battery and triggers an output when the battery is low does not need to run every millisecond. A wait time of 100ms would be adequate and keep the controller from allocating unnecessary time to script execution.

Optimizing Scripts for Integer Math

Scripts only use integer values as variables and for all internal calculation. This leads to very fast execution and lower computing resource usage. However, it does also cause limitation. These can easily be overcome with the following techniques.

First, if precision is needed, work with smaller units. In this simple Ohm-law example, whereas 10V divided by 3A results in 3 Ohm, the same calculation using different units will give a higher precision result: 10000mV divided by 3A results in 3333 mOhm

Second, the order in which terms are evaluated in an expression can make a very big difference. For example $(10 / 20) * 1000$ will produce a result of 0 while $(10 * 1000) / 20$ produces 5000. The two expressions are mathematically equivalent but not if numbers can only be integers.

Script Examples

Several sample scripts are included in the RoborunPlus installation.

Below is a continuous script that checks the heat sink temperature at both sides of the controller enclosure and lowers the amps limit to 50A when the average temperature exceeds 50oC. Amps limit is set at 100A when temperature is below 50o. Notice that as temperature is changing slowly, the loop update rate has been set at a relatively slow 100ms rate.

```
' This script regularly reads the current temperature at both sides
' of the heat sink and changes the Amps limit for both motors to 50A
' when the average temperature is above 50oC. Amps limit is set to
' 100A when temperature is below or equal to 50oC.
' Since temperature changes slowly, the script is repeated every 100ms

' This script is distributed "AS IS"; there is no maintenance
' and no warranty is made pertaining to its performance or applicability

top: ' Label marking the beginning of the script.

' Read the actual command value
Temperature1 = getvalue(_TEMP,1)
Temperature2 = getvalue(_TEMP,1)
TempAvg = (Temperature1 + Temperature2) / 2

' If command value is higher than 500 then configure
' acceleration and deceleration values for channel 1 to 200

if TempAvg > 50 then
    setconfig(_ALIM, 1, 500)
    setconfig(_ALIM, 2, 500)
else
' If command value is lower than or equal to 500 then configure
' acceleration and deceleration values for channel 1 to 5000
    setconfig(_ALIM, 1, 1000)
    setconfig(_ALIM, 2, 1000)
end if

' Pause the script for 50ms
wait(100)
' Repeat the script from the start
goto top
```

Strings

Strings are any string of printable characters enclosed in a pair of quotation marks. Non printing characters may be represented by simple or hexadecimal escape sequence. Micro Basic only handles strings using the Print command. Strings cannot be stored in variable and no string handling instructions exist.

- **Simple Escape Sequence**

The following escape sequences can be used to print non-visible or characters:

Sequence	Description
\'	Single quote
\"	Double quote
\\	Backslash
\0	Null
\a	Alert
\b	Backspace
\f	Form feed
\n	New line
\r	Carriage return
\t	Horizontal tab
\v	Vertical tab

- **Hexadecimal Escape Sequence**

Hexadecimal escape sequence is represented in a set of hexadecimal digits (0-9, A-F) preceded by \x in the string (such as \x10 for character with ASCII 16).

Since a hexadecimal escape sequence can have a variable number of hex digits, the string literal "\x123" contains a single character with hex value 123. To create a string containing the character with hex value 12 followed by the character 3, one could write "\x00123".

So, to represent a string with the statement "Hello World!" followed by a new line, you may use the following syntax:

```
"Hello World!\n"
```

Blocks and Labels

A group of executable statements is called a statement block. Execution of a statement block begins with the first statement in the block. Once a statement has been executed, the next statement in lexical order is executed, unless a statement transfers execution elsewhere.

A label is an identifier that identifies a particular position within the statement block that can be used as the target of a branch statement such as `GoTo`, `GoSub` or `Return`.

Label declaration statements must appear at the beginning of a line. Label declaration statements must always be followed by a colon (:) as the following:

```
Print_Label:
  Print("Hello World!")
```

Label name should start with alphabetical character and followed by zero or more alphanumeric characters or underscore. Label names cannot start with underscore. Labels names cannot match any of Micro Basic reserved words.

Label names are case insensitive that is `PrintLabel` is identical to `printlabel`.

The scope of a label extends whole the program. Labels cannot be declared more than once in the program.

Variables

Micro Basic contains only two types of variable (`Integer` and `Boolean`) in addition to arrays of these types. `Boolean` and arrays must be declared before use, but `Integer` variables may not be declared unless you use the `Option Explicit` compiler directive.

```
Option Explicit
```

Variables can be declared using DIM keyword (see `Dim (Variable Declaration)` on page 147).

Variable name should start with alphabetical character and followed by zero or more alphanumeric characters or underscore. Variable names cannot start with underscore. Variable names cannot match any of Micro Basic reserved words.

Variable names are case insensitive, that is `VAR` is identical to `var`.

The scope of a variable extends whole the program. Variables cannot be declared more than once in the program.

Arrays

Arrays is special variables that holds a set of values of the variable type. Arrays are declared using DIM command (see `Dim (Variable Declaration)` on page 147).

To access specific element in the array you can use the indexer [] (square brackets). Arrays indices are zero based, so index of 5 refer to the 6th element of the array.

```
arr[0] = 10'Set the value of the first element in the array to 10.
```

```
a = arr[5]'Store the 6th element of the array into variable a.
```

Terminology

In the following sections we will introduce Micro Basic commands and how it is used, and here is the list of terminology used in the following sections:

- Micro Basic commands and functions will be marked in blue and cyan respectively.
- Anything enclosed in < > is mandatory and must be supplied.

- Anything enclosed in [] is optional, except for arrays where the square brackets is used as indexers.
- Anything enclosed in { } and separated by | characters are multi choice options.
- Any items followed by an ellipsis, ... , may be repeated any number of times.
- Any punctuation and symbols, except those above, are part of the structure and must be included.

var	is any valid variable name including arrays.
arr	is any valid array name.
expression	is any expression returning a result.
condition	is any expression returning a boolean result.
stmt	is single Micro Basic statement.
block	is zero or more Micro Basic statements.
label	is any valid label name.
n	is a positive integer value.
str	is a valid string literal.

Keywords

A keyword is a word that has special meaning in a language construct. All keywords are reserved by the language and may not be used as variables or label names. Below is a list of all Micro Basic keywords:

And	AndWhile	As	Boolean	Continue
Dim	Do	Else	Elseif	End
Evaluate	Exit	Explicit	False	For
GoSub	GoTo	If	Integer	Loop
Mod	Next	Not	Option	Or
Print	Return	Step	Terminate	Then
To	ToBool	True	Until	While
XOr				

Operators

Micro Basic provides a large set of operators, which are symbols or keywords that specify which operations to perform in an expression. Micro Basic predefines the usual arithmetic and logical operators, as well as a variety of others as shown in the following table.

Category	Operators					
Arithmetic	+	-	*	/	Mod	
Logical (boolean and bitwise)	And	Or	XOr	Not	True	False
Increment, decrement	++	--				
Shift	<<	>>				
Relational	=	<>	<	>	<=	>=

Category	Operators						
Assignment	=	+=	--	*=	/=	<<=	>>=
Indexing	[]						

Micro Basic Functions

Micro Basic currently support only one function called Abs (see Abs Function on page 153).

Controller Configuration and Commands

The following is a set of device functions for interacting with the Controller:

SetConfig	Set a configuration parameter
SetCommand	Send a Real Time command
GetConfig	Read a configuration parameter
GetValue	Read an operating value

Timers Commands

The following is a set of functions for interacting with the timers:

SetTimerCount	Set number of milliseconds for timer to count.
SetTimerState	Set state of a specific timer.
GetTimerCount	Read timer count.
GetTimerState	Read state of a specific timer.

Option (Compilation Options)

Micro Basic by default treats undeclared identifiers as integer variables. If you want the compilers checks that every variable used in the program is declared and generate compilation error if a variable is not previously declared, you may use `Option explicit` compiler option by placing the following at the beginning of the program:

```
Option Explicit
```

Dim (Variable Declaration)

Micro Basic contains only two types of variable (`Integer` and `Boolean`) in addition to arrays of these types. `Boolean` and arrays must be declared before use, but `Integer` variables may not be declared unless you use the `Option Explicit` compiler directive.

```
Dim var As { Integer | Boolean }
```

The following example illustrates how to declare `Integer` variable:

```
Dim intVar As Integer
```

Arrays declaration uses a different syntax, where you should specify the array length between square brackets []. Array length should be integer value greater than 1.

```
Dim arr[n] As { Integer | Boolean }
```

The following example illustrates how to declare array of 10 integers:

```
Dim arr[10] As Integer
```

To access array elements (get/set), you may need to take a look to Arrays section (see Arrays on page 145).

Variable and arrays names should follow specification stated in the Variables section (see Variables on page 145).

If...Then Statement

- Line If

```
If <condition> Then <stmt> [Else <stmt>]
```

- Block If

```
If <condition> [Then]
    <block>
[ElseIf <condition> [Then]
    <block>]
[ElseIf <condition> [Then]
    <block>]
...
[Else
    <block>]
End If
```

An If...Then statement is the basic conditional statement. If the expression in the If statement is true, the statements enclosed by the If block are executed. If the expression is false, each of the ElseIf expressions is evaluated. If one of the ElseIf expressions evaluates to true, the corresponding block is executed. If no expression evaluates to true and there is an Else block, the Else block is executed. Once a block finishes executing, execution passes to the end of the If...Then statement.

The line version of the If statement has a single statement to be executed if the If expression is true and an optional statement to be executed if the expression is false. For example:

```
Dim a As Integer
Dim b As Integer

a = 10
b = 20
' Block If statement.
If a < b Then
    a = b
Else
    b = a
End If
```

```
' Line If statement
If a < b Then a = b Else b = a
```

Below is an example where ElseIf takes place:

```
If score >= 90 Then
    grade = 1
ElseIf score >= 80 Then
    grade = 2
ElseIf score >= 70 Then
    grade = 3
Else
    grade = 4
End If
```

For...Next Statement

Micro Basic contains two types of For...Next loops:

- Traditional For...Next:**
 Traditional For...Next exists for backward compatibility with Basic, but it is not recommended due to its inefficient execution.

Traditional For...Next is the same syntax as Basic For...Next statement.

- C-Style For...Next:**
 This is a new style of For...Next statement optimized to work with Roboteq controllers and it is recommended to be used. It is the same semantics as C++ for loop, but with a different syntax.

```
For <var> = <expression> AndWhile <condition> [Evaluate
<stmt>]
    <block>
Next
```

The c-style for loop is executed by initialize the loop variable, then the loop continues while the condition is true and after execution of single loop the evaluate statement is executed then continues to next loop.

```
Dim arr[10] As Integer
For i = 0 AndWhile i < 10
    arr[i] = -1
Next
```

The previous example illustrates how to initialize array elements to -1.

The following example illustrates how to use Evaluate to print even values from 0-10 inclusive:

```
For i = 0 AndWhile i <= 10 Evaluate i += 2
    Print(i, "\n")
Next
```

While/Do Statements

- **While...End While Statement**

```
While <condition>
  <block>
End While
```

Example:

```
a = 10
While a > 0
  Print("a = ", a, "\n")
  a--
End While
Print("Loop ended with a = ", a, "\n")
```

- **Do While...Loop Statement**

```
Do While <condition>
  <block>
Loop
```

The Do While...Loop statement is the same as functionality of the While...End While statement but uses a different syntax.

```
a = 10
Do While a > 0
  Print("a = ", a, "\n")
  a--
Loop
Print("Loop ended with a = ", a, "\n")
```

- **Do Until...Loop Statement**

```
Do Until <condition>
  <block>
Loop
```

Unlike Do While...Loop statement, Do Until...Loop statement exist the loop when the expression evaluates to true.

```
a = 10
Do Until a = 0
  Print("a = ", a, "\n")
  a--
Loop
Print("Loop ended with a = ", a, "\n")
```

- **Do...Loop While Statement**

```
Do
  <block>
Loop While <condition>
```

Do...Loop While statement grants that the loop block will be executed at least once as the condition is evaluated and checked after executing the block.

```

a = 10
Do
    Print("a = ", a, "\n")
    a--
Loop While a > 0
Print("Loop ended with a = ", a, "\n")
    
```

- **Do...Loop Until Statement**

```

Do
    <block>
Loop Until <condition>
    
```

Unlike Do...Loop While statement, Do...Loop Until statement exist the loop when the expression evaluates to true.

```

a = 10
Do
    Print("a = ", a, "\n")
    a--
Loop Until a = 0
Print("Loop ended with a = ", a, "\n")
    
```

Terminate Statement

The Terminate statement ends the execution of the program.

```
Terminate
```

Exit Statement

The following is the syntax of Exit statement:

```
Exit { For | While | Do }
```

An **Exit** statement transfers execution to the next statement to immediately containing block statement of the specified kind. If the **Exit** statement is not contained within the kind of block specified in the statement, a compile-time error occurs.

The following is an example of how to use **Exit** statement in **While** loop:

```

While a > 0
    If b = 0 Then Exit While
End While
    
```

Continue Statement

The following is the syntax of **Continue** statement:

```
Continue { For | While | Do }
```

A **Continue** statement transfers execution to the beginning of immediately containing block statement of the specified kind. If the **Continue** statement is not contained within the kind of block specified in the statement, a compile-time error occurs.

The following is an example of how to use Continue statement in While loop:

```
While a > 0
  If b = 0 Then Continue While
End While
```

GoTo Statement

A GoTo statement causes execution to transfer to the specified label. GoTo keyword should be followed by the label name.

```
GoTo <label>
```

The following example illustrates how to use GoTo statement:

```
GoTo Target_Label
Print("This will not be printed.\n")
Target_Label:
  Print("This will be printed.\n")
```

GoSub/Return Statements

GoSub used to call a subroutine at specific label. Program execution is transferred to the specified label. Unlike the GoTo statement, GoSub remembers the calling point. Upon encountering a Return statement the execution will continue the next statement after the GoSub statement.

```
GoSub <label>
```

```
Return
```

Consider the following example:

```
Print("The first line.")
GoSub PrintLine
Print("The second line.")
GoSub PrintLine
Terminate

PrintLine:
  Print("\n")
  Return
```

The program will begin with executing the first print statement. Upon encountering the GoSub statement, the execution will be transferred to the given **PrintLine** label. The program prints the new line and upon encountering the Return statement the execution will be returning back to the second print statement and so on.

ToBool Statement

Converts the given expression into boolean value. It will be return `False` if expression evaluates to zero, `True` otherwise.

```
ToBool(<expression>)
```

Consider the following example:

```
Print(ToBool(a), "\n")
```

The previous example will output `False` if value of `a` equals to zero, `True` otherwise.

Print Statement

Output the list of expression passed.

```
Print({str | expression | ToBool(<expression>)}[, {str | expression  
| ToBool(<expression>)}]...)
```

The print statement consists of the `Print` keyword followed by a list of expressions separated by comma. You can use `ToBool` keyword to force print of expressions as `Boolean`. Strings are C++ style strings with escape characters as described in the Strings section (see Strings on page 144).

```
a = 3  
b = 5  
Print("a = ", a, ", b = ", b, "\n")  
Print("Is a less than b = ", ToBool(a < b), "\n")
```

Abs Function

Returns the absolute value of an expression.

```
Abs(<expression>)
```

Example:

```
a = 5  
b = Abs(a - 2 * 10)
```

+ Operator

The `+` operator can function as either a unary or a binary operator.

```
+ expression  
expression + expression
```

- Operator

The `-` operator can function as either a unary or a binary operator.

```
- expression  
expression - expression
```

*** Operator**

The multiplication operator (*) computes the product of its operands.

```
expression * expression
```

/ Operator

The division operator (/) divides its first operand by its second.

```
expression / expression
```

Mod Operator

The modulus operator (Mod) computes the remainder after dividing its first operand by its second.

```
expression Mod expression
```

And Operator

The (And) operator functions only as a binary operator. For numbers, it computes the bitwise AND of its operands. For boolean operands, it computes the logical AND for its operands; that is the result is true if and only if both operands are true.

```
expression And expression
```

Or Operator

The (Or) operator functions only as a binary operator. For numbers, it computes the bitwise OR of its operands. For boolean operands, it computes the logical OR for its operands; that is, the result is false if and only if both its operands are false.

```
expression Or expression
```

XOr Operator

The (XOr) operator functions only as a binary operator. For numbers, it computes the bitwise exclusive-OR of its operands. For boolean operands, it computes the logical exclusive-OR for its operands; that is, the result is true if and only if exactly one of its operands is true.

```
expression XOr expression
```

Not Operator

The (Not) operator functions only as a unary operator. For numbers, it performs a bitwise complement operation on its operand. For boolean operands, it negates its operand; that is, the result is true if and only if its operand is false.

```
Not expression
```

True Literal

The `True` keyword is a literal of type `Boolean` representing the boolean value `true`.

False Literal

The `False` keyword is a literal of type `Boolean` representing the boolean value `false`.

++ Operator

The increment operator (`++`) increments its operand by 1. The increment operator can appear before or after its operand:

```
++ var
var ++
```

The first form is a prefix increment operation. The result of the operation is the value of the operand after it has been incremented.

The second form is a postfix increment operation. The result of the operation is the value of the operand before it has been incremented.

```
a = 10
Print(a++, "\n")
Print(a, "\n")
Print(++a, "\n")
Print(a, "\n")
```

The output of previous program will be the following:

```
10
11
12
12
```

-- Operator

The decrement operator (`--`) decrements its operand by 1. The decrement operator can appear before or after its operand:

```
-- var
var --
```

The first form is a prefix decrement operation. The result of the operation is the value of the operand after it has been decremented.

The second form is a postfix decrement operation. The result of the operation is the value of the operand before it has been decremented.

```
a = 10
Print(a--, "\n")
Print(a, "\n")
Print(--a, "\n")
Print(a, "\n")
```

The output of previous program will be the following:

```
10
9
8
8
```

<< Operator

The left-shift operator (<<) shifts its first operand left by the number of bits specified by its second operand.

```
expression << expression
```

The high-order bits of left operand are discarded and the low-order empty bits are zero-filled. Shift operations never cause overflows.

>> Operator

The right-shift operator (>>) shifts its first operand right by the number of bits specified by its second operand.

```
expression >> expression
```

<> Operator

The inequality operator (<>) returns false if its operands are equal, true otherwise.

```
expression <> expression
```

< Operator

Less than relational operator (<) returns true if the first operand is less than the second, false otherwise.

```
expression < expression
```

> Operator

Greater than relational operator (>) returns true if the first operand is greater than the second, false otherwise.

```
expression > expression
```

<= Operator

Less than or equal relational operator (<=) returns true if the first operand is less than or equal to the second, false otherwise.

```
expression <= expression
```

> Operator

Greater than relational operator (>) returns true if the first operand is greater than the second, false otherwise.

```
expression > expression
```

>= Operator

Greater than or equal relational operator (>=) returns true if the first operand is greater than or equal to the second, false otherwise.

```
expression >= expression
```

+= Operator

The addition assignment operator.

```
var += expression
```

An expression using the += assignment operator, such as

```
x += y
```

is equivalent to

```
x = x + y
```

-= Operator

The subtraction assignment operator.

```
var -= expression
```

An expression using the -= assignment operator, such as

```
x -= y
```

is equivalent to

```
x = x - y
```

*= Operator

The multiplication assignment operator.

```
var *= expression
```

An expression using the *= assignment operator, such as

```
x *= y
```

is equivalent to

```
x = x * y
```

/= Operator

The division assignment operator.

```
var /= expression
```

An expression using the /= assignment operator, such as

```
x /= y
```

is equivalent to

```
x = x / y
```

<<= Operator

The left-shift assignment operator.

```
var <<= expression
```

An expression using the <<= assignment operator, such as

```
x <<= y
```

is equivalent to

```
x = x << y
```

>>= Operator

The right-shift assignment operator.

```
var >>= expression
```

An expression using the >>= assignment operator, such as

```
x >>= y
```

is equivalent to

```
x = x >> y
```

[] Operator

Square brackets ([]) are used for arrays (see Arrays on page 145).

GetValue

This function is used to read operating parameters from the controller at runtime. The function requires an Operating Item, and an optional Index as parameters. The Operating Item can be any one from the table below. The Index is used to select one of the Value Items in multi channel configurations. When accessing a unique Operating Parameter that is not part of an array, the index may be omitted, or an index value of 0 can be used.

Details on the various operating parameters that can be read can be found in the Controller's User Manual. (See "Serial (RS232/USB) Operation" on page 111)

```
GetValue(OperatingItem, [Index])
```

```
Current2 = GetValue(_BATAMPS, 2) ' Read Battery Amps for Motor 2
```

```
Sensor = GetValue(_ANAIN, 6) ' Read voltage present at Analog Input 1
```

```
Counter = GetValue(_BLCOUNTER) ' Read Brushless counter
```

TABLE 17.

Command	Short	Arguments	Description
_MOTAMPS	_A	InputNbr	Read Motor Amps
_RAWADC	_AD	InputNbr	Read Raw ADC Values
_ANAIN	_AI	InputNbr	Read Analog Inputs
_ANAINC	_AIC	InputNbr	Read Analog Inputs Converted
_BOOL	_B	VarNbr	Read User Boolean Variable
_BATAMPS	_BA	InputNbr	Read Battery Amps
_BLSPEED	_BS	none	Read BL Motor Speed in RPM
_BLRSPEED	_BSR	none	Read BL Motor Speed as 1/1000 of Max
_ABCNTR	_C	Channel	Read Absolute Encoder Count
_CAN	_CAN	Channel	Read Raw CAN Message
_BLCNTR	_CB	none	Read Absolute Brushless Counter
_BLRCNTR	_CBR	none	Read Brushless Count Relative
_CF	_CF	Channel	Read Raw CAN Received Frames Count
_CMDANA	_CIA	Channel	Read Internal Analog Command
_CMDPLS	_CIP	Channel	Read Internal Pulse Command
_CMDSER	_CIS	Channel	Read Internal Serial Command
_RELCNTR	_CR	Channel	Read Encoder Count Relative
_DIGIN	_D	InputNbr	Read All Digital Inputs
_DIN	_DI	InputNbr	Read Individual Digital Inputs
_DIGOUT	_DO	none	Read Current Digital Outputs
_DREACHED	_DR	Channel	Destination Position Reached flag
_LPERR	_E	none	Read Closed Loop Error
_FEEDBK	_F	none	Read Feedback
_FLTFLAG	_FF	none	Read Fault Flags
_FID	_FID	none	Read Firmware ID String
_STFLAG	_FS	none	Read Status Flags
_SPEKTRUM	_K	Channel	Read Spektrum Radio Capture
_LOCKED	_LK	none	Read Lock status
_MOTCMD	_M	Channel	Read Actual Motor Command
_MEMS	_MA	InputNbr	Read MEMS Accelerometer
_MBB	_MBB	VarNbr	Read Microbasic Integer Variable

TABLE 17.

Command	Short	Arguments	Description
_MBV	_MBV	VarNbr	Read Microbasic Boolean Variable
_MGDET	_MGD	none	Read Magsensor Track Detect
_MGMRKR	_MGM	Channel	Read Magsensor Markers
_MGSTATUS	_MGS	none	Read Magsensor Status
_MGTRACK	_MGT	Channel	Read Magsensor Track Position
_MOTPWR	_P	Channel	Read Applied Power Level
_PLSIN	_PI	InputNbr	Read Pulse Inputs
_PLSINC	_PIC	InputNbr	Read Pulse Inputs Converted
_ABSPEED	_S	Channel	Read Encoder Motor Speed in RPM
_RELSPEED	_SR	Channel	Read Encoder Motor Speed as 1/1000 of Max
_TEMP	_T	SensorNumber	Read Case & Internal Temperatures
_TIME	_TM	Channel	Read Time
_TRACK	_TR	Channel	Read Position Relative Tracking
_TRN	_TRN	none	Read Power Unit Tree filename
_VOLTS	_V	SensorNumber	Read Internal Voltages
_VAR	_VAR	VarNbr	Read User Integer Variable

SetCommand

This function is used to send operating commands to the controller at runtime. The function requires a Command Item, an optional Index and a Value as parameters. The Command Item can be any one from the table below. Details on the various commands, their effects and acceptable ranges can be found in the Controller's User Manual (See "Serial (RS232/USB) Operation" on page 111).

```
SetCommand(CommandItem, Value)
```

```
SetCommand(_GO, 1, 500) ' Set Motor 1 command level at 500
```

```
SetCommand(_DSET, 2) ' Activate Digital Output 2
```

TABLE 18.

Command	Short	Arguments	Description
_ACCEL	_AC	Channel Acceleration	Set Acceleration
_NXTACC	_AX	Channel Acceleration	Next Acceleration
_BOOL	_B	Variable Number Value	Set User Boolean Variable
_BIND	_BND	none	Spektrum Radio Bind
_SENCNTR	_C	Channel Counter	Set Encoder Counters
_SBLCNTR	_CB	Counter	Set Brushless Counter
_CANGO	_CG	Channel Command	Send Raw CAN frame
_CANSEND	_CS	Variable Number Value	CAN Send

TABLE 18.

Command	Short	Arguments	Description
_DRES	_D0	BitNumber	Reset Individual Digital Out bits
_DSET	_D1	BitNumber	Set Individual Digital Out bits
_DECEL	_DC	Channel Deceleration	Set Deceleration
_DOUT	_DS	Value	Set all Digital Out bits
_NXTDEC	_DX	Channel Deceleration	Next Deceleration
_EESAV	_EES	none	Save Configuration in EEPROM
_ESTOP	_EX	none	Emergency Shutdown
_GO	_G	Channel Command	Set Motor Command
_HOME	_H	Channel	Load Home counter
_MGO	_MG	none	Release Shutdown
_MSTOP	_MS	Channel	Stop in all modes
_MOTPOS	_P	Channel Position Abs	Set Position
_MPOSREL	_PR	Channel Position Rel	Go to Relative Desired Position
_NXTPOSR	_PRX	Channel Position Rel	Next Go to Relative Desired Position
_NXTPOS	_PX	Channel Next Position Abs	Next Go to Absolute Desired Position
_BRUN	_R	Mode	MicroBasic Run
_RCOUT	_RC	Channel RC Pulse	Set RC Pulse Out
_MOTVEL	_S	Channel Velocity	Set Velocity
_NXTVEL	_SX	Channel Velocity	Next Velocity
_VAR	_VAR	Variable Number Value	Set User Variable

SetConfig / GetConfig

These two functions are used to read or/and change one of the controller's configuration parameters at runtime. The changes are made in the controller's RAM and take effect immediately. Configuration changes are not stored in EEPROM.

`SetConfig` Set a configuration parameter

`GetConfig` Read a configuration parameter

Both commands require a Configuration Item, and an optional Index as parameters. The Configuration Item can be one of the valid controller configuration commands listed in the Command Reference Section. Refer to Set/Read Configuration Commands on page 194 for syntax. Simply add the underscore character "_" to read or write this configuration from within a script. The Index is used to select one of the Configuration Item in multi channel configurations. When accessing a configuration parameter that is not part of an array, index can be omitted or an index value of 0 can be used. Details on the various configurations items, their effects and acceptable values can be found in the Controller's User Manual.

Note that most but not all configuration parameters are accessible via the SetConfig or GetConfig function. No check is performed that the value you store is valid so this function must be handled with care.

When setting a configuration parameter, the new value of the parameter must be given in addition to the Configuration Item and Index.

```
GetConfig(ConfigurationItem, [Index], value)  
SetConfig(ConfigurationItem, [Index])
```

```
Accel2 = GetConfig(_MAC, 2) ' Read Acceleration parameter for Motor 2  
PWMFreq = GetConfig(_PWWF) ' Read Controller's PWM frequency  
SetConfig(_MAC, 2, Accel2 * 2) ' Make Motor2 acceleration twice as  
slow
```

SetTimerCount/GetTimerCount

These two functions used to set/get timer count.

```
SetTimerCount(<index>, <milliseconds>)  
GetTimerCount(<index>)
```

Where, index is the timer index (1-4) and milliseconds is the number of milliseconds to count.

SetTimerState/GetTimerState

These two functions used to set/get timer state (started or stopped).

```
SetTimerState(<index>, <state>)  
GetTimerState(<index>)
```

Where, index is the timer index (1-4) and state is the timer state (1 means timer reached 0 and/or stopped, 0 means timer is running).

SECTION 16

Commands Reference

This section lists all the commands accepted by the controller. Commands are typically sent via the serial (RS232 or USB) ports (See “Serial (RS232/USB) Operation” on page 111). Except for a few maintenance commands, they can also be issued from within a user script written using the MicroBasic language (See “MicroBasic Scripting” on page 135).

Most of these commands are mapped inside a CANopen Object Directory, allowing the controller to be remotely operated on a CANopen standard network (See “CANopen Interface” on page 123).

Commands Types

The controller will accept and recognize four types of commands:

Runtime commands

These start with “!” when called via the serial communication (RS232 or USB), or using the setcommand() MicroBasic function. These are usually motor or operation commands that will have immediate effect (e.g. to turn on the motor, set a speed or activate digital output). See “Runtime Commands” on page 164 for the full list and description of these commands.

Runtime queries

These start with “?” when called via the serial communication (RS232 or USB), or using the getvalue() Microbasic function. These are used to read operating values at runtime (e.g. read Amps, Volts, power level, counter values). See “Runtime Commands” on page 164 for the full list and description of these commands.

Maintenance commands

These are only available through serial (RS232 or USB) and start with “%”. They are used for all of the maintenance commands such as (e.g. set the time, save configuration to EEPROM, reset, load default, etc.).

Set/Read Configuration commands

These start with “~” for read and “^” for write when called via the serial communication (RS232 or USB), or using the setcommand() MicroBasic function. They are used to read or configure all the operating parameters of the controller (e.g. set or read amps limit). See “Set/Read Configuration Commands” on page 194 for the full list and description of these commands.

Runtime Commands

Runtime commands are commands that can be sent at any time during controller operation and are taken into consideration immediately. Runtime commands start with “!” and are followed by one to three letters. Runtime commands are also used to refresh the watchdog timer to ensure safe communication. Runtime commands can be called from a MicroBasic script using the setcommand() function.

TABLE 19. Runtime Commands

Command	Arguments	Description
AC	Channel Acceleration	Set Acceleration
AX	Channel Acceleration	Next Acceleration
B	Variable Number Value	Set User Boolean Variable
BND	None	Spektrum Radio Bind
C	Channel Counter	Set Encoder Counters
CB	Counter	Set Brushless Counter
CS	Variable Number Data	CAN Send
D0	BitNumber	Reset Individual Digital Out bits
D1	BitNumber	Set Individual Digital Out bits
DC	Channel Deceleration	Set Deceleration
DS	Value	Set all Digital Out bits
DX	Channel Deceleration	Next Deceleration
EES	None	Save Configuration in EEPROM
EX	None	Emergency Shutdown
G	Channel Command	Set Motor Command
H	Channel	Load Home counter
MG	None	Release Shutdown
MS	Channel	Stop in All Modes
P	Channel Position	Set Position
PR	Channel Position	Go to Relative Desired Position
PRX	Channel Position	Next Go to Relative Desired Position
PX	Channel Position	Next Go to Absolute Desired Position
R	Mode	MicroBasic Run
S	Channel Velocity	Set Velocity
SX	Channel Velocity	Next Velocity
VAR	Variable Number Value	Set User Variable

AC - Set Acceleration

Set the rate of speed change during acceleration for a motor channel. This command is identical to the MACC configuration command but is provided so that it can be changed rapidly during motor operation. Acceleration value is in 0.1 * RPM per second. When using controllers fitted with encoder, the speed and acceleration value are actual RPMs. Brushless motor controllers use the hall sensor for measuring actual speed and acceleration will also be in actual RPM/s.

When using the controller without speed sensor, the acceleration value is relative to the Max RPM configuration parameter, which itself is a user-provided number for the speed normally expected at full power. Assuming that the Max RPM parameter is set to 1000, and acceleration value of 10000 means that the motor will go from 0 to full speed in exactly 1 second, regardless of the actual motor speed.

Syntax: **!AC nn mm**

Where: **nn** = motor channel
 mm = acceleration value in 0.1 * RPM/s

Examples: **!AC 1 2000** Increase Motor 1 speed by 200 RPM every second if speed is measured by encoder
 AC 2 20000 Time from 0 to full power is 0.5s if no speed sensors are present and Max RPM is set to 1000

AX - Next Acceleration

This command is used in Position Count mode. It is similar to AC except that it stores an acceleration value in a buffer. This value will become the next acceleration the controller will use and becomes active upon reaching a previous desired position. See "Position Command Chaining" on page 104.

Syntax: **!AX nn mm**

Where: **nn** = motor channel
 mm = acceleration value

Note: If omitted, the command will be chained using the last used acceleration value.

B - Set User Boolean Variable

Set the state of user boolean variables inside the controller. These variables can then be read from within a user MicroBasic script to perform specific actions.

Syntax: **!B nn mm**

Where: **nn** = variable number
 mm = 0 or 1 state

Note: The total number of user variables depends on the controller model and can be found in the product datasheet.

BND - Spektrum Radio Bind

This command is a duplication of the BIND maintenance command (See “BIND - Bind Spektrum Receiver” on page 190). It is provided as a Real-Time command as well in order to make it possible to initiate the Spektrum transmitter/receiver bind procedure from within MicroBasic scripts.

Syntax: **!BND**

C - Set Encoder Counters

This command loads the encoder counter for the selected motor channel with the value contained in the command argument. Beware that changing the controller value while operating in closed-loop mode can have adverse effects.

Syntax: **!C [nn] mm**

Where: **nn** = motor channel
 mm = counter value

Example: **!C 2 -1000** Loads -1000 in encoder counter 2
 !C 1 0 Clears encoder counter 1

CB - Set Brushless Counter

This command loads the brushless counter with the value contained in the command argument. Beware that changing the controller value while operating in closed-loop mode can have adverse effects.

Syntax: **!CB [nn] mm**

Where: **nn** = motor channel
 mm = counter value

Example: **!CB -1000** Loads -1000 in brushless counter
 !CB 0 Clears brushless counter

CS - CAN Send

This command is used in CAN-enabled controllers to build and send CAN frames in the RawCAN mode (See “Using RawCAN Mode” on page 118). It can be used to enter the header, bytecount, and data, one element at a time. The frame is sent immediately after the bytecount is entered, and so it should be entered last.

Syntax: **!CS ee nn**

Where: **ee** = frame element
 1 = header
 2 = bytecount
 3 to 10 = data0 to data7
 nn = value

Examples: **!CS 1 5** Enter 5 in header
 !CS 3 2 Enter 2 in Data 0

!CS 4 3 Enter 3 in Data 1
!CS 2 2 Enter 2 in bytecount. Send CAN data frame

D0 - Reset Individual Digital Out bits

The D0 command will turn off the single digital output selected by the number that follows.

Syntax: **!D0 nn**

Where: **nn** = output number

Examples: **!D0 2:** will turn output 2 to 0

D1 - Set Individual Digital Out bits

The D1 command will activate the single digital output that is selected by the parameter that follows.

Syntax: **!D1 nn**

Where: **nn** = output number

Examples: **!D1 1:** will turn ON output 1

DC - Set Deceleration

Same as AC but for speed changes from fast to slow.

Syntax: **!DC nn mm**

Where: **nn** = motor channel
 mm = deceleration value in 0.1 * RPM/s

Examples: **!DC 1 2000** Reduce Motor 1 speed by 200 RPM every second if speed is measured by encoder

!DC 2 20000 Time from full power to stop is 0.5s if no speed sensors are present and Max RPM is set to 1000

DS - Set all Digital Out bits

The D command will turn ON or OFF one or many digital outputs at the same time. The number can be a value from 0 to 255 and binary representation of that number has 1bit affected to its respective output pin.

Syntax: **!DS nn**

Where: **nn** = bit pattern to be applied to all output lines at once

Examples: **!DS 03:** will turn ON outputs 1 and 2. All others are off

DX - Next Deceleration

This command is used in Position Count mode. It is similar to DC except that it stores a deceleration value in a buffer. This value will become the next deceleration the controller will use and becomes active upon reaching a previous desired position. See "Position Command Chaining" on page 104.

Syntax: **!DX nn mm**

Where: **nn** = motor channel
mm = acceleration value

Note: If omitted, the command will be chained using the last used deceleration value.

EES - Save Configuration in EEPROM

This command is a duplication of the EESAV maintenance command (See "EESAV - Save Configuration in EEPROM" on page 191). It is provided as a Real-Time command as well in order to make it possible to save configuration changes from within MicroBasic scripts.

Syntax: **!EES**

Note: **Do not save configuration while motors are running. Saving to EEPROM takes several milliseconds, during which the control loop is suspended.**

EX - Emergency Stop

The EX command will cause the controller to enter an emergency stop in the same way as if hardware emergency stop was detected on an input pin. The emergency stop condition will remain until controller is reset or until the MG release command is received.

Syntax: **!EX**

G - Go to Speed or to Relative Position

G is the main command for activating the motors. The command is a number ranging -1000 to +1000 so that the controller respond the same way as when commanded using Analog or Pulse, which are also -1000 to +1000 commands. The effect of the command differs from one operating mode to another.

In Open Loop Speed mode the command value is the desired power output level to be applied to the motor.

In Closed Loop Speed mode, the command value is relative to the maximum speed that is stored in the MXRPM configuration parameter.

In Closed Loop Position Relative and in the Closed Loop Tracking mode, the command is the desired relative destination position mode.

The G command has no effect in the Position Count mode.

In the Torque mode, the command value is the desired Motor Amps relative to the Amps Limit configuration parameters

Syntax: **!G [nn] mm**

Where: **nn** = motor channel
mm = command value

Examples: **G 1 500:**

In Open Loop Speed mode, applies 50% power to the motors

In Closed Loop Speed mode, assuming that 3000 is contained in Max RPM parameter (MXRPM), motor will go to 1500 RPM

In Closed Loop Relative or Closed Loop Tracking modes, the motor will move to 75% position of the total -1000 to +1000 motion range

In Torque mode, assuming that Amps Limit is 60A, motor power will rise until 30A are measured.

H - Load Home Counter

This command loads the Home count value into the Encoder or Brushless Counters. The Home count can be any user value and is set using the EHOME and BHOME configuration parameters. When sent without argument, the command loads all counters for all motors with their preset value. When sent with an argument, the argument selects the motor channel. Beware that loading the counter with the home value while the controller is operating in closed loop can have adverse effects.

Syntax: **!H [nn]**

Where: **nn** = motor channel

Examples: **!H 1:** loads encoder counter 1 and brushless counter 1 with their preset home values
!H 2: loads encoder counter 2 and brushless counter 2 with their preset home values

MG - Emergency Stop Release

The MG command will release the emergency stop condition and allow the controller to return to normal operation.

Syntax: **!MG**

MS - Stop in All Modes

The MS command is similar to the EX command except that it is applied to the specified motor channel (see "EX - Emergency Stop" on page 168).

Syntax: **!MS [nn]**

Where: **nn** = motor channel

P - Go to Absolute Desired Position

This command is used in the Position Count mode to make the motor move to a specified encoder count value.

Syntax: **!P [nn] mm**

Where: **nn** = motor channel
mm = absolute count destination

Example: **!P 1 10000:** make motor go to absolute count value 10000.

PR - Go to Relative Desired Position

This command is used in the Position Count mode to make the motor move to an encoder count position that is relative to its current desired position.

Syntax: **PR [nn] cc**

Where: **nn** = motor channel
cc = relative count position

Examples: **!PR 1 10000** while motor is stopped after power up and counter = 0, motor 1 will go to +10000

!PR 2 10000 while previous command was absolute goto position **!P 2 5000**, motor will go to +15000

Note: Beware that counter will rollover at counter values +/-2¹⁴⁷483⁶⁴⁸.

PRX - Next Go to Relative Desired Position

This command is similar to PR except that it stores a relative count value in a buffer. This value becomes active upon reaching a previous desired position and will become the next destination the controller will go to. See "Position Command Chaining" on page 104.

Syntax: **!PRX [nn] cc**

Where: **nn** = motor channel
cc = relative count position

Example: **!P 1 5000** followed by **!PRX 1 -10000** will cause motor to go to count position 5000 and upon reaching the destination move to position -5000.

PX - Next Go to Absolute Desired Position

This command is similar to P except that it stores an absolute count value in a buffer. This value will become the next destination the controller will go to and becomes active upon reaching a previous desired position. See "Position Command Chaining" on page 104.

Syntax: **!PX [nn] cc**

Where: **nn** = motor channel
cc = absolute count position

Example: **!P 1 5000** followed by **!PX 1 -10000** will cause motor to go to count position 5000 and upon reaching the destination move to position -10000.

R - MicroBasic Run

This command is used to start, stop and restart a MicroBasic script if one is loaded in the controller.

Syntax: **!R [nn]**

Where: **nn = empty:** start/resume script
 nn = 1: same as above
 nn = 0: stop script
 nn = 2: reinitialize and start script

S - Motor Position-Mode Velocity

This runtime command accepts actual RPM values and works in the closed-loop Position Relative and Count Position modes. It determines the speed at which the motor should move from one position to the next. This command requires two arguments: the first to select the motor channel, the second to set the velocity. The motor channel may be omitted in single channel controllers. The velocity is set in actual RPMs in system with speed sensor (encoder or brushless hall sensors). In systems without speed sensors, the velocity parameter will be relative to the Max RPM configuration parameter.

Syntax: **!S [nn] mm**

Where: **nn** = motor channel
 mm = speed value in RPM

Examples: **!S 2500:** set motor1 position velocity to 2500 RPM
 !S 1 2500: set motor1 position velocity to 2500 RPM

SX - Next Velocity

This command is used in Position Count mode. It is similar to S except that it stores a velocity value in a buffer. This value will become the next velocity the controller will use and becomes active upon reaching a previous desired position. See "Position Command Chaining" on page 104.

Syntax: **!SX nn mm**

Where: **nn** = motor channel
 mm = velocity value

Note: If omitted, the command will be chained using the last used velocity value.

VAR - Set User Integer Variable

This command is used to set the value of user variables inside the controller. These variables can be then read from within a user MicroBasic script to perform specific actions. The total number of variables depends on the controller model and can be found in the product datasheet. Variables are signed 32-bit integers.

Syntax: **!VAR nn mm**

Where: **nn** = variable number
 mm = value

Runtime Queries

Runtime queries can be used to read the value of real-time measurements at any time during the controller operation. Real-time queries are very short commands that start with “?” followed by one to three letters. In some instances, queries can be sent with or without a numerical parameter.

Without parameter, the controller will reply with the values of all channels. When a numerical parameter is sent, the controller will respond with the value of the channel selected by that parameter.

Example: Q: ?T
 R: T=20:30:40

 Q: ?T2
 R: T=30

All queries are stored in a history buffer that can be made to automatically recall the past 16 queries at a user-selectable time interval. See “Query History Commands” on page 188.

Runtime queries can be sent from within a MicroBasic script using the `getvalue()` function.

TABLE 20. Runtime Queries

Command	Arguments	Description
A	InputNbr	Read Motor Amps
AI	InputNbr	Read Analog Inputs
AIC	InputNbr	Read Analog Input after Conversion
B	Variable Number	Read User Boolean Variable
BA	InputNbr	Read Battery Amps
BS	None	Read BL Motor Speed in RPM
BSR	None	Read BL Motor Speed as 1/1000 of Max
C	Channel	Read Absolute Encoder Count
CAN	Variable Number	Read Raw CAN frame
CB	None	Read Absolute Brushless Counter
CBR	None	Read Brushless Count Relative
CF	Channel	Read Raw CAN Received Frames Count
CIA	Channel	Read Internal Analog Command
CIP	Channel	Read Internal Pulse Command
CIS	Channel	Read Internal Serial Command
CR	Channel	Read Encoder Count Relative
D	InputNbr	Read All Digital Inputs
DI	InputNbr	Read Individual Digital Inputs
DO	None	Read Current Digital Outputs
DR	Channel	Read Destination Reached
E	None	Read Closed Loop Error
F	None	Read Feedback

TABLE 20. Runtime Queries

Command	Arguments	Description
FF	None	Read Fault Flags
FID	None	Read Firmware ID String
FM	Channel	Reading Runtime Status of Each Motor
FS	None	Read Status Flags
K	Channel	Read Spektrum Receiver
LK	None	Read Lock status
M	Channel	Read Actual Motor Command
MA	Sensor Number	Read MEMS Accelerometers
MGD	None	Read Magsensor Track Detect
MGM	Channel	Read Magsensor Markers
MGS	None	Read Magsensor Status
MGT	Channel	Read Magsensor Track Position
P	Channel	Read Applied Power Level
PI	InputNbr	Read Pulse Inputs
PIC	Channel	Read Pulse Input after Conversion
S	Channel	Read Encoder Motor Speed in RPM
SR	Channel	Read Encoder Motor Speed as 1/1000 of Max
T	Sensor Number	Read Case & Internal Temperatures
TM	Channel	Read Time
TR	Channel	Read Position Relative Tracking
TRN	None	Read Power Unit Tree filename
V	Sensor Number	Read Internal Voltages
VAR	Variable Number	Read User Variable

A - Read Motor Amps

Measures and reports the motor Amps for all operating channels. Note that the current flowing through the motors is often higher than this flowing through the battery.

Syntax: **?A [cc]**

Reply: **A = aa**

Where: **cc** = motor channel
 aa = Amps *10 for each channel

Examples: Q: **?A**
 R: **A=100:200**

 Q: **?A 2**
 R: **A=200**

Notes: Single channel controllers will report a single value. Sepex controllers report the motor Amps and the Field excitation Amps.

Some power board units measure the Motor Amps and calculate the Battery Amps, while other models measure the Battery Amps and calculate the Motor Amps. The measured Amps is always more precise than the calculated Amps. See controller datasheet to find which Amps is measured by your particular model.

AI - Read Analog Input

Reports the raw value in mV of each of the analog inputs that are enabled. Input that is disabled will report 0.

Syntax: **?AI [cc]**

Reply: **AI=nn**

Where: **cc** = Analog Input number
nn = millivolt for each channel

Allowed Range: 0 to 5000mV

Notes: The total number of Analog input channels varies from one controller model to another and can be found in the product datasheet.

AIC - Read Analog Input after Conversion

Returns value of an Analog input after all the adjustments are performed to convert it to a command or feedback value (Min/Max/Center/Deadband/Linearity). If an input is disabled, the query returns 0.

Syntax: **?AIC**

Reply: **AIC=nn**

Where: **nn** = Converted analog input value +/-1000 range

B - Read User Boolean Variable

Read the value of boolean internal variables that can be read and written to/from within a user MicroBasic script. It is used to pass boolean states between user scripts and a micro-computer connected to the controller.

Syntax: **?B nn**

Reply: **B=bb**

Where: **nn** = boolean variable number
bb = 0 or 1 state of the variable

Note: The total number of user boolean variables varies from one controller model to another and can be found in the product datasheet.

BA - Read Battery Amps

Measures and reports the Amps flowing from the battery. Battery Amps are often lower than motor Amps.

Syntax: **?BA [cc]**

Reply: **BA=aa**

Where: **cc** = motor channel
 aa = Amps *10 for each channel

Examples: Q: **?BA**
 R: **BA=100:200**

Notes: Single channel controllers will report a single value. Sepex controllers report a single value with the battery current for both the Armature and Field excitation.

Some power board units measure the Motor Amps and Calculate the Battery Amps, while other models measure the Battery Amps and calculate the Motor Amps. The measured Amps is always more precise than the calculated Amps. See controller datasheet to find which Amps is measured by your particular model.

BS - Read BL Motor Speed in RPM

On brushless motor controllers, reports the actual speed measured using the motor's Hall sensors as the actual RPM value.

Syntax: **?BS**

Reply: **BS=nn**

Where: **nn** = speed in RPM

Notes: To report RPM accurately, the correct number of motor poles must be loaded in the BLPOL configuration parameter.

BSR - Read BL Motor Speed as 1/1000 of Max

On brushless motor controllers, returns the measured motor speed as a ratio of the Max RPM configuration parameter (See "MXRPM - Max RPM Value" on page 221). The result is a value of between 0 and +/-1000. Note that if the motor spins faster than the Max RPM, the return value will exceed 1000. However, a larger value is ignored by the controller for its internal operation.

Syntax: **?BSR**

Reply: **BSR=nn**

Where: **nn** = speed relative to max

Example: Q: **?BSR**
 R: **BSR=500**: speed is 50% of the RPM value stored in the Max RPM configuration

Notes: To report an accurate result, the correct number of motor poles must be loaded in the BLPOL configuration parameter.

C - Read Encoder Counter Absolute

Returns the encoder value as an absolute number. The counter is a 32-bit counter with a range of +/- 2000000000 counts.

Syntax: **?C [cc]**

Reply: **C=nn**

Where: **cc** = channel number
nn = absolute counter value

CAN - Read Raw CAN frame

This query is used in CAN-enabled controllers to read the content of a received CAN frame in the RawCAN mode (See "Using RawCAN Mode" on page 118). Data will be available for reading with this query only after a ?CF query is first used to check how many received frames are pending in the FIFO buffer. When the query is sent without arguments, the controller replies by outputting all elements of the frame separated by colons.

Syntax: **?CAN [ee]**

Reply: **CAN=header:bytecount:data0:data1: :data7**

Where: **ee** = frame element
1 = header
2 = bytecount
3 to 10 = data0 to data7

Examples: Q: **?CAN**
 R: **CAN=5:4:11:12:13:14:0:0:0**

Q: **?CAN 3**
 R: **CAN=11**

CB - Read Absolute Brushless Counter

On brushless motor controllers, returns the running total of Hall sensor transition value as an absolute number. The counter is a 32-bit counter with a range of +/- 2000000000 counts.

Syntax: **?CB**

Reply: **CB=nn**

Where: **nn** = absolute counter value

CBR - Read Brushless Count Relative

On brushless motor controllers, returns the number of Hall sensor transition value that have been measured from the last time this query was made. Relative counter read is sometimes easier to work with, compared to full counter reading, as smaller numbers are usually returned.

Syntax: **?CBR**

Reply: **CBR=nn**

Where: **nn** = counts since last read

CF - Read Raw CAN Received Frames Count

This query is used to read the number of received CAN frames pending in the FIFO buffer and copies the oldest frame into the read buffer, from which it can then be accessed. Sending ?CF again, copies the next frame into the read buffer.

Syntax: **?CF**

Reply: **CF=nn**

Where: **nn** = number of frames pending

CIA - Read Internal Analog Command

Returns the motor command value that is computed from the Analog inputs whether or not the command is actually applied to the motor. This query can be used, for example, to read the command joystick from within a MicroBasic script or from an external microcomputer, even though the controller may be currently responding to RS232 or Pulse command because of a higher priority setting. The returned value is the raw Analog input value with all the adjustments performed to convert it to a command (Min/Max/Center/Deadband/Linearity).

Syntax: **?CIA**

Reply: **CIA=nn**

Where: **nn** = command value in +/-1000 range

CIP - Read Internal Pulse Command

Returns the motor command value that is computed from the Pulse inputs whether or not the command is actually applied to the motor. This query can be used, for example, to read the command joystick from within a MicroBasic script or from an external microcomputer, even though the controller may be currently responding to RS232 or Analog command because of a higher priority setting. The returned value is the raw Pulse input value with all the adjustments performed to convert it to a command (Min/Max/Center/Deadband/Linearity).

Syntax: **?CIP**

Reply: **CIP=nn**

Where: **nn** = command value in +/-1000 range

CIS - Read Internal Serial Command

Returns the motor command value that is issued from the serial input or from a MicroBasic script whether or not the command is actually applied to the motor. This query can be used, for example, to read from an external microcomputer the command generated inside MicroBasic script, even though the controller may be currently responding to a Pulse or Analog command because of a higher priority setting.

Syntax: **?CIS**

Reply: **CIS=nn**

Where: **nn** = command value in +/-1000 range

CR - Read Encoder Counter Relative

Returns the amount of counts that have been measured from the last time this query was made. Relative counter read is sometimes easier to work with, compared to full counter reading, as smaller numbers are usually returned.

Syntax: **?CR [cc]**

Reply: **CR=nn**

Where: **cc** = channel number
 nn = counts since last read

D - Read Digital Inputs

Reports the status of each of the available digital inputs. The query response is a single digital number which must be converted to binary and gives the status of each of the inputs.

Syntax: **?D [cc]**

Reply: **D=nn**

Where: **cc** = Digital Input number
 nn = $b_1 + b_2 * 2 + b_3 * 4 + \dots + b_n * 2^{n-1}$

Examples: Q: **?D**
 R: **D=17** : Inputs 1 and 5 active, all others inactive

Notes: The total number of Digital input channels varies from one controller model to another and can be found in the product datasheet.

DI - Read Individual Digital Inputs

Reports the status of an individual Digital Input. The query response is a boolean value (0 or 1).

Syntax: **?DI [cc]**

Reply: **DI=nn**

Where:	cc = Digital Input number nn = 0 or 1 state for each input
Examples:	Q: ?DI R: DI=1:0:1:0:1:0 Q: ?DI 1 R: DI=0
Notes:	The total number of Digital input channels varies from one controller model to another and can be found in the product datasheet.

DO - Read Digital Output Status

Reads the actual state of all digital outputs. The response to that query is a single number which must be converted into binary in order to read the status of the individual output bits.

Syntax:	?DO [cc]
Reply:	DO=nn
Where:	cc = Digital Input number nn = $d1 + d2*2 + d3*4 + \dots + dn * 2^{n-1}$
Examples:	Q: ?DO R: DO=17 : Outputs 1 and 5 active, all others inactive Q: ?DO 1 R: DO=1 : Queried output 1 is active
Notes:	When querying an individual output, the reply is 0 or 1 depending on its status. The total number of Digital output channels varies from one controller model to another and can be found in the product datasheet.

DR - Read Destination Reached

This query is used when chaining commands in Position Count mode, to detect that a destination has been reached and that the next destination values that were loaded in the buffer have become active. See "Position Command Chaining" on page 104.

E - Read Closed Loop Error

In closed-loop modes (Speed or Position), returns the difference between the desired speed or position and the measured feedback. This query can be used to detect when the motor has reached the desired speed or position. In open loop mode, this query returns 0.

Syntax:	?E
Reply:	E=nn
Where:	nn = error

F - Read Feedback In

Reports the value of the feedback sensors that are associated to each of the channels in closed-loop modes. The feedback source can be Encoder, Analog or Pulse. Selecting the feedback source is done in the encoder, pulse or analog configuration parameters. This query is useful for verifying that the correct feedback source is used by the channel in the closed-loop mode and that its value is in range with expectations.

Syntax: **?F [cc]**

Reply: **F=nn**

Where: **cc** =channel number
nn = feedback values

FF - Read Fault Flag

Reports the status of the controller fault conditions that can occur during operation. The response to that query is a single number which must be converted into binary in order to evaluate each of the individual status bits that compose it.

Syntax: **?FF [cc]**

Reply: **FF = f1 + f2*2 + f3*4 + ... + fn*2ⁿ⁻¹**

Where: **f1** = overheat
f2 = overvoltage
f3 = undervoltage
f4 = short circuit
f5 = emergency stop
f6 = Sepex excitation fault
f7 = MOSFET failure
f8 = startup configuration fault

FID - Read Firmware ID

This query will report a string with the date and identification of the firmware revision of the controller.

Syntax: **?FID**

Reply: **FID=Firmware ID string**

Example: Q: **?FID**
R: **FID=Roboteq v1.2 RCB200 05/01/2012**

FM - Read Runtime Status Flag

Report the runtime status of each motor. The response to that query is a single number which must be converted into binary in order to evaluate each of the individual status bits that compose it.

Syntax: **?FM [nn]**

Reply: **FM = f1 + f2*2 + f3*4 + ... + fn*2ⁿ⁻¹**

Where: **nn** = Motor channel
 f1 = Amps Limit currently active
 f2 = Motor stalled
 f3 = Loop Error detected
 f4 = Safety Stop active
 f5 = Forward Limit triggered
 f6 = Reverse Limit triggered
 f7 = Amps Trigger activated

Notes: **f2**, **f3** and **f4** are cleared when the motor command is returned to 0.
 When **f5** or **f6** are on, the motor can only be commanded to go in the reverse direction.

FS - Read Status Flag

Report the state of status flags used by the controller to indicate a number of internal conditions during normal operation. The response to this query is the single number for all status flags. The status of individual flags is read by converting this number to binary and look at various bits of that number.

Syntax: **?FS**

Reply: **FS** = $f1 + f2*2 + f3*4 + \dots + fn*2^{n-1}$

Where: **f1** = Serial mode
 f2 = Pulse mode
 f3 = Analog mode
 f4 = Power stage off
 f5 = Stall detected
 f6 = At limit
 f7 = Unused
 f8 = MicroBasic script running

On controller models supporting Spektrum radio mode the status flags are shifted as follows:

f1 = Serial mode
f2 = Pulse mode
f3 = Analog mode
f4 = Spektrum mode
f5 = Power stage off
f6 = Stall detected
f7 = At limit
f8 = MicroBasic script running

K - Read Spektrum Receiver

On controller models with Spektrum radio support, this query is used to read the raw values of each of up to 6 receive channels. When signal is received, this query returns the value 0.

Syntax: **?K nn**

Where: **nn** = radio channel

Reply: **K=nn**

Where: **nn** = raw joystick value, or 0 if transmitter is off or out of range

LK - Read Lock Status

Returns the status of the lock flag. If the configuration is locked, then it will not be possible to read any configuration parameters until the lock is removed or until the parameters are reset to factory default. This feature is useful to protect the controller configuration from being copied by unauthorized people.

Syntax: **?LK**

Reply: **LK=ff**

Where: **ff** = 0 : unlocked
1 : locked

M - Read Motor Command Applied

Reports the command value that is being used by the controller. The number that is reported will be depending on which mode is selected at the time. The choice of one command mode vs. another is based on the command priority mechanism described at "Command Priorities" on page 114.

In the RS232 mode, the reported value will be the command that is entered in via the RS232 or USB port and to which an optional exponential correction is applied.

In the Analog and Pulse modes, this query will report the Analog or Pulse input after it is being converted using the min, max, center, deadband, and linearity corrections.

This query is useful for viewing which command is actually being used and the effect of the correction that is being applied to the raw input.

Syntax: **?M [cc]**

Reply: **M=nn**

Where: **cc** = channel number
nn = command value used for each motor. 0 to ± 1000 range

Examples: Q: **?M**
R: **M=800:-1000**

Q: **?M 1**
R: **M=800**

MA - Read MEMS Accelerometers

On controllers fitted with a 3-axis MEMS accelerometer, this query can be used to read the value along each axis.

Syntax: **?MA nn**

Reply: **MA=mm**

Where: **nn** = axis number
 mm = acceleration value

Examples: Q: **?MA**
 R: **MA=100:200:300** Returns X, Y and Z acceleration values

 Q: **?MA 3**
 R: **MA=200** Returns Y acceleration value

MGD - Read Magsensor Track Detect

Reports whether a magnetic tape is within the range of the magnetic sensor. If no tape is detected, the output will be 0.

Syntax: **?MGD**

Reply: **MGD=nn**

Where: **nn** = 0 : no track detected
 nn = 1 : track detected

MGM - Read Magsensor Markers

Reports whether a marker is detected within the range of the magnetic sensor.

Syntax: **?MGM [nn]**

Reply: **MGM=mm**

Where: **nn** = Marker number
 nn = 1 : Left Marker
 nn = 2 : Right Marker
 mm = 0 : No marker detected
 mm = 1 : Marker detected

MGS - Read Magsensor Status

Returns a single number with general status information about the sensor. This query can be used to detect that a sensor is present and operational.

Syntax: **?MGS**

Reply: **MGS=f1 + f2*2 + f3*4 + ... + fn*2ⁿ⁻¹**

Where: **f1** : Tape detect
 f2 : Left marker present
 f3 : Right marker present
 f9 : Sensor active

MGT - Read Magsensor Track Position

Reports the position of the magnetic track in millimeters, using the center of the sensor as the 0 reference.

Syntax: **?MGM [nn]**

Reply: **MGM**=mm
Where: **nn** = track number
mm = position in millimeters

P - Read Motor Power Output Applied

Reports the actual power that is being applied to the motor at the power output stage. This value takes into account all the internal corrections and any limiting resulting from temperature or over current.

Syntax: **?P [cc]**
Reply: **P**=p1;p2
Where: **cc** = motor channel
p1, p2 = 0 to ± 1000 power level
Examples: Q: **?P 1**
R: **P=800**
Notes: For Sepex controllers this query will report the applied power on the Armature and Field excitation.

PI - Read Pulse Input

Reports the value of each of the enabled pulse input captures. The value is the raw number in microseconds when configured in Pulse Width mode. In Frequency mode, the returned value is in Hertz. In Duty Cycle mode, the reported value ranges between 0 and 4095 when the pulse duty cycle is 0% and 100% respectively.

Syntax: **?PI [cc]**
Reply: **PI**=nn
Where: **cc** = Pulse capture channel number
nn = value *each channel
Allowed Range: 0 to 65000 μ s
Notes: The total number of Pulse input channels varies from one controller model to another and can be found in the product datasheet.

PIC - Read Pulse Input after Conversion

Returns value of a Pulse input after all the adjustments were performed to convert it to a command or feedback value (Min/Max/Center/Deadband/Linearity). If an input is disabled, the query returns 0.

Syntax: **?AIC**
Reply: **AIC**=nn
Where: **nn** = Converted analog input value +/-1000 range

S - Read Encoder Speed RPM

Reports the actual speed measured by the encoders as the actual RPM value.

Syntax: **?S [cc]**

Reply: **S =vv:vv**

Where: **cc** = channel number
vv = speed in RPM

Notes: To report RPM accurately, the correct Pulses per Revolution (PPR) must be stored in the encoder configuration.

SR - Read Encoder Speed Relative

Returns the measured motor speed as a ratio of the Max RPM configuration parameter (see "MXRPM - Max RPM Value" on page 221). The result is a value of between 0 and +/- 1000. As an example, if the Max RPM is set at 3000 inside the encoder configuration parameter and the motor spins at 1500 RPM, then the returned value to this query will be 500, which is 50% of the 3000 max. Note that if the motor spins faster than the Max RPM, the returned value will exceed 1000. However, a larger value is ignored by the controller for its internal operation.

Syntax: **?SR [cc]**

Reply: **SR=vv:vv**

Where: **cc** = channel number
vv = speed relative to max

T - Read Temperature

Reports the temperature at each of the Heatsink sides and on the internal silicon chips. The reported value is in degrees C with a one degree resolution.

Syntax: **?T [cc]**

Reply: **T=tm:t1:t2**

Where: **cc** = temperature channel
tm = internal ICs
t1 = channel1 side
t2 = channel2 side

Notes: On some controller models, additional temperature values are reported. These are measured at different interval points and not documented. You may safely ignore this extra data. Other controller models only have one heatsink temperature sensor and therefore only report one value in addition to the Internal IC temperature.

TM - Read Time

Reports the value of the time counter in controller models equipped with Real-Time clocks. Note that time is kept whether the controller is On or Off but only if the controllers is con-

nected to a power supply. Time is counted in a 32-bit counter and the returned value can be converted into a full day and time value using external calculation.

Syntax: **?TM**

Reply: **TM**=number of seconds in counter

TR - Read Position Relative Tracking

Reads the value of the expected motor position in the position tracking closed loop mode.

Syntax: **?TR [nn]**

Reply: **TR**=mm

Where: **nn** = motor channel
mm = relative count position

TRN - Read Control Unit type and Controller Model

Reports two strings identifying the Control Unit type and the Controller Model type. This query is useful for adapting the user software application to the controller model that is attached to the computer.

Syntax: **?TRN**

Reply: **TRN**=Control Unit Id String:Controller Model Id String

Example: Q: **?TRN**
R: **TRN=RCB500:HDC2450**

V - Read Volts

Reports the voltages measured inside the controller at three locations: the main battery voltage, the internal voltage at the motor driver stage, and the voltage that is available on the 5V output on the DSUB 15 or 25 front connector. For safe operation, the driver stage voltage must be above 12V. The 5V output will typically show the controller's internal regulated 5V minus the drop of a diode that is used for protection and will be in the 4.7V range. The battery voltage is monitored for detecting the undervoltage or overvoltage conditions.

Syntax: **?V [cc]**

Reply: **V**=vdr:vmot:v5out

Where: **vdr** = internal voltage in Volts * 10
vmot = main battery voltage in Volts * 10
v5out = 5V output on DSub connector in millivolts

Examples: Q: **?V**
R: **V=135:246:4730**

Q: **?V 3**
R: **V=4730**

VAR - Read User Integer Variable

Read the value of dedicated 32-bit internal variables that can be read and written to/from within a user MicroBasic script. It is used to pass 32-bit signed number between user scripts and a microcomputer connected to the controller.

Syntax: **?VAR [nn]**

Reply: **VAR=mm**

Where: **nn** = variable number
 mm = variable value

Note: The total number of user integer variables varies from one controller model to another and can be found in the product datasheet.

Query History Commands

Every time a Real Time Query is received and executed, it is stored in a history buffer from which it can be recalled. The buffer will store up to 16 queries. If more than 16 queries are received, the new one will be added to the history buffer while the firsts are removed in order to fit the 16 query buffer.

Queries can then be called from the history buffer using manual commands, or automatically, at user selected intervals. This feature is very useful for monitoring and telemetry.

Additionally, the history buffer can be loaded with a set of user selected queries at power on so that the controller can automatically issue operating values immediately after power up. See "TELS - Telemetry String" on page 198 for detail on how to set up the startup Telemetry string.

A command set is provided for managing the history buffer. These special commands start with a "#" character.

TABLE 21. Query History Commands

Command	Description
#	Send the next value. Stop automatic sending
# C	Clear buffer history
# nn	Start automatic sending

- Send Next History Item / Stop Automatic Sending

A # alone will call and execute the next query in the buffer. If the controller was in the process of automatically sending queries from the buffer, then receiving a # will cause the sending to stop.

When a query is executed from the history buffer, the controller will only display the query result (e.g. A=10:20). It will not display the query itself.

Syntax: #

Reply: QQ

Where: QQ = is reply to query in the buffer.

C - Clear Buffer History

This command will clear the history buffer of all queries that may be stored in it. If the controller was in the process of automatically sending queries from the buffer, then receiving this command will also cause the sending to stop

Syntax: # C

Reply: None

nn - Start Automatic Sending

This command will initiate the automatic retrieving and execution of queries from the history buffer. The number that follows the command is the time in milliseconds between repetition. A single query is fetched and executed at each time interval.

Syntax: **# nn**

Reply: **QQ** at every nn time intervals

Where: **QQ** = is reply to query in the buffer.
 nn = time in ms

Range: **nn** = 1 to 32000ms

Maintenance Commands

This section contains a few commands that are used occasionally to perform maintenance functions.

TABLE 22. Maintenance Commands

Command	Argument	Description
BIND	None	Bind Spektrum Receiver
DFU	Key	Enter Firmware Update via USB
EELD	None	Load Parameters from EEPROM
EERST	Key	Restore Factory Defaults
EESAV	None	Save Parameters to EEPROM
LK	Key	Lock Configuration read
RESET	Channel Key	Reset Controller
STIME	Hours Mins Secs	Set Time
UK	Key	Unlock Configuration read

BIND - Bind Spektrum Receiver

This maintenance command is used to make the receiver enter the Bind mode, so that it can be paired with a matching transmitter. This command is only for use on controller models equipped with a connector for a Spektrum brand SPM9545 satellite receiver. Binding is done following this sequence:

- 1- Disconnect the 3-pin Spektrum receiver cable from the controller.
- 2- Send the **%BIND** command.
- 3- Immediately replug the receiver. Maximum allowed time is around 2s, or until the + is returned by the controller. The receiver LED will be flashing.
- 4- Turn on the transmitter while holding the bind switch. The receiver LED will stop flashing and remain on, indicating that the Binding was successful.

DFU - Update Firmware via USB

Firmware update can be performed via the RS232 port or via USB. When done via USB, the DFU command is used to cause the controller to enter in the firmware upgrade mode. This command must be used with care and must be followed by a 9-digit safety key to prevent accidental use.

Once the controller has received the DFU command, it will no longer respond to the PC utility and no longer be visible on the PC. When this mode is entered, you must launch the separate upgrade utility to start the firmware upgrade process.

Syntax: **%DFU safetykey**

Where: **safetykey** = 321654987

Example: **%DFU 321654987**

EELD - Load Parameters from EEPROM

This command reloads the configuration that are saved in EEPROM back into RAM and activates these settings.

Syntax: **%EELD**

EERST - Reset Factory Defaults

The EERST command will reload the controller's RAM and EEPROM with the factory default configuration. Beware that this command may cause the controller to no longer work in your application since all your configurations will be erased back to factory defaults. This command must be used with care and must be followed by a 9-digit safety key to prevent accidental use.

Syntax: **%EERST safetykey**

Where: **safetykey = 321654987**

Example: **%EERST 321654987**

EESAV - Save Configuration in EEPROM

Controller configuration that have been changed using any Configuration Command can then be saved in EEPROM. Once in EEPROM, it will be loaded automatically in the controller every time the unit is powered on. If the EESAV command is not called after changing a configuration, the configuration will remain in RAM and active only until the controller is turned off. When powered on again, the previous configuration that was in the EEPROM is loaded. This command uses no parameters

Syntax: **%EESAV**

Notes: **Do not save configuration while motors are running. Saving to EEPROM takes several milliseconds, during which the control loop is suspended.**

LK - Lock Configuration Access

This command is followed by a user-selected secret 32-bit number. After receiving it, the controller will lock the configuration and store the key inside the controller, in area which cannot be accessed. Once locked, the controller will no longer respond to configuration reads. However, it is still possible to store or to set new configurations.

Syntax: **%LK secretkey**

Where: **secretkey = 32-bit number (1 to 4294967296)**

Examples: **%LK 12345**
 %LK 2343567345

Notes: The controller must be unlocked for this command to work. The 0 value is reserved as the "unlocked" key.

RESET - Reset Controller

This command will cause the controller to reset similarly as if it was powered OFF and ON. This command must be used with care and must be followed by a 9-digit safety key to prevent accidental reset.

Syntax: **%RESET safetykey**

Where: **safetykey** = 321654987

Example: **%RESET 321654987**

STIME - Set Time

This command sets the time inside the controller's clock that is available in some controller models. The clock circuit will then keep track of time as long as the clock remains under power. The clock is a single 32-bit counter in which the number of seconds from a preset day and time is stored (for example 02/01/00 at 3:00).

Syntax: **%STIME nn**

Where: **nn** = number of seconds

UK - Unlock Configuration Access

This command will release the lock and make the configuration readable again. The command must be followed by the secret key which will be matched by the controller internally against the key that was entered with the LK command to lock the controller. If the keys match, the configuration is unlocked.

Syntax: **!UK secretkey**

Where: **secretkey** = 32-bit number (1 to 4294967296)

Examples: **%UK 12345**
 %UK 2343567345

Flash Card Maintenance Commands

This section describes the maintenance commands that may be used to read and manage the content of memory cards on controllers supporting MicroSD Cards. The cards content is stored using the NTFS file format and can therefore also be plugged in a PC as well for reading/writing the files.

TABLE 23. Flash Card Maintenance Commands

Command	Argument	Description
SDEL	None	Clear SD Card file
SDIR	Filename	Read SD Card directory
SREAD	Filename	Read SD Card file

SDIR - List Files Stored on Card

This command displays the list of files that exist on the card.

Syntax: **%SDIR**

Reply: LOG000001.TXT
 LOG000002.TXT
 ...

SREAD - Read the Content of a File

This command will dump on the console the text content of a specified file.

Syntax: **%SREAD filename**

Reply: Dump of all characters contained in the file onto the console screen

SDEL - Delete File

Erase a file physically from the SD Card.

Syntax: **%SDEL filename**

Reply: + if command was successful

Set/Read Configuration Commands

These commands are used to set or read all the operating parameters needed by the controller for its operation. Parameters are loaded from EEPROM into RAM, from where they are and then used every time the controller is powered up or restarted.

Important Notices

The total number of configuration parameters is very large. To simplify the configuration process and avoid errors, it is highly recommended to use the RoborunPlus PC utility to read and set configuration.

Some configuration parameters may be absent depending on the presence or absence of the related feature on a particular controller model.

Setting Configurations

The general format for setting a parameter is the “^” character followed by the command name followed by parameter(s) for that command. These will set the parameter in the controller’s RAM and this parameter becomes immediately active for use. The parameter can also be permanently saved in EEPROM by sending the **%EESAV** maintenance command.

Some parameters have a unique value that applies to the controller in general. For example, overvoltage or PWM frequency. These configuration commands are therefore followed by a single parameter:

^PWM 180 : Sets PWM frequency to 18.0 kHz

^OVL 400 : Sets Overvoltage limit to 40.0V

Other parameters have multiple value, with typically one value applying to a different channel. Multiple value parameters are numbered from 1 to n. For example, Amps limit for a motor channel or the configuration of an analog input channel.

^ALIM 1 250 : Sets Amps limit for channel 1 to 25.0A

^AMIN 4 2000 : Sets low range of analog input 4 to 2000

Using 0 as the first parameter value will cause all elements to be loaded with the same content.

^ADB 0 10 : Sets the deadband of all analog inputs to 10%

Important Notice

Saving configuration into EEPROM can take up to 20ms per parameter. The controller will suspend the loop processing during this time, potentially affecting the controller operation. Avoid saving configuration to EEPROM during motor operation.

Reading Configurations

Configuration parameters are read by issuing the “~” character followed by the command name and with an optional channel number parameter. If no parameter is sent, the controller will give the value of all channels. If a channel number is sent, the controller will give the value of the selected channel.

The reply to parameter read command is the command name followed by "=" followed by the parameter value. When the reply contains multiple values, then the different values are separated by ":". The list below describes every configuration command of the controller. For example:

~ALIM : Read Amps limit for all channels

Reply: **ALIM= 750:650**

~ALIM 2: Read Amps limit for channel 2

Reply: **ALIM= 650**

Configuration parameters can be read from within a MicroBasic script using the getconfig() function. The setconfig() function is used to load a new value in a configuration parameter.

Important Warning

Configuration commands can be issued at any time during controller operation. Beware that some configuration parameters can alter the motor behavior. Change configurations with care. Whenever possible, change configurations while the motors are stopped.

Configuration Read Protection

The controller may be locked to prevent the configuration parameters to be read. Given the large number of possible configurations, this feature provides effective system-level copy protection. The controller will reply to configuration read requests only if the read protection is unlocked. If locked, the controller will respond a "-" character.

Command Inputs Configuration and Safety

The commands in this group are used to choose which type of command the controller should respond to and enable safety features.

TABLE 24. Command Inputs Configuration and Safety

Command	Set Arguments	Get Argument	Description
ACS	Enable	None	Enable Ana Center Safety
AMS	Enable	None	Enable Ana Min/Max Safety
BRUN	Enable	None	MicroBasic Auto Start
CLIN	ChNbr Linearity	Channel	Command Linearity
CPRI	PriorityNbr PriorityLevel	PriorityLevel	Command Priority
DFC	ChNbr DefaultCommand	Channel	Default Command value
ECHOF	EchoOff	None	Disable/Enable RS232 & USB Echo
RWD	RS232 WdogTimeout	None	RS232 Watchdog (0 to disable)
TELS	Telemetry String	String	Telemetry Startup String

ACS - Analog Center Safety

This parameter enables the analog safety that requires that the input be at zero or centered before it can be considered as good. This safety is useful when operating with a joystick and requires that the joystick be centered at power up before motors can be made to run.

Syntax: **^ACS nn**
 ~ACS

Where: **nn** = 0 : safety disabled
 1 : safety enabled

Default Value: 1 = enabled

AMS - Analog within Min & Max Safety

This configuration is used to make sure that the analog input command is always within a user preset minimum and maximum safe value. It is useful to detect, for example, that the wire connection to a command potentiometer is broken. If the safety is enabled and the input is outside the safe range, the Analog input command will be considered invalid. The controller will then apply a motor command based on the priority logic. See "Command Priorities" on page 114.

Syntax: **^AMS nn**
 ~AMS

Where: **nn** = 0 : disabled
 1 : enabled

Default Value: 1 = enabled

BRUN - MicroBasic Auto Start

This parameter is used to enable or disable the automatic MicroBasic script execution when the controller powers up. When enabled, the controller checks that a valid script is present in Flash and will start its execution 2 seconds after the controller has become active.

The 2 seconds wait time can be circumvented by putting 2 in the command argument. However, this must be done only on scripts that are known to be bug-free. A crashing script will cause the controller to continuously reboot with little means to recover.

Syntax: **^BRUN nn**
 ~BRUN

Where: **nn** = 0 : disabled
 1 : enabled after 2 seconds
 2 : enabled immediately

Default Value: 0 = disabled

CLIN - Command Linearity

This parameter is used for applying an exponential or a logarithmic transformation on the command input, regardless of its source (serial, pulse or analog). There are 3 exponential

and 3 logarithmic choices. Exponential correction make the commands change less at the beginning and become stronger at the end of the command input range. The logarithmic correction will have a stronger effect near the start and lesser effect near the end. The linear selection causes no change to the input. A linearity transform is also available for all analog and pulse inputs. Both can be enabled although in most cases, it is best to use the Command Linearity parameter for modifying command profiles.

Syntax: **^CLIN cc nn**
 ~CLIN [cc]

Where: **cc** = Motor channel number
 nn = 0 : linear (no change)
 1 : exp weak
 2 : exp medium
 3 : exp strong
 4 : log weak
 5 : log medium
 6 : log strong

Default Value: All channels linear

Example: **^CLIN 1 1** = Sets linearity for channel 1 to exp weak

CPRI - Command Priorities

This parameter contains up to 3 variables (4 on controllers with Spektrum radio support) and is used to set which type of command in priority the controller will respond to and in which order. The first item is the first priority, second – second priority, third – third priority. Each priority item is then one of the three (four) command modes: Serial, Analog (Spektrum) or RC Pulse. See “Command Priorities” on page 114.

Syntax: **^CPRI pp nn**
 ~CPRI [pp]

Where: **pp** = priority rank 0, 1 or 2
 nn = 0 : disabled
 1 : Serial
 2 : RC
 3 : Analog

Default Value: priority 1 = RC
 priority 2 = RS232/USB
 priority 3 = Disabled

Examples: **^CPRI 1 2** = Set Serial as first priority
 ~CPRI 2 = Read what mode is second priority

DFC - Default Command value

The default command values are the command applied to the motor when no valid command is fed to the controller. It is the last priority item in the Command Priority mechanism. (See “Command Priorities” on page 114)

Syntax: **^DFC cc nn**
 ~DFC

Where: **cc** : Channel number
 nn : command value

Allowed Range: -1000 to +1000

Default Value: 0

Example: **^DFC 1 500** = Sets motor command to 500 when no command source are detected

ECHOF - Enable/Disable Serial Echo

This command is used to disable/enable the echo on the serial port. By default, the controller will echo everything that enters the serial communication port. By setting ECHOF to 1, commands are no longer being echoed. The controller will only reply to queries and the acknowledgements to commands can be seen.

Syntax: **^ECHOF nn**
 ~ECHOF

Where: **nn** = 0 : echo is enabled
 1 : echo is disabled

Default Value: 0 = enabled

Examples: **~ECHOF 1** = Disable echo

RWD - Serial Data Watchdog

This is the RS232/USB watchdog timeout parameter. It is used to detect when the controller is no longer receiving commands and switch to the next priority level. The watchdog value is a number in ms (1000 = 1s). The watchdog function can be disabled by setting this value to 0. The watchdog will only detect the loss of real-time commands that start with "!". All other traffic on the serial port will not refresh the watchdog timer. As soon as a valid command is received, motor operation will resume at whichever speed motors were running prior to the watchdog timeout.

Syntax: **^RWD nn**
 ~RWD

Where: **nn** = Timeout value in ms

Allowed Range: 0 to 65000

Default Value: 1000

Examples: **^RWD 1000** = Set watchdog to 1s
 ^RWD 0 = Disable watchdog

TELS - Telemetry String

This parameter command lets you enter the telemetry string that will be used when the controller starts up. The string is entered as a series of queries characters between a beginning and an ending quote. Queries must be separated by ":" colon characters. Upon the power up, the controller will load the query history buffer and it will automatically start

sending operating parameters based on the information in this string. Strings up to 48 characters long can be stored in this parameter.

Syntax: **^TELS "string"**
 ~TELS

Where: **string** = string of ASCII characters

Default Value: **""** (empty string)

Examples: **^TELS "?A:?V:?T:#200"** = Controller will issue Amps, Volts and temperature information automatically upon power up at 200ms intervals.

Digital Input/Output Configurations

These parameters configure the operating mode and how the inputs and outputs work.

TABLE 25. Digital Input/Output Configurations

Command	Set Arguments	Get Argument	Description
DINA	InputNbr Action	InputNbr	Digital Input Action
DINL	InputNbr Action	InputNbr	Digital Input Active Level
DOA	OutputNbr Action	InputNbr	Digital Output Action
DOL	OutputNbr Action	InputNbr	Digital Output Active Level

DINA - Digital Input Action

This parameter sets the action that is triggered when a given input pin is activated. The action list includes: limit switch for a selectable motor and direction, use as a deadman switch, emergency stop, safety stop or invert direction. Embedded in the parameter is the motor channel(s) to which the action should apply.

Syntax: **^DINA cc (aa + [mm])**
 ~DINA [cc]

Where: **cc** = Input channel number
 aa = 0 : no action
 1 : safety stop
 2 : emergency stop
 3 : motor stop
 4 : forward limit switch
 5 : reverse limit switch
 6 : invert direction
 7 : run MicroBasic script
 8 : load counter with home value
 mm = mot1*32 + mot2*64

Default Value: 0 = no action for each input

Example: **^DINA 1 33** = Input 1 as safety stop for Motor 1. I.e. 33 = 1 (safety stop) + 32 (Motor1)

DINL - Digital Input Active Level

This parameter is used to set the active level for each Digital input. An input can be made to be active high or active low. Active high means that pulling it to a voltage will trigger an action. Active low means pulling it to ground will trigger an action. This parameter is a single number for all inputs.

Syntax: **^DINL bb**
 ~DINL

Where: **bb** = $L1 + (L2 * 2) + (L3 * 4) + (L4 * 8) + (L5 * 16) + (L6 * 32) + \dots$
 and where: **Ln** = 0 : input is active high
 1 : input is active low

Default Value: All inputs active high

Example: **^DINL 33** = inputs 1 and 6 active low, all others active high. I.e. $33 = 1$
 (output1) + 32 (output6)

DOA - Digital Output Action

This configuration parameter will set what will trigger a given output pin. The parameter is a number in a list of possible triggers: when one or several motors are on, when one or several motors are reversed, when an Overvoltage condition is detected or when an Over-temperature condition is detected. Embedded in the parameter is the motor channel(s) to which the action should apply.

Syntax: **^DOA cc (aa + mm)**
 ~DOA [cc]

Where: **cc** = Output channel
 aa = 0 : no action
 1 : when motor on
 2 : motor reversed
 3 : overvoltage
 4 : overtemperature
 5 : mirror status LED
 6 : no MOSFET failure
 mm = $\text{mot1} * 16 + \text{mot2} * 32$

Default Value: All outputs disabled

Example: **^DOA 1 33**

DOL - Digital Outputs Active Level

This parameter configures whether an output should be set to ON or to OFF when it is triggered.

Syntax: **^DOL bb**
 ~DOL

Where: **bb** = $L1 + (L2 * 2) + (L3 * 4) + (L4 * 8) + (L5 * 16) + (L6 * 32) + \dots$
 and where: **Ln** = 0 : input is active high
 1 : input is active low

Default Value: 0 : All outputs active high

Example: **^DOL 9** = All outputs switch on when activated except outputs 1 and 4 which switch off when activated. I.e. 9 = 1 (ouput1) + 8 (output4)

Analog Input Configurations

This section covers the various configuration parameter applying to the analog inputs.

TABLE 26. Analog Input Configurations

Command	Set Arguments	Get Argument	Description
ACTR	InputNbr Center	InputNbr	Analog Center
ADB	InputNbr Deadband	InputNbr	Analog Deadband
AINA	InputNbr Action	InputNbr	Analog Input Actions
ALIN	InputNbr Linearity	InputNbr	Analog Linearity
AMAX	InputNbr Max	InputNbr	Analog Max
AMAXA	InputNbr Action	InputNbr	Action on Analog Input Max
AMIN	InputNbr Min	InputNbr	Analog Min
AMINA	InputNbr Action	InputNbr	Action on Analog Input Min
AMOD	InputNbr Mode	InputNbr	Analog Input Mode
APOL	InputNbr Polarity	InputNbr	Analog Input Polarity

ACTR - Set Analog Input Center (0) Level

This parameter is the measured voltage on input that will be considered as the center or the 0 value. The min, max and center are useful to set the range of a joystick or of a feedback sensor. Internally to the controller, commands and feedback values are converted to -1000, 0, +1000.

Syntax: **^ACTR cc nn**
~ACTR [cc]

Where: **nn** = 0 to 5000mV

Default Value: 2500mV

Example: **^ACTR 3 2000** = Set Analog Input 3 Center to 2000mV

ADB - Analog Deadband

This parameter selects the range of movement change near the center that should be considered as a 0 command. This value is a percentage from 0 to 50% and is useful to allow some movement of a joystick around its center position before any power is applied to a motor.

Syntax: **^ADB cc nn**
~ADB [cc]

Where: **cc** = Analog channel number
nn = Deadband in %

Allowed Range: 0 to 50%

Default Value: 5% on all inputs

Example: **^ADB 6 10** = Sets Deadband for channel 6 at 10%

AINA - Analog Input Usage

This parameter selects whether an input should be used as a command feedback or left unused. When selecting command or feedback, it is also possible to select which channel this command or feedback should act on. Feedback can be position feedback if potentiometer is used or speed feedback if tachometer is used. Embedded in the parameter is the motor channel to which the command or feedback should apply.

Syntax: **^AINA cc (nn + mm)**
~AINA [cc]

Where: **cc** = Input channel number
nn = 0 : unused
1 : command
2 : feedback
mm = mot1*16 + mot2*32

Default Value: All channels unused

Example: **^AINA 1 17** = Sets Analog channel 1 as command for motor 1. I.e. 17 = 1 (command) +16 (motor 1)

ALIN - Analog Linearity

This parameter is used for applying an exponential or a logarithmic transformation on an analog input. There are 3 exponential and 3 logarithmic choices. Exponential correction will make the commands change less at the beginning and become stronger at the end of the joystick movement. The logarithmic correction will have a stronger effect near the start and lesser effect near the end. The linear selection causes no change to the input.

Syntax: **^ALIN cc nn**
~ALIN [cc]

Where: **cc** = Input channel number
nn = 0 : linear (no change)
1 : exp weak
2 : exp medium
3 : exp strong
4 : log weak
5 : log medium
6 : log strong

Default Value: All channels linear

Example: **^ALIN 1 1** = Sets linearity for channel 1 to exp weak

AMAX - Set Analog Input Max Range

This parameter sets the voltage that will be considered as the maximum command value. The min, max and center are useful to set the range of a joystick or of a feedback sensor. Internally to the controller, commands and feedback values are converted to -1000, 0, +1000.

Syntax: **^AMAX cc nn**
 ~AMAX [cc]

Where: **nn** = 0 to 5000mV

Default Value: 4900mV

Example: **^AMAX 4 4500** = Set Analog Input 4 Max range to 4500mV

AMAXA - Action at Analog Max

This parameter selects what action should be taken if the maximum value that is defined in AMAX is reached. The list of action is the same as these of the DINA (see "DINA" on page 199). For example, this feature can be used to create "soft" limit switches, in which case the motor can be made to stop if the feedback sensor in a position mode has reached a maximum value.

Syntax: **^AMAXA cc (aa + mm)**
 ~AMAXA [cc]

Where: **cc** = Input channel number
 aa = DIN Action List
 mm = mot1 * 16 + mot2 * 32

Default Value: No action on all channels

Example: **^AMAXA 3 34** = Stops motor 2

AMIN - Set Analog Input Min Range

This parameter sets the raw value on the input that will be considered as the minimum command value. The min, max and center are useful to set the range of a joystick or of a feedback sensor. Internally to the controller, commands and feedback values are converted to -1000, 0, +1000.

Syntax: **^AMIN cc nn**
 ~AMIN [cc]

Where: **nn** = 0 to 5000mV

Default Value: 100mV

Example: **^AMIN 5 250** = Set Analog Input 5 Min to 250mV

AMINA - Action at Analog Min

This parameter selects what action should be taken if the minimum value that is defined in AMIN is reached. The list of action is the same as these of the DINA (see "DINA" on page 199). For example, this feature can be used to create "soft" limit switches, in which case the motor can be made to stop if the feedback sensor in a position mode has reached a minimum value.

Syntax: **^AMINA cc (aa + mm)**
 ~AMINA [cc]

Where: **cc** = Input channel number
 aa = DIN Action list
 mm = mot1 * 16 + mot2 * 32

Default Value: No action on all channels

Example: **^AMINA 2 33** = Stops motor 2. I.e. 33 = 1 (motor stop) + 32 (motor2)

AMOD - Enable and Set Analog Input Mode

This parameter is used to enable/disable an analog input pin. When enabled, it can be made to measure an absolute voltage from 0 to 5V, or a relative voltage that takes the 5V output on the connector as the 5V reference. The absolute mode is preferred whenever measuring a voltage generated by an outside device or sensor. The relative mode is the mode to use when a sensor or a potentiometer is powered using the controller's 5V output of the controller. Using the relative mode gives a correct sensor reading even though the 5V output is imprecise.

Syntax: **^AMOD cc nn**
 ~AMOD [cc]

Where: **cc** = channel number
 nn = 0 : disabled
 1 : absolute
 2 : relative

Example: **^AMOD 1 1** = Analog input 1 enabled in absolute mode

APOL - Analog Input Polarity

Inverts the analog capture polarity value after conversion. When this configuration bit is cleared, the pulse capture is converted into a -1000 to +1000 command or feedback value. When set, the converted range is inverted to +1000 to -1000.

Syntax: **^APOL cc nn**
 ~APOL

Where: **cc** = analog channel number
 nn = 0: not inverted
 1: inverted

Pulse Input Configuration

These configuration commands are used to define the operating mode for the pulse inputs.

TABLE 27. Pulse Input Configuration

Command	Set Arguments	Get Argument	Description
PCTR	InputNbr Center	InputNbr	Pulse Center
PDB	InputNbr Deadband	InputNbr	Pulse Deadband
PINA	InputNbr Action	InputNbr	Pulse Input Actions
PLIN	InputNbr Linearity	InputNbr	Pulse Linearity
PMAX	InputNbr Max	InputNbr	Pulse Max
PMAXA	InputNbr Action	InputNbr	Action on Pulse Input Max
PMIN	InputNbr Min	InputNbr	Pulse Min
PMINA	InputNbr Action	InputNbr	Action on Pulse Input Min
PMOD	InputNbr Mode	InputNbr	Pulse Input Mode
PPOL	InputNbr Polarity	InputNbr	Pulse Input Polarity

PCTR - Pulse Center Range

This defines the raw value of the measured pulse that would be considered as the 0 value inside the controller. The default value is 1500 which is the center position of the pulse in the RC radio mode.

Syntax: **^PCTR cc nn**
 ~PCTR [cc]

Where: **nn** = 0 to 65000 μ s

Default Value: 1500 μ s

PDB - Pulse Input Deadband

This sets the deadband value for the pulse capture. It is defined as the percent number from 0 to 50% and defines the amount of movement from joystick or sensor around the center position before its converted value begins to change.

Syntax: **^PDB cc nn**
 ~PDB [cc]

Where: **cc** = Pulse channel number
 nn = Deadband in %

Allowed Range: 0 to 50%

Default Value: 0%

PINA - Pulse Input Use

This parameter selects whether an input should be used as a command feedback, position feedback or left unused. Embedded in the parameter is the motor channel that this command or feedback should act on. Feedback can be position feedback if potentiometer is used or speed feedback if tachometer is used.

Syntax: **^PINA cc (nn + mm)**
 ~PINA [cc]

Where: **cc** = Input channel number
 nn = 0 : unused
 1 : command
 2 : feedback
 mm = mot1*16 + mot2*32

Default Value: All channels unused

Example: **^PINA 1 17** = Sets Pulse channel 1 as command for motor 1

PLIN - Pulse Linearity

This parameter is used for applying an exponential or a logarithmic transformation on a pulse input. There are 3 exponential and 3 logarithmic choices. Exponential correction will make the commands change less at the beginning and become stronger at the end of the joystick movement. The logarithmic correction will have a stronger effect near the start and lesser effect near the end. The linear selection causes no change to the input.

Syntax: **^PLIN cc nn**
 ~PLIN [cc]

Where: **cc** = Input channel number
 nn = 0 : linear (no change)
 1 : exp weak
 2 : exp medium
 3 : exp strong
 4 : log weak
 5 : log medium
 6 : log strong

Default Value: All channels linear

PMAX - Pulse Max Range

This parameter defines the raw pulse measurement number that would be considered as the +1000 internal value to the controller. By default, it is set to 2000 which is the max pulse width of an RC radio pulse.

Syntax: **^PMAX cc nn**
 ~PMAX [cc]

Where: **nn** = 0 to 65000 μ s

Default Value: 2000 μ s

PMAXA - Action at Pulse Max

This parameter configures the action to take when the max value that is defined in PMAX is reached. The list of action is the same as in the DINA digital input action list. Embedded in the parameter is the motor channel(s) to which the action should apply.

Syntax: **^PMAXA cc (aa + mm)**
 ~PMAXA [cc]

Where: **cc** = Input channel number
 aa = DIN Action List
 mm = mot1*16 + mot2*32

Default Value: No action on all channels

PMIN - Pulse Min Range

This sets the raw value of the pulse capture that would be considered as the -1000 internal value to the controller. The value is in number of microseconds (1000 = 1ms). Maximum captured value is 65000. The default value is 1000 microseconds which is the minimum value on an RC radio pulse.

Syntax: **^PMIN cc nn**
 ~PMIN [cc]

Where: **nn** = 0 to 65000 μ s

Default Value: 1000 μ s

PMINA - Action at Pulse Min

This parameter selects what action should be taken if the minimum value that is defined in PMIN is reached. The list of action is the same as these of the DINA digital input actions (see "DINA" on page 199). Embedded in the parameter is the motor channel(s) to which the action should apply.

Syntax: **^PMINA cc (aa + mm)**
 ~PMINA [cc]

Where: **cc** = Input channel number
 aa = DIN Action List
 mm = mot1*16 + mot2*32

Default Value: No action on all channels

PMOD - Pulse Mode Select

This parameter is used to enable/disable the pulse input and select its operating mode, which can be: pulse with measurement, frequency or duty cycle. Inputs can be measured with a high precision over a large range of time or frequency. An input will be processed and converted to a command or a feedback value in the range of -1000 to +1000 for use by the controller internally.

Syntax: **^PMOD cc nn**
 ~PMOD [cc]

Where: **nn** = 0 : Disabled
 1 : Pulse width
 2 : Frequency
 3 : Period

PPOL - Pulse Input Polarity

Inverts the pulse capture value after conversion. When this configuration bit is cleared, the pulse capture is converted into a -1000 to +1000 command or feedback value. When set, the converted range is inverted to +1000 to -1000.

Syntax: **^PPOL cc nn**
~PPOL

Where: **cc** = pulse channel number
nn = 0: not inverted
 1: inverted

Encoder Operations

The following parameters are used to configure encoder and functions that are enabled by the encoders.

TABLE 28. Encoder Operation

Command	Set Arguments	Get Argument	Description
EHL	Channel EncHighLimit	Channel	Encoder High Limit
EHLA	Channel EncHiLimAction	Channel	Encoder High Limit Action
EHOME	Channel HomeCount	Channel	Encoder Counter Load at Home Position
ELL	Channel EncLowLimit	Channel	Encoder Low Limit
ELLA	Channel EncLoLimAction	Channel	Encoder Low Limit Action
EMOD	Channel EncoderUse	Channel	Encoder Use
EPPR	Channel EncoderPPR	Channel	Encoder PPR

EHL - Encoder High Count Limit

This parameter is the same as the ELL except that it defines an upper count boundary at which to trigger the action. This value, together with the Low Count Limit, are also used in the position mode to determine the travel range when commanding the controller with a relative position command. In this case, the Low Limit Count is the desired position when a command of -000 is received

Syntax: **^EHL cc nn**
~EHL

Where: **cc** : Channel number
nn = Counter value

Default Value: + 20000

EHLA - Encoder High Limit Action

This parameter lets you select what kind of action should be taken when the upper boundary of the counter is reached. The list of action is the same as in the DINA digital input action list (see "DINA" on page 199).

Syntax: **^EHLA cc nn**
 ~EHLA [cc]

Where: **cc** = Input channel number
 aa = DIN Action List
 mm = $\text{mot1} * 16 + \text{mot2} * 32$

Default Value: 0 = no action for each encoder

EHOME - Encoder Counter Load at Home Position

This parameter contains a value that will be loaded in the selected encoder counter when a home switch is detected, or when a Home command is received from the serial/USB, or issued from a MicroBasic script.

Syntax: **^EHOME cc nn**
 ~EHOME

Where: **cc**: channel number
 nn = counter value to be loaded

Default Value: 0

ELL - Encoder Low Count Limit

This parameter allows you to define a minimum count value at which the controller will trigger an action when the counter dips below that number. This feature is useful for setting up virtual or "soft" limit switches. This value, together with the High Count Limit, are also used in the position mode to determine the travel range when commanding the controller with a relative position command. In this case, the Low Limit Count is the desired position when a command of -1000 is received.

Syntax: **^ELL cc nn**
 ~ELL

Where: **cc** : Channel number
 nn = Counter value

Default Value: - 20000

Example: **^ELL 1-100000** = Set encoder 1 low limit

ELLA - Encoder Low Limit Action

This parameter lets you select what kind of action should be taken when the low limit count is reached on the encoder. The list of action is the same as in the DINA digital input action list (see "DINA" on page 199). Embedded in the parameter is the motor channel(s) to which the action should apply.

Syntax: **^ELLA cc (aa + mm)**
 ~ELLA [cc]

Where: **cc** = Input channel number
 aa = DIN Action List
 mm = mot1 * 16 + mot2 * 32

Default Value: 0 = no action for each encoder

EMOD - Encoder Usage

This parameter defines what use the encoder is for. The encoder can be used to set command or to provide feedback (speed or position feedback). The use of encoder as feedback devices is the most common. Embedded in the parameter is the motor to which the encoder is associated.

Syntax: **^EMOD cc (aa + mm)**
 ~EMOD [cc]

Where: **cc** : Channel number
 aa = 0 : Unused
 1 : Command
 2 : Feedback
 mm = mot1 * 16 + mot2 * 32

Example: **^EMOD 1 18** = Encoder used as feedback for channel 1

EPPR - Encoder PPR Value

This parameter will set the pulse per revolution of the encoder that is attached to the controller. The PPR is the number of pulses that is issued by the encoder when making a full turn. For each pulse there will be 4 counts which means that the total number of a counter increments inside the controller will be 4x the PPR value. Make sure not to confuse the Pulse Per Revolution and the Count Per Revolution when setting up this parameter.

Syntax: **^EPPR cc nn**
 ~EPPR

Where: cc : Channel number
 nn : PPR value

Allowed Range: 1 to 5000

Default Value: 100

Example: **^EPPR 2 200** = Sets PPR for encoder 2 to 200

Brushless Specific Commands

TABLE 29. Brushless Specific Commands

Command	Set Arguments	Get Argument	Description
BHL	BLHighLimit	none	BL Counter High Limit
BHLA	BLHiLimAction	none	BL Counter High Limit Action
BHOME	BLHomeCount	none	BL Counter Load at Home Position
BLFB	BLFeedback	none	Encoder or Hall Sensor Feedback
BLL	BLLowLimit	none	BL Counter Low Limit
BLLA	BLLoLimAction	none	BL Counter Low Limit Action
BLSTD	StallDetection	none	BL Stall Detection
BPOL	NumberOfPoles	none	Number of Poles of BL Motor

BHL - Brushless Counter High Limit

This parameter allows you to define a minimum brushless count value at which the controller will trigger an action when the counter rises above that number. This feature is useful for setting up virtual or “soft” limit switches. This value, together with the Low Count Limit, are also used in the position mode to determine the travel range when commanding the controller with a relative position command. In this case, the Low Limit Count is the desired position when a command of 1000 is received

Syntax: **^BHL nn**
 ~BHL

Where: **nn** = Counter value

Default Value: -2000

Example: **^BHL 10000** = Set brushless counter high limit

BHLA - Brushless Counter High Limit Action

This parameter lets you select what kind of action should be taken when the upper boundary of the brushless counter is reached. The list of action is the same as in the DINA digital input action list (See “DINA” on page 199).

Syntax: **^BHLA nn**
 ~BHLA [cc]

Where: **aa** = DIN Action List

Default Value: 0 = no action

BHOME - Brushless Counter Load at Home Position

This parameter contains a value that will be loaded in the brushless hall sensor counter when a home switch is detected, or when a Home command is received from the serial/USB, or issued from a MicroBasic script.

Syntax: **^BHOME nn**
 ~BHOME

Where: **nn** = counter value to be loaded

Default Value: 0

BLFB - Encoder or Hall Sensor Feedback

On brushless motors system equipped with optical encoders, this parameter lets you select the encoder or the brushless hall sensors as the source of speed or position feedback. Encoders provide higher precision capture and should be preferred whenever possible.

Syntax: **^BLFB nn**
 ~BLFB

Where: **nn** = 0: hall sensors feedback
 1: encoder feedback

Default Value: 0 hall sensor

BLL - Brushless Counter Low Limit

This parameter allows you to define a minimum brushless count value at which the controller will trigger an action when the counter dips below that number. This feature is useful for setting up virtual or "soft" limit switches. This value, together with the High Count Limit, are also used in the position mode to determine the travel range when commanding the controller with a relative position command. In this case, the Low Limit Count is the desired position when a command of -1000 is received

Syntax: **^BLL nn**
 ~BLL

Where: **nn** = Counter value

Default Value: - 2000

Example: **^BLL -10000** = Set brushless counter low limit

BLLA - Brushless Counter Low Limit Action

This parameter lets you select what kind of action should be taken when the low limit count is reached on the hall sensor counter of brushless motors. The list of action is the same as in the DINA digital input action list (See "DINA" on page 199) Embedded in the parameter is the motor channel(s) to which the action should apply.

Syntax: **^BLLA nn**
 ~BLLA

Where: **aa** = DIN Action List

Default Value: 0 = no action

BLSTD - Brushless Stall Detection

This parameter controls the stall detection of brushless motors. If no motion is sensed (i.e. counter remains unchanged) for a preset amount of time while the power applied is above a given threshold, a stall condition is detected and the power to the motor is cut until the command is returned to 0. This parameter allows three combination of time & power sensitivities.

Syntax: **^BLSTD nn**
 ~BLSTD

Where: **nn** = 0 : Disabled
 1 : 250ms at 10% Power
 2 : 500ms at 25% Power
 3 : 1000ms at 50% Power

Default Value: 2

Example: **^BLSTD 2**: Motor will stop if applied power is higher than 10% and no motion is detected for more than 250ms

BPOL - Number of Poles of Brushless Motor and Speed Polarity

This parameter is used to define the number of poles of the brushless motor connected to the controller. This value is used to convert the hall sensor transition counts into actual RPM and number of motor turns. Entering a negative number will invert the measured speed polarity.

Syntax: **^BPOL nn**
 ~BPOL

Where: **nn** = Number of poles

Default Value: 2

General Power Stage Configuration Commands

This section describes all the configuration parameters that relate to the controller's power stage and that are common to both outputs in multi-channel controllers.

TABLE 30. General Power Stage Configuration Commands

Command	Parameter	Description
BKD	Delay	Brake Activation Delay
MXMD	Mode Number	Mixed Mode
OVL	Voltage	Overvoltage Limit
PWMF	Frequency	PWM Frequency
THLD	Level	Short Circuit detection threshold
UVL	Voltage	Undervoltage Limit

BKD - Brake Activation Delay

Set the delay from the time a motor stops and the time an output connected to a brake solenoid will be released.

Syntax: **^BKD nn**
 ~BKD

Where: **nn** = delay in milliseconds

MXMD - Separate or Mixed Mode Select

This configuration parameter selects the mixed mode operation. It is applicable to dual channel controllers and serves to operate the two channels in mixed mode for tank-like steering. There are 3 possible values for this parameter for selecting separate or one of the two possible mixed mode algorithms.

Syntax: **^MXMD nn**
 ~MXMD

Where: **nn** = 0 : Separate
 1 : Mode 1
 2 : Mode 2

Default Value: 0 = separate

Example: **^MXMD 0** = Set mode to separate

OVL - Overvoltage Limit

Overvoltage. This number sets the voltage level at which the controller must turn off its power stage and signal an Overvoltage condition. The number that can be entered is the value in volts multiplied by 10 (e.g. 450 = 45.0V)

Syntax: **^OVL nn**
 ~OVL

Where: **nn** = Volt *10

Allowed Range: 10.0V to Max Voltage rated in controller Data Sheet

Default Value: Maximum voltage rated in controller Data Sheet

Example: **^OVL 400** = Set Overvoltage limit to 40.0V

PWMF - PWM Frequency

This parameter sets the PWM frequency of the switching output stage. It can be set from 1 kHz to 32 kHz. The frequency is entered as kHz value multiplied by 10 (e.g. 185 = 18.5 kHz). Beware that a too low frequency will create audible noise and would result in lower performance operation.

Syntax: **^PWMF nn**
~PWMF

Where: **nn** = Frequency * 10

Allowed Range: 10 to 200 (1kHz to 20kHz)

Default Value: 180 = 18.0 kHz

Example: **^PWMF 200** = Set PWM frequency to 20kHz

THLD - Short Circuit Detection Threshold

This configuration parameter sets the threshold level for the short circuit detection. There are 4 sensitivity levels from 0 to 3.

Syntax: **^THLD nn**
~THLD

Where: **nn** = 0 : Very high sensitivity
1 : Medium sensitivity
2 : Low sensitivity
3 : Short circuit protection disabled

Default Value: 1 = Medium sensitivity

Example: **^THLD 1** = Set short circuit detection sensitivity to medium.

Notes: You should never disable the short circuit protection.

UVL - Undervoltage Limit

This parameter sets the voltage below which the controller will turn off its power stage. The voltage is entered as a desired voltage value multiplied by 10.

Syntax: **^UVL nn**
~UVL

Where: **nn** = Volt * 10

Allowed Range: 5.0V to Max Voltage rated in controller Data Sheet

Default Value: 50 = 5.0V

Example: **^UVL 100** = Set undervoltage limit to 10.0 V

Motor Channel Configuration and Set Points

This section covers all motor operating parameters mostly related to controller's power stage.

TABLE 31. Motor Channel Configuration and Set Points

Command	Set Arguments	Get Argument	Description
ALIM	Channel AmpLimit	Channel	Motor Amps Limit
ATGA	Channel AmpTrigger Action	Channel	Amps Trigger Action
ATGD	Channel AmpTrigger Delay	Channel	Amps Trigger Delay
ATRIG	Channel AmpTrigger	Channel	Amps Trigger Value
CLERD	Channel LoopErrorDetection	Channel	Close Loop Error Detection
ICAP	Channel Capped Int	Channel	PID Integral Cap
KD	Channel DiffGain	Channel	PID Differential Gain
KI	Channel IntGain	Channel	PID Integral Gain
KP	Channel PropGain	Channel	PID Proportional Gain
MAC	Channel Acceleration	Channel	Motor Acceleration
MDEC	Channel Deceleration	Channel	Motor Deceleration
MMOD	Channel OperatingMode	Channel	Motor Operating Mode
MVEL	Channel DefPositionVel	Channel	Motor(s) Default Position Velocity
MXPF	Channel MaxPower	Channel	Motor Max Power Forward
MXPR	Channel MaxPower	Channel	Motor Max Power Reverse
MXRPM	Channel MaxRPM	Channel	Motor RPM at 100%
MXTRN	Channel MaxTurns	Channel	Number of Motor Turns between Limits

ALIM - Amp Limit

This is the maximum Amps that the controller will be allowed to deliver to a motor regardless the load of that motor. The value is entered in Amps multiplied by 10. The value is the Amps that are measured at the motor and not the Amps measured from a battery. When the motor draws current that is above that limit, the controller will automatically reduce the output power until the current drops below that limit.

Syntax: **^ALIM cc nn**
~ALIM [cc]

Where: **cc** = Motor channel
nn = Amps * 10

Allowed Range: 10A to Max Amps rating in Product Datasheet

Default Value: 75% of Max Datasheet rating

Example: **^ALIM 1 455** = Set Amp limit for Motor 1 to 45.5A

ATGA - Amps Trigger Action

This parameter sets what action to take when the Amps trigger is activated. The list is the same as in the DINA digital input actions (see "DINA" on page 199). Typical use for that feature is as a limit switch when, for example, a motor reaches an end and enters stall condition, the current will rise, and that current increase can be detected and the motor be made to stop until the direction is reversed. Embedded in the parameter is the motor channel(s) to which the action should apply.

Syntax: **^ATGA cc (aa + mm)**
 ~ATGA [cc]

Where: **cc** = Input channel number
 aa = DIN Action List
 mm = mot1*16 + mot2*32

Default Value: No action on all motor channels

ATGD - Amps Trigger Delay

This parameter contains the time during which the Amps Trigger Level (ATRIG) must be exceeded before the Amps Trigger Action (ATGA) is called. This parameter is used to prevent Amps Trigger Actions to be taken in case of short duration spikes.

Syntax: **^ATGD cc nn**
 ~ATGD [cc]

Where: **cc**: channel number
 nn = delay value in milliseconds

Example: **^ATGD 1 1000** = Action that is define with ATRIGA will be triggered if motor Amps limit exceeds the value set with ATGL for more than 1000ms

ATRIG - Amps Trigger Level

This parameter lets you select Amps threshold value that will trigger an action. This threshold must be set to be below the ALIM Amps limit. When that threshold is reached, then list of action can be selected using the ATGA parameter.

Syntax: **^ATRIG cc nn**
 ~ATRIG [cc]

Where: **cc** = Motor channel
 nn = Amps *10

Default Value: 75% of Max Datasheet rating

Examples: **^ATRIG 2 550** = Set Amps Trigger to 55.0A

CLERD - Closed Loop Error Detection

This parameter is used to detect large tracking errors due to mechanical or sensor failures, and shut down the motor in case of problem in closed loop speed or position system. The detection mechanism looks for the size of the tracking error and the duration the error is present. This parameter allows three combination of time & error level.

Syntax: **^CLERD cc nn**
 ~CLERS

Where: **cc** = channel
 nn = 0 : Detection disabled
 1 : 250ms at Error > 100
 2 : 500ms at Error > 250
 3 : 1000ms at Error > 500

Default Value: 2

Example: **^CLERD 2** = Motor will stop if command - feedback is greater than 100 for more than 250ms

ICAP - PID Integral Cap

This parameter is the integral cap as a percentage. This parameter will limit maximum level of the Integral factor in the PID. It is particularly useful in position systems with long travel movement, and where the integral factor would otherwise become very large because of the extended time the integral would allow to accumulate. This parameter can be used to dampen the effect of the integral parameter without reducing the gain.

Syntax: **^ICAP cc nn**
 ~ICAP [cc]

Where: **cc** = Motor channel
 nn = Integral cap in %

Allowed Range: 1% to 100%

Default Value: 100%

KD - PID Differential Gain

This is the Differential Gain for that channel. The value is set as the gain multiplied by 10.

Syntax: **^KD cc nn**
 ~KD

Where: **cc** = Motor channel
 nn = Gain * 10

Allowed Range: 0 to 250 (2.50)

Default Value: 200 (2.0)

Example: **^KD 1 155** = Set motor channel 1 Differential Gain to 15.5

KI - PID Integral Gain

This parameter sets the Integral Gain of the PID for that channel. The value is set as the gain multiplied by 10.

Syntax: **^KI cc nn**
 ~KI

Where: **cc** = Motor channel
 nn = Gain * 10

Allowed Range: 0 to 250 (2.50)

Default Value: 200 (2.0)

Example: **^KI 1 155** = Set motor channel 1 Integral Gain to 15.5

KP - PID Proportional Gain

This parameter sets the Proportional Gain for that channel. The value is entered as the gain multiplied by 10.

Syntax: **^KP cc nn**
 ~KP

Where: **cc** = Motor channel
 nn = Gain * 10

Allowed Range: 0 to 250 (2.50)

Default Value: 200 (2.0)

Example: **^KP 1 155** = Set motor channel 1 Proportional Gain to 15.5

MAC - Motor Acceleration Rate

Set the rate of speed change during acceleration for a motor channel. This command is identical to the AC realtime command. Acceleration value is in 0.1 * RPM per second. When using controllers fitted with encoder, the speed and acceleration value are actual RPMs. Brushless motor controllers use the hall sensor for measuring actual speed and acceleration will also be in actual RPM/s.

When using the controller without speed sensor, the acceleration value is relative to the Max RPM configuration parameter, which itself is a user-provide number for the speed normally expected speed at full power. Assuming that the Max RPM parameter is set to 1000, and acceleration value of 10000 means that the motor will go from 0 to full speed in exactly 1 second, regardless of the actual motor speed.

Syntax: **^MAC cc nn**
 ~MAC [cc]

Where: **cc** = Motor channel
 nn = Acceleration time in 0.1 RPM per seconds

Allowed Range: 100 to 32000

MDEC - Motor Deceleration Rate

This parameter sets the motor deceleration. It is the same as MACC but for when the motor goes from a high speed to a lower speed.

Syntax: **^MDEC cc nn**
 ~MDEC [cc]

Where: **cc** = Motor channel
 nn = Deceleration time in 0.1 RPM per second

Allowed Range: 100 to 32000

MMOD - Operating Mode

This parameter lets you select the operating mode for that channel.

Syntax: **^MMOD cc nn**
 ~MMOD [cc]

Where: **cc** = motor channel
 nn = 0 : open-loop speed
 1 : closed-loop speed
 2 : closed-loop position relative
 3 : closed-loop count position
 4 : closed-loop position tracking
 5 : torque

Default Value: All motors in open-loop speed mode

Examples: **^MMOD 2**

MVEL - Default Position Velocity

This parameter is the default speed at which the motor moves while in position mode. Values are in RPMs. To change velocity while the controller is in operation, use the !S runtime command.

Syntax: **^MVEL [cc] nn**
 ~MVEL [cc]

Where: **cc** = Motor Channel. May be omitted in single channel controllers
 nn = Velocity value in RPM

MXPF - Motor Max Power Forward

This parameter lets you select the scaling factor for the power output, in the forward direction, as a percentage value. This feature is used to connect motors with voltage rating that is less than the battery voltage. For example, using a factor of 50% it is possible to connect a 12V motor onto a 24V system, in which case the motor will never see more than 12V at its input even when the maximum power is applied.

Syntax: **^MXPF cc nn**
 ~MXPF [cc]

Where: **cc** = Motor channel
 nn = power scaling

Allowed Range: 25% to 100%

Default Value: 100%

Example: **^MXPF 2 50** = Scale output power by 50%

MXPR - Motor Max Power Reverse

This parameter is the same as the MXPF Motor Max Power Forward but applied when the motor is moving in the reverse direction

Syntax: **^MXPR cc nn**
~MXPR [cc]

Where: **cc** = Motor channel
nn = power scaling

Allowed Range: 25% to 100%

Default Value: 100%

MXRPM - Max RPM Value

This parameter lets you select which speed value would be considered as +1000 as the internal relative speed parameter. The controller can measure speed in absolute RPM values. However for internal use in some modes, controller uses a speed value relative to a user defined max RPM value. The MXRPM value lets you select what that max level will be.

Syntax: **^MXRPM cc nn**
~MXRPM [cc]

Where: **cc** = Channel number
nn = Max RPM value

Allowed Range: 10 to 65000

Default Value: 3000

Notes: The relative speed can be read using the **?sr** query

MXTRN - Turns between Limits

This parameter is used in position mode to measure the speed when an analog or pulse feedback sensor is used. The value is the number of motor turns between the feedback value of -1000 and +1000. When encoders are used for feedback, this parameter is automatically computed from the encoder configuration, and can thus be omitted. See "Closed Loop Relative and Tracking Position Modes" on page 93 for a detailed discussion.

Syntax: **^MXTRN cc nn**
~MXTRN [cc]

Where: **cc** = Motor channel
nn = Number of turns x 10

Allowed Range: 10 to 100000

Default Value: 1000

Example: **^MXTRN 1 2000** = Set max turns for motor 1 to 200.0 turns

Sepex Specific Commands

TABLE 32.

Command	Set Arguments	Get Argument	Description
SXC	CurvePoint Value	Point	Sepex Curve Points
SXM	MinimumCurrent	none	Minimum Field Current

SXC - Sepex Motor Excitation Table

This parameter is used on Sepex controllers to generate the field excitation power based on the power level that is currently applied to the armature channel. There are 5 values in this parameter for 0%, 25%, 50%, 75%, and 100%. When running, depending on the power level that is applied on the armature, the power level on the excitation will be interpolated from that table.

Syntax: **^SXC pp nn**
~SXC [pp]

Where: **pp** = point 1 to 5 in table
nn = power level in %

Allowed Range: 0 to 100%

Example: **^SXC 1 50**
^SXC 2 62
^SXC 3 75
^SXC 4 87
^SXC 5 100
Loads table with 50%, 62%, 75%, 87%, 100%.

SXM - Sepex Minimum Excitation Current

This parameter sets the minimum current that must be measured in the field output for the armature channel to be enabled. This is a safety feature to make sure that there is no current flowing into the armature unless an excitation current is being detected. Outputting current into the armature without excitation will cause serious damage without this protection.

Syntax: **^SXM nn**
~SXM

Where: **nn** = current in Amps *10

Allowed Range: 10 (1.0A) to 250 (25.0A)

CAN Specific Commands

CTPS - CANOpen TPDO Send Rate

Sets the send rate for each of the 4 TPDOs when CANOpen is enabled.

Syntax: **^CTPS nn mm**

Where: **nn** = TPDO number, 1 to 4
 mm = rate in ms

Notes: If **mm** = 0, the TPDO is not transmitted

SECTION 17

Using the Roborun Configuration Utility

A PC-based Configuration Utility is available, free of charge, from Roboteq. This program makes configuring and operating the controller much more intuitive by using pull-down menus, buttons and sliders. The utility can also be used to update the controller's software in the field as described in "Updating the Controller's Firmware" on page 241.

System Requirements

To run the utility, the following is needed:

- PC compatible computer running Windows 98, ME, 2000, XP, Vista or Windows7
- A USB connector for controllers with USB connectivity
- An unused serial communication port on the computer with a 9-pin, female connector for controllers using RS232 communication
- An Internet connection for downloading the latest version of the Roborun Utility or the Controller's Software
- 5 Megabytes of free disk space

If the PC is not equipped with an RS232 serial port, one may be added using a USB to RS232 converter.

Downloading and Installing the Utility

The Configuration Utility must be obtained from the Support page on Roboteq's web site at www.roboteq.com.

- Download the program and run the file setup.exe inside the Roborun Setup folder
- Follow the instructions displayed on the screen

- After the installation is complete, run the program from your Start Menu > Programs > Roboteq

The controller does not need to be connected to the PC to start the Utility.

The Roborun+ Interface

The Roborun+ utility is provided as a tool for easily configuring the Roboteq controller and running it for testing and troubleshooting purposes.

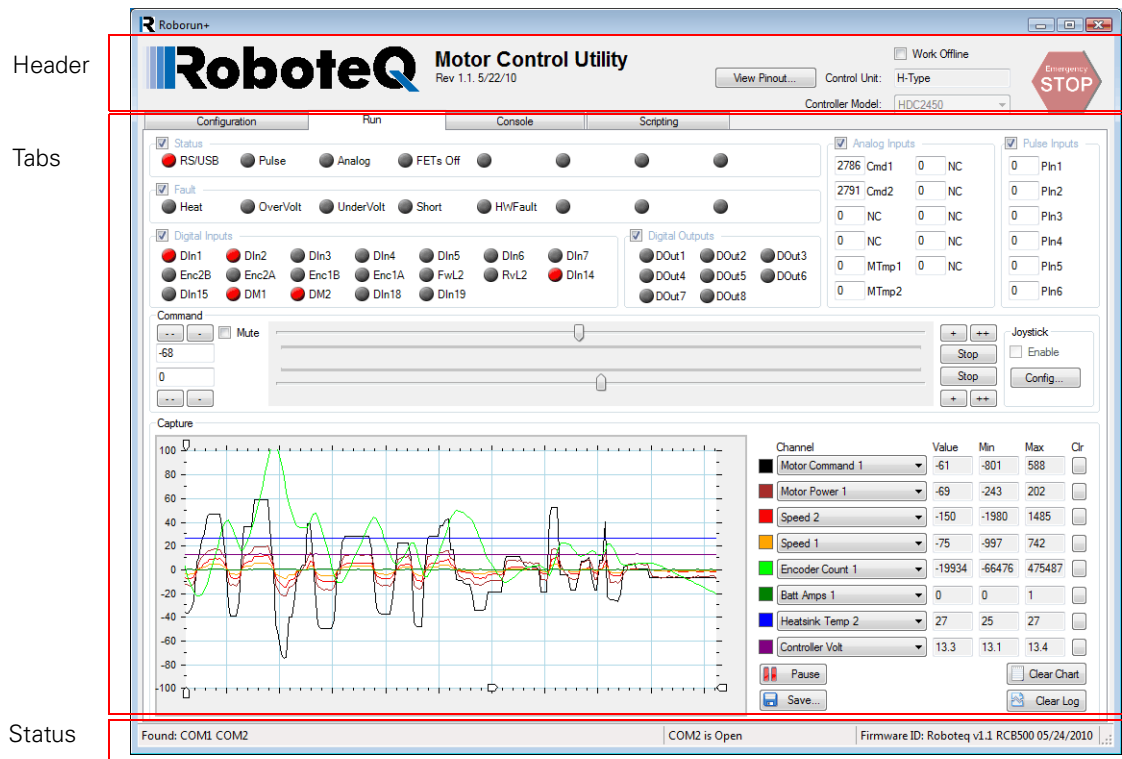

FIGURE 66. The Roborun+ Interface

The screen has a **header**, **status bar** and 4 tabs:

- **Configuration tab** for setting all the different configuration parameters;
- **Run tab** for testing and monitoring the status of the controller at runtime;
- **Console tab** for performing a number of low-level operations that are useful for upgrading, testing and troubleshooting;
- **Scripting tab** for writing, simulating, and downloading custom scripts to the controller.

Header Content

The header is always visible and contains an “**Emergency Stop**” button that can be hit at any time to stop the controller’s operation. Hitting the button again will resume the controller operation.

The header also displays inside two text boxes the Controller type that has been detected

Control Unit: Identifies the processing unit used it the controller

Controller Model: Identifies the complete model number reference

The “**View Pinout**” button will pop open a window showing the pinout of the detected controller model. For each analog, digital or pulse input/output, the table shows the default label (e.g. DIN1, AIN2, ...) or a user defined label (e.g. Limit1, eStop, ...). User definition of label names for I/O pins is done in the Configuration tab.

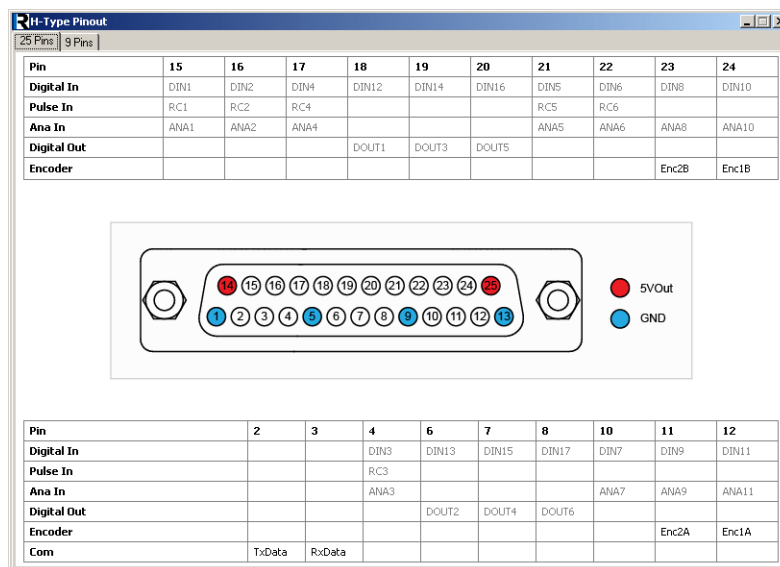

FIGURE 67. Pinout-View pop-up window

Clicking in the **Work Offline checkbox** allows you to manually select a controller model and populate the Configuration and Run trees with the features and functions that are available for that model. Working offline is useful for creating/editing configuration profiles without the need to have an actual controller attached to the PC.

Status Bar Content

The status bar is located at the bottom of the window and is split in 4 areas. From left to right:

- List of COM ports found on the PC
- COM port used for communication with the controller. “Port Open” indicates that communication with the controller is established.

- Firmware ID string as reported by the controller. Contains revision number and date.
- Connected/Disconnected LED. When lit green, it indicates that the communication with the controller is OK.

Program Launch and Controller Discovery

After launching the Roborun utility, if the controller is connected, or after you connect the controller, the Roborun will automatically scan all the PC's available communication ports.

The automatic scanning is particularly useful for controllers connected via USB, since it is not usually possible to know ahead of time which communication port the PC will assign to the controller.

If a controller is found on any of those ports, Roborun will:

- Display the controller model in the window header.
- Display the Connection COM port number, report the Firmware revision, and turn on the Connect LED in the Status bar.
- Pop up a message box asking you if you wish to read the configuration.

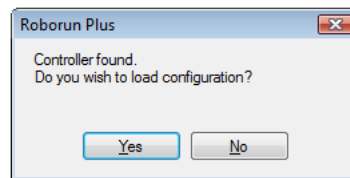

FIGURE 68. Pop up message when Controller is detected

Answering 'Yes', the Roborun will read all the configuration parameters that are stored into the controller's memory.

Note: If two or more controllers are connected to the same PC, Roborun will only detect one. Roborun will normally first detect the one assigned to the lowest COM port number, however, this is not entirely predictable. It is recommended that you only connect one controller at a time when using the PC utility.

Configuration Tab

The configuration tab is used to read, modify and write the controller’s many possible operating modes. It provides a user friendly interface for viewing and editing the configuration parameters described in “Set/Read Configuration Commands” on page 194.

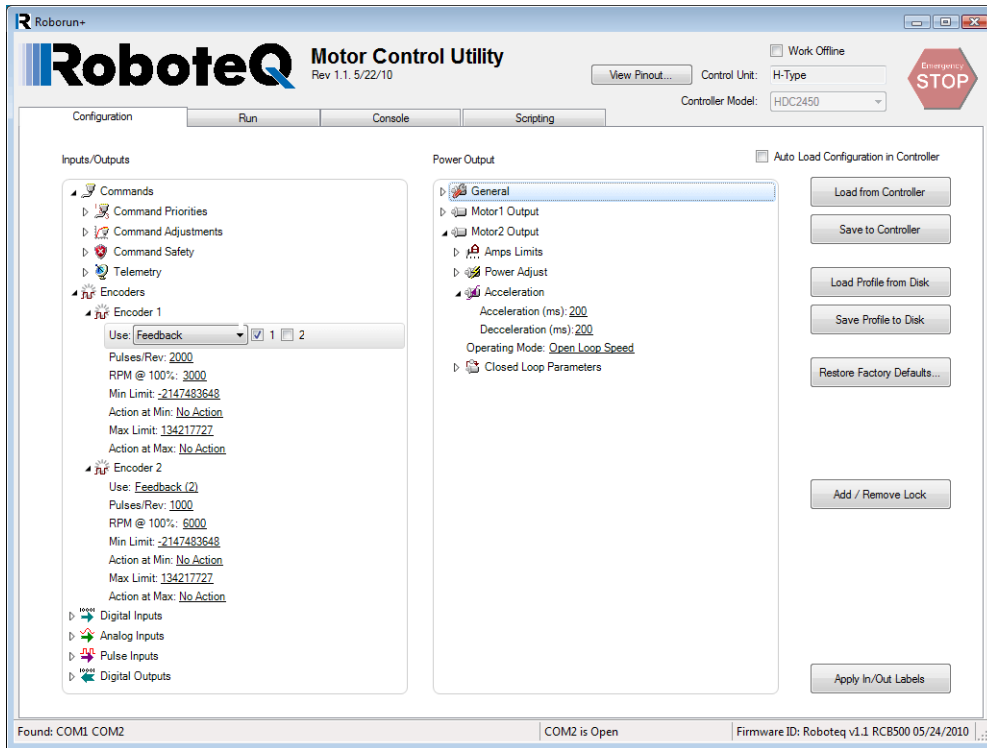

FIGURE 69. Configuration tab

The configuration tab contains two configuration trees: the one on the left deals mostly with the I/O and control signals, while the tree on the right deals with the power output and motor parameters. The exact content and layout of a tree depends on the controller model that is detected.

The trees are, for the most part, self explanatory and easy to follow.

Each node will expand when clicking on the small triangle next to it. When selecting a tree item, the value of that item will show up as an underscored value. Clicking on it enables a menu list or a freeform field that you can select to enter a new configuration values.

After changing a configuration, an orange star * appears next to that item, indicating that this parameter has been changed, but not yet saved to the controller.

Clicking on the **“Save to the controller”** button, moves this parameter into the controller’s RAM and it becomes effective immediately. This also also saves the parameter into the controller’s EEPROM so that it is loaded the next times the controller is powered up again.

Entering Parameter Values

Depending on the node type, values can be entered in one of many forms:

- Numerical
- Boolean (e.g. Enable/Disable)
- Selection List
- Text String

When entering a numerical value, that value is checked against the allowed minimum and maximum range for that parameter. If the entered value is lower than the minimum, then the minimum value will be used instead, if above the maximum, then the maximum value will be used as the entered parameter.

Boolean parameters, such as Enabled/Disabled will appear as a two-state menu list.

Some parameters, like Commands or Actions have the option to apply to one or the other of the motor channels. For this type of parameters, next to the menu list are checkboxes – one for each of the channels. Checking one or the other tells the controller to which channel this input or action should apply.

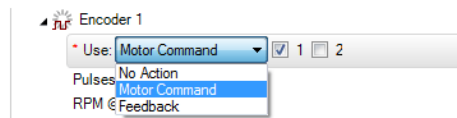

FIGURE 70. Parameter applying to one or more channels

String parameters are entered in plain text and they are checked against the maximum number of characters that are allowed for that string. If entering a string that is longer, the string is truncated to the maximum number of allowed characters.

Automatic Analog and Pulse input Calibration

Analog and Pulse inputs can be configured to have a user-defined minimum, maximum and center range. These parameters can be viewed and edited manually by expanding the Range subnode.

The minimum, maximum and center values can also be captured automatically by clicking on the “Calibrate” link.

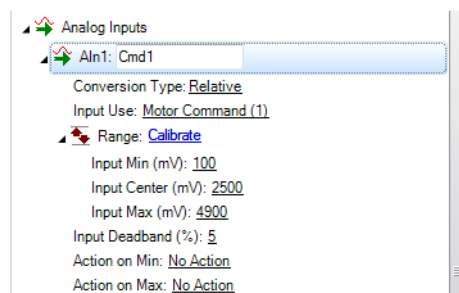

FIGURE 71. Min/Max/Center parameters and auto-calibration for Analog & Pulse Inputs

When clicking on the **“Calibrate”** link, a window pops up that displays a bar showing the live value of that analog or pulse input in real time.

The window contains three cursors that move in relation to the input, capturing the minimum and maximum detected values. It is possible to further manually adjust further these settings by moving the sliders. The Center value will be either the value of the inputs (or the joystick position) at the time when clicking on the **“Done”** button. The Center value can also be automatically computed to be the middle between Min and Max when enabling the **“Auto Center”** checkbox. Clicking on **“Reset”** resets the Min, Max and Center sliders and lets you restart the operation.

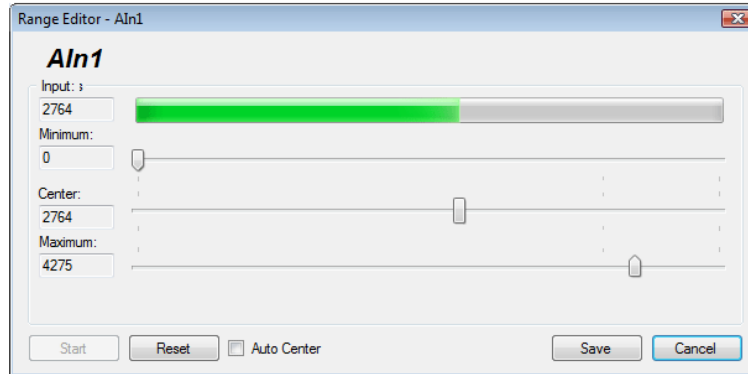

FIGURE 72. Auto calibration window

After clicking on the **“Done”** button, the capture values will appear in the Min, Max and Center nodes in the tree with the orange * next to them, indicating that they have changed but not yet be saved in the controller. At this point, they can be adjusted further manually and saved in the controller.

Input/Output Labeling

Each analog, digital or pulse input/output, is given default label (e.g. DIN1, AIN2, ...). Alternatively, it is possible to assign or a user defined label name (e.g. Limit1, eStop, ...) to each of these signals. This label will then appear in the Run Tab next to the LED or Value box. The label will also appear in the Pin View window (See Figure 67, “Pinout-View pop-up window,” on page 227). Custom labels make it much easier to monitor the controller’s activity in the Run tab.

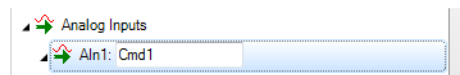

FIGURE 73. Labeling an Input/Output

To label an Input or Output, simply select it in the tree. A text field will appear in which you can enter the label name. Beware that while it is possible to enter a long label, names with more than 8 letters will typically appear truncated in the Run tab.

Loading, Saving Controller Parameters

The buttons on the right of the Configuration tab let you load parameters from the controller at any time and save parameters typically after a new parameter has been changed in the trees.

You can save a configuration profile to disk and load it back into the tree.

The **“Reset Defaults ...”** button lets you reset the controller back to the factory settings. This button will also clear the custom labels if any were created.

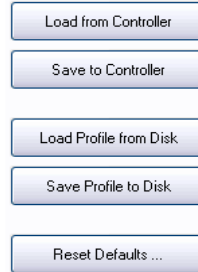

FIGURE 74. Loading & Saving parameters buttons

Locking & Unlocking Configuration Access

The **“Add/Remove Lock”** button is used to lock the configuration so that it cannot be read by unauthorized users. Given the many configuration possibilities of the controller, this locking mechanism can provide a good level of Intellectual Property protection to the system integrator.



FIGURE 75. Add/Remove lock button

If the controller is not already locked, clicking on this buttons pops up a window in which you can enter a secret number. The number is a 32-bit value and so can range from 1 to 4294967296.

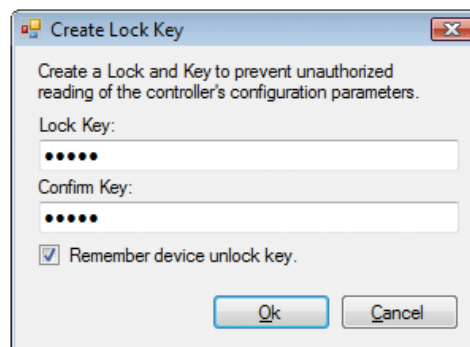

FIGURE 76. Lock creation window

That secret number gets stored inside the controller with no way to read it.

Once locked, any time there is an attempt to read the controller configuration (as for example, when the controller is first detected), a message box will pop open to indicate that the configuration cannot be read. The user is prompted to enter the key to unlock the controller and read the configuration.

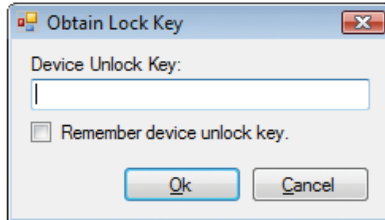

FIGURE 77. Controller unlock window

Note that configuration can be set even when the controller is locked, only read cannot be performed.

Configuration Parameters Grouping & Organization

The total number of configuration parameters is quite large. While most system will operate well using the default values, when change is necessary, viewing and editing parameters is made easy thanks to a logical graphical organization of these parameters inside collapsible tree lists.

The configuration tab contains two trees. The left tree includes all parameters that deal with the Analog, Digital, Pulse I/O, encoder and communication. The right tree includes all parameters related to the power drive section. The exact content of the trees changes according to the controller that is attached to the PC.

Commands Parameters

See “Command Inputs Configuration and Safety” on page 195 for details on this group of parameters.

In the commands menu we can set the command priorities, the linearization or exponentiation that must be performed on that input.

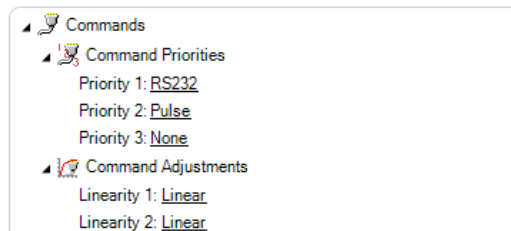

FIGURE 78. Commands parameters

Then a number of Command Safety parameters can be configured. These are the Watchdog timeout when receiving Serial commands, and the safety ranges for analog commands.

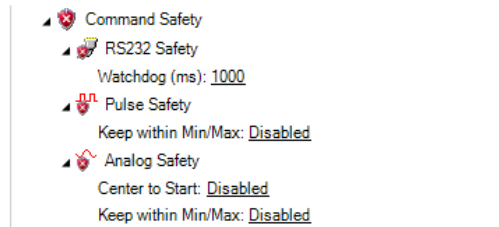

FIGURE 79. Command Safety parameters

The Telemetry parameter contains the string that is executed whenever controller is first powered up. This parameter is typically loaded with a series of real-time queries that the controller automatically and periodically perform. Queries must be separated with the ":" colon character. The string is normally terminated with the command to repeat ("##") followed by the repeated rate in milliseconds. See "TELS - Telemetry String" on page 198 and "Query History Commands" on page 188 for details on Telemetry.

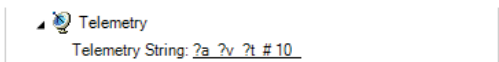

FIGURE 80. Telemetry

Encoder Parameters

See "Encoder Operations" on page 208 for details on this group of parameters.

In the Encoder node are all the parameters relevant to the usage of the encoder. The first parameter is the Use and is used to select what this encoder will be used for and to which motor channel it applies. Additional parameters let you set a number of Pulse Per Revolution, Maximum Speed and actions to do when certain limit counts are reached.

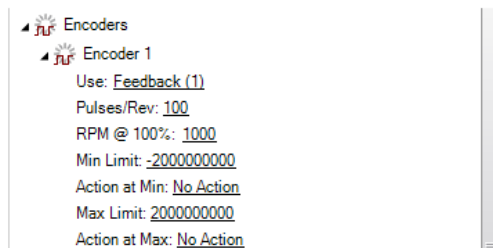

FIGURE 81. Encoder parameters

Digital Input and Output Parameters

See “Digital Input/Output Configurations” on page 199 for details on this group of parameters.

For Digital inputs, you can set the Active Level and select which action input should cause when it is activated and on which motor channel that action should apply.

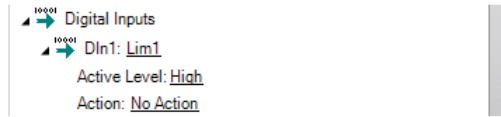

FIGURE 82. Digital Input parameters

For Digital Output, you can set the Active Level and the trigger source that will activate the Output.

Analog Input Parameters

See “Analog Input Configurations” on page 201 for details on this group of parameters.

For Analog inputs, all the parameters that can be selected include the enabling and conversion type what this input should be used for and for which channel the input range limits the deadband and which actions to perform when the minimum or maximum values are reached.

Pulse Input Parameters

See “Pulse Input Configuration” on page 205 for details on this group of parameters

For Pulse inputs, the tree lets us enable that input and select what it is used for and what type of capture it is to make. The range, deadband and actions to take on when Min and Max are reached is also selectable.

Power Settings

See “General Power Stage Configuration Commands” on page 214 for details on this group of parameters

The power output tree sets parameters that relate to the motor driver and power stage of the controller. There is one tree for setting parameters that apply to all channels of the controller. These are: the PWM Frequency, the low and high side Voltage Limits, the Short Circuit Protection and the mixed mode.

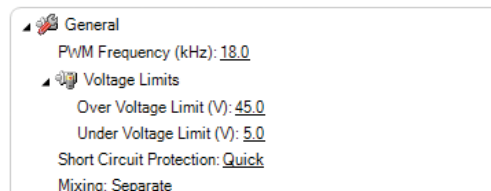

FIGURE 83. General Power Stage configuration parameters

The parameters for each motor are typically duplicated so that they can be set separately for each motor. Expanding the node shows that we can set the Amps limit that the controller will actively control the power output in order to not exceed it.

An Amps trigger value, which if reached for a preset amount of time, will trigger a user selectable Action. This feature can be used in order to implement stall protection, or current-based limit switches.

The Power Adjust sets the maximum power that will be applied to the output at 100%. The maximum power can be different for the forward and reverse directions. This feature can be used to limit the maximum speed in a given direction or to enable lower voltage motors to be used with the higher voltage battery.

The Acceleration parameter lets you set the Acceleration and Deceleration values.

In this tree also can be set the Operating Mode for that channel: Open Loop, Closed Loop Speed or Closed Loop Position.

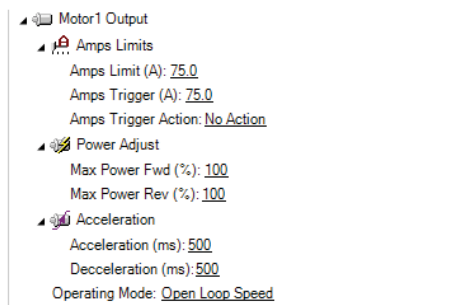

FIGURE 84. Motor Output parameters

When operating in the Closed Loop, the Closed Loop parameters let you set the closed loop parameters such as PID gain.

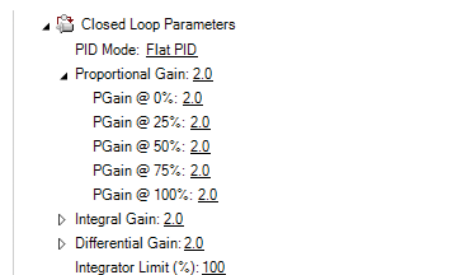

FIGURE 85. Closed Loop parameters

Run Tab

The Run tab lets you exercise the motors and visualize all the inputs and outputs of the controller.

A powerful chart recorder is provided to plot real-time controller parameters on the PC, and/or log to a file for later analysis.

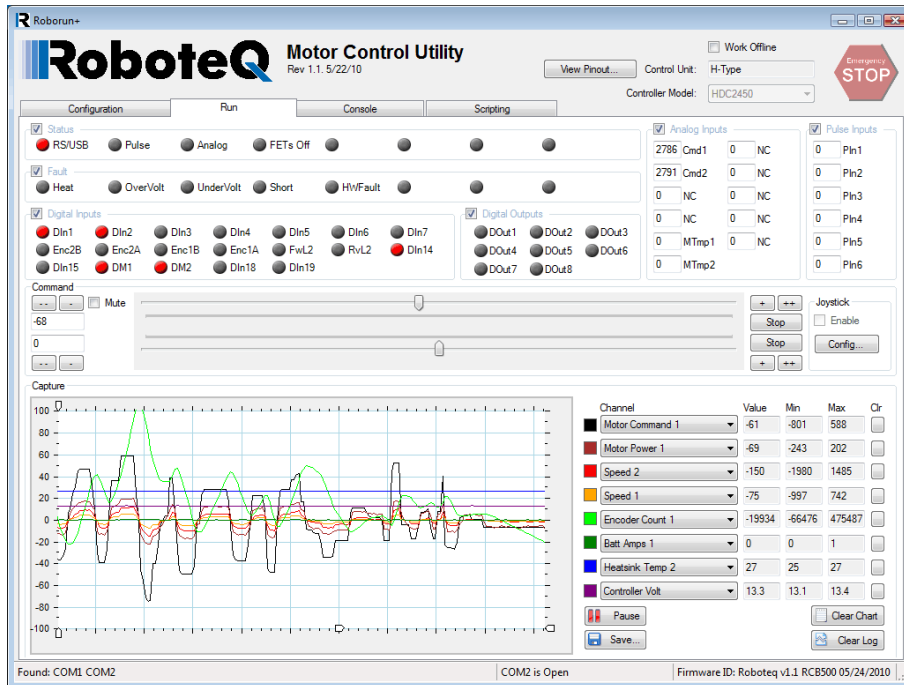

FIGURE 86. Run tab

Each group of monitored parameters can be disabled with a checkbox at the upper left corner of their frame. By default, all are enabled. Disabling one or more will increase the capture resolution in the chart and log of the remaining ones.

Status and Fault Monitoring

Status LEDs show the real-time state of key operating flags. The meaning of each LED is displayed next to it and can vary from one controller to another.

The Fault LEDs indicate all fault conditions. Any one LED that is lit will cause the controller to disable the power to all motor output channels. The meaning of each LED is displayed next to it and can vary from one controller to another.

The Config Fault LED indicates that an invalid configuration is read from the controller. This would be an extremely unlikely occurrence, but if it happens, restore the default configuration and then reload your custom configuration.

The EEPROM error signals a hardware fault with the controller's configuration storage device. If the problem persists, please contact Roboteq for repair.

Applying Motor Commands

The command sliders will cause the command value to be applied to the controller. Clicking on the “+”, “++”, “-”, “--” buttons lets you fine-tune the command that is applied to the controller. The numerical value can be entered manually by entering a number in the text box.

The **“Mute”** checkbox can be selected to stop all commands from being sent to the controller. When this is done, only parameter reads are performed. When commands are muted and if the watchdog timer is enabled, the controller will detect a loss of commands arriving from the serial port and depending on the priorities it will switch back to the RC or Analog mode.

If a USB Joystick is connected to the PC and the **“Enable”** box is checked, the slider will update in real-time with the captured joystick position value. This makes it possible to operate the motor with the joystick. The **“Configure Joystick”** button lets you perform additional adjustments such as inverting and swapping joystick input.

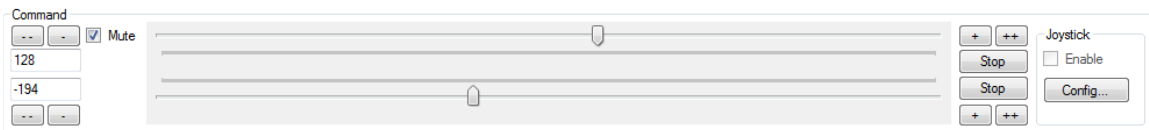

FIGURE 87.

Digital, Analog and Pulse Input Monitoring

The status of Digital inputs and the value Analog and Pulse can be monitored in real-time. Analog and Pulse inputs will update only if the selected channel is enabled. The labels for the digital inputs, digital outputs, analog inputs and pulse inputs can be made to take the value that has been entered in the configuration tree as described in “Input/Output Labeling” on page 231. Using a nickname for that signal makes it easier to monitor that information.

Digital Output Activation and Monitoring

The Digital output LEDs reflect the actual state of each of the controller’s Output. If an output is not changed by the controller using one of the available automatic Output Triggers (see “DOA” on page 200), clicking on the LED will cause the selected output to toggle On and Off.

Using the Chart Recorder

A powerful chart recorder is provided for real-time capture and plotting of operating parameters. This chart can display up to eight operating parameters at the same time. Each of the chart’s channels has a pull-down menu that shows all of the operating parameters that can be viewed and plotted. The colors can be changed by clicking on the color icon and selecting another color.

When selecting a parameter to display, this parameter will appear in the chart and change in real-time. The three boxes show a numerical representation of the actual value and the Min and Max value reached by this input. Clicking on the **“Clear”** button for that channel

resets the Min and Max. The chart can be paused or it can be cleared and the recorded values can be saved in an Excel format for later analysis.

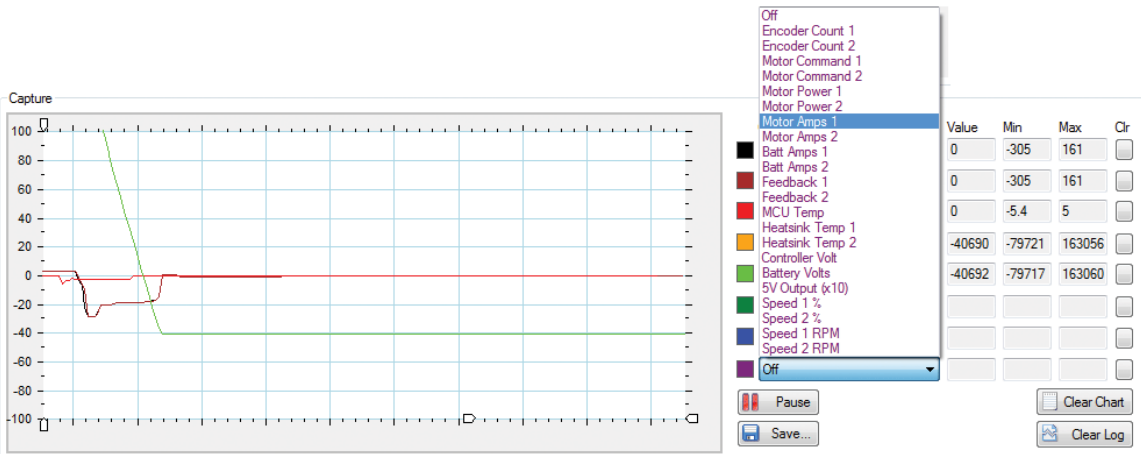

FIGURE 88. Chart recorder

“Handles” on the left vertical axis may be used to zoom in a particular vertical range. Similar handles on the horizontal axis can be used to change the scrolling speed of the chart.

Console Tab

The console tab is useful for practicing low-level commands and viewing the raw data exchanged by the controller and the PC. The Console tab also contains the buttons for performing field updates of the controller.

Text-Mode Commands Communication

The console mode allows you to send low-level commands and view the raw controller responses. Ten text fields are provided in which you can type commands and send them in any sequence by clicking on the respective **“Send”** button. All the traffic that is exchanged by the controller and the PC is logged in the console box on the right. It is then possible to copy that information and paste it into a word processor or an Excel spreadsheet for further analysis.

The **“Stop”** button sends the **“#”** command to the controller and will stop the automatic query updating if it is currently active.

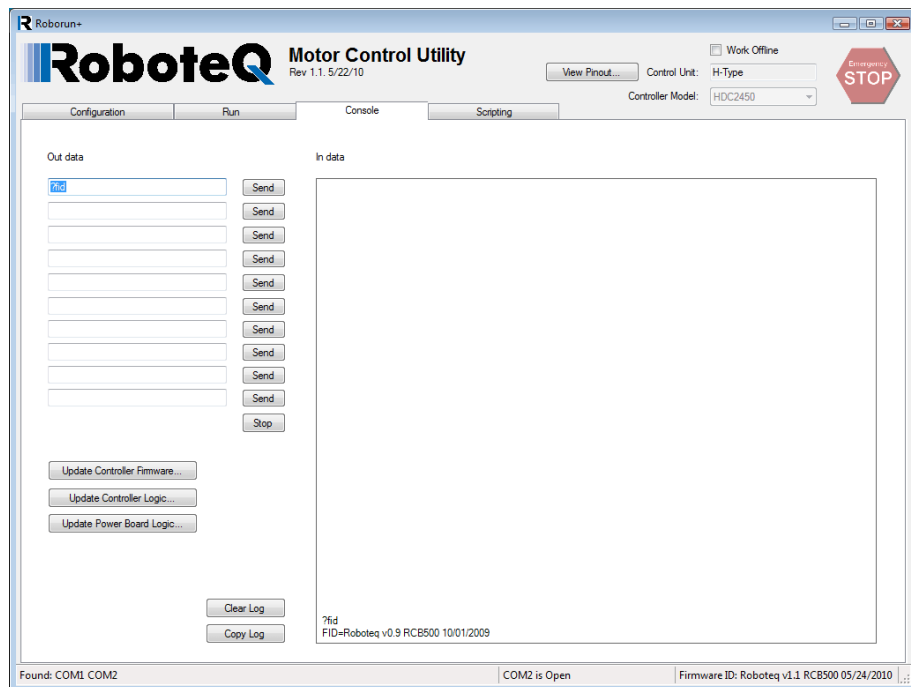

FIGURE 89. Console tab

Updating the Controller’s Firmware

The controller’s firmware can be updated in the field. This function allows the controller to be always be up-to date with the latest features or to install custom firmware. Update can be done via the serial port or via USB for USB-fitted models.

To update the controller firmware, click on the **“Update”** button and you can let controller automatically process the update after you have browsed for and selected the new firmware file. The log and checkboxes show the progress of the operation.

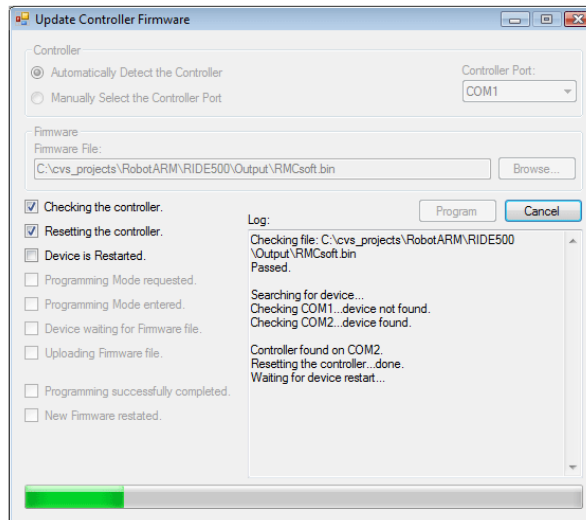

FIGURE 90. Update Controller Firmware window

When updating via USB, click on the Update firmware with USB. This will cause the COM port to close and the device to disappear from PC utility. The controller then enters a special update mode and will automatically launch the Roboteq **“DFU Loader”** utility that is found in the Start menu. Selecting and updating the file will perform the firmware update via USB. After completion, cycling power will restart the controller. It will then be found by the PC utility.

Updating the Controller Logic

The controller has a couple of programmable logic parts which can also be updated in the field. Updating the logic must only be done only when the power stage is off and the controller is powered only with the power control wire. No I/O must be connected on the front connectors either.

To update the logic, click on the **“Update Power Board Logic”** or **“Update Controller Logic”**; select the file and click on the **“Program”** button. The log shows the steps that are taking place during the process. The process last approximately 30 sec., do not cancel the programming in the middle of programming even if it looks that there is no progress. Cancel only after over a minute of inactivity. Never turn off the power while programming is in progress.

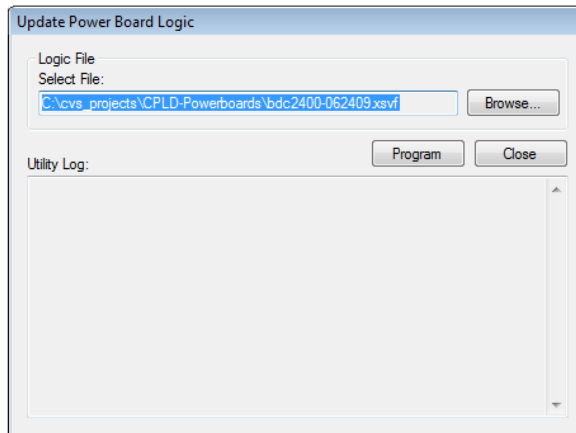

FIGURE 91. Update Power Board Logic window

After updating the logic, you should turn off and turn on the controller in order for the changes to be fully accounted for.

Scripting Tab

One of the controller’s most powerful and innovative features is the ability for the user to write programs that are permanently saved into, and run from the controller’s Flash Memory. This capability is the equivalent of combining the motor controller functionality and this of a PLC or Single Board Computer directly into the controller. The scripting tab is used to write, simulate, and download custom scripts to the controller.

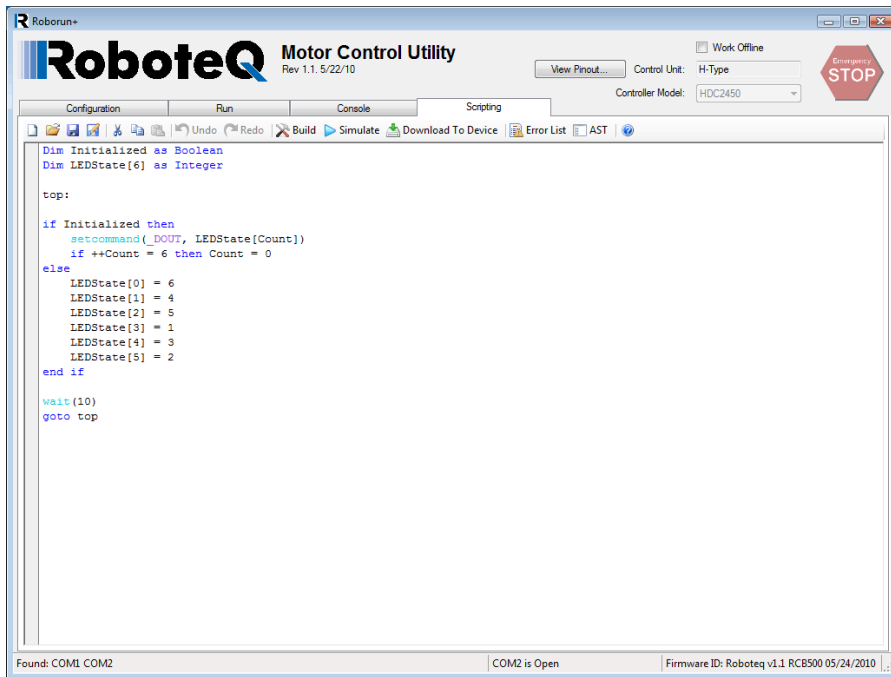

FIGURE 92. Scripting tab

Edit Window

The main window in this tab is used to enter the scripts. The editor automatically changes the color and style of the entered text so that comments, keywords, commands and text strings are immediately recognizable. The editor has vary basic text editing features needed to write source code. More information on the scripting language and its capabilities can be found in the “MicroBasic Language Reference” on page 143.

Download to Device button

Clicking on this button will cause the source code to be immediately interpreted in low level instructions that are understandable by the controller. If no errors are found during the translation, the code is automatically transferred in the controller's flash memory.

Build button

Clicking on this button will cause the source code to be immediately interpreted in low level instructions that are understandable by the controller. A window then pops up showing the result of the translation. The code is not downloaded into the controller. This command is generally not needed. It may be used to see how many bytes will be taken by the script inside the controller's flash.

Simulation button

Clicking on the **“Simulate”** button will cause the source code to be interpreted and run in simulation mode on the PC. This function is useful for simplifying script development and debug. The simulator will operate identically to the real controller except for all commands that normally read or write controller configuration and operation data. For these commands, the simulated program will prompt the programmer for values to be entered manually, or output data to the console.

Executing Scripts

Scripts are not automatically executed after the transfer. To execute manually, you must click on the Run tab and send the !r command via the console. Unless a script includes print statements, it will run silently with no visible signs. Clicking on !r 0 will stop a script, !r or !r 1 will resume a stopped script. !r 2 will clear all variables and restart a script.