

Skywire[®] Cellular Modem Hardware Developer's Guide

NimbeLink Corp

Updated: November 2018



© NimbeLink Corp. 2018. All rights reserved.

NimbeLink Corp. provides this documentation in support of its products for the internal use of its current and prospective customers. The publication of this document does not create any other right or license in any party to use any content contained in or referred to in this document and any modification or redistribution of this document is not permitted.

While efforts are made to ensure accuracy, typographical and other errors may exist in this document. NimbeLink reserves the right to modify or discontinue its products and to modify this and any other product documentation at any time.

All NimbeLink products are sold subject to its published Terms and Conditions, subject to any separate terms agreed with its customers. No warranty of any type is extended by publication of this documentation, including, but not limited to, implied warranties of merchantability, fitness for a particular purpose and non-infringement.

NimbeLink is a registered trademark, and Skywire is a registered trademark, of NimbeLink Corp. All trademarks, service marks and similar designations referenced in this document are the property of their respective owners.

Table of Contents

Table of Contents	2
Introduction	4
Skywire Modem Overview	4
Skywire Modem Categories	4
Design Resources	5
Mechanical Drawing	7
Skywire Pin Description	8
System Architecture	10
Skywire Integration	12
Serial Communications	12
Serial UART Interface	12
USB Interface	13
Power	13
Power Supply design Guidelines	14
Power Control	15
ON_OFF Signal	15
Shutdown	15
VREF	16
DTR/WAKE	17
Status Monitoring	17
Ring Indicator	17
GPIOx	17
Power Monitoring with a modem's GPIO pin	17
SIM Cards	17
ESD	18
Layout & Schematic Considerations	18
Layout Examples	18
Enclosure Considerations	21
Skywire Antenna Considerations	22
Skywire Antenna Connections	22
Antenna Considerations	22
System Verification	24
Operational tests	24

Stress Testing	24
End of Line Testing	25
Steps Performed at NimbeLink Factory	26
Data Plans	26
Certification Considerations	27
FCC & IC Intentional Radiator	27
FCC Emissions	27
Colocation of Radio Systems	27
Carrier Specific	27

1. Introduction

This document helps OEM integrators plan and implement successful designs using NimbeLink's Skywire cellular modems. It details the recommended guidelines that should be followed in order to successfully integrate Skywire modems into end products. This guide is applicable to all Skywire modems.

Throughout this document modems might be referred to as their 4 or 5 digit abbreviated part number. For instance, the NL-SW-LTE-QBG96 might be referred to as the QBG96.

Please direct any questions to NimbeLink's product support team at product.support@nimbelink.com.

1.1 Skywire Modem Overview

NimbeLink's Skywire Cellular modems are purpose-designed to enable rapid IoT & M2M application development. Each modem has full regulatory and carrier end-device certifications for the regions they are designed to operate in. The modems' certifications save users from having to perform carrier testing, along with third party test lab fees. Additionally, all maintenance releases, recertification, and sustaining engineering are managed by NimbeLink.

Skywire modems are among the smallest embedded modems in the industry. They are compatible with a wide range of Skywire development kits and microprocessor shields, helping to accelerate product development and prototyping.

All Skywire modems conform to the same 34mm by 29mm mechanical form factor and share a common 20 pin Skywire interface. This allows customers to design one board that supports multiple types of cellular connectivity options via the Skywire modem. Using the Skywire modem designers can design their board once, and use any of the Skywire modems to connect anywhere.

1.2 Skywire Modem Categories

The Skywire family of modems allow OEM integrators to add any cellular technology from LTE CAT 4 down to LTE-M1 and NB-IoT to their system.

LTE CAT 4 Skywire modems offer the highest possible data rates of any Skywire modem, with maximum peak download rates of 150 Mbps & upload rates of up to 50 Mbps, subject to carrier limitations. They are ideal for:

- M2M mobile broadband applications requiring high bandwidth
- Low latency streaming data
- Cellular failover

These modems are designed for use in:

- Mobile terminals
- Digital signage
- Video systems
- M2M applications requiring high data rates.

LTE CAT 1 Skywire modems bridge the gap between the high speed LTE CAT 3 or LTE CAT 4 modems and the power optimized LTE M1/NB-IoT modems. These modems are optimized to enable high data rates, reaching 10 Mbps down & 5 Mbps up, while reducing the modem's cost. LTE CAT 1 modems are ideal for the medium bandwidth, low latency data streaming applications such as:

- Digital signage
- ATMs
- Kiosks
- Video surveillance
- Vehicle telematics
- Cellular gateways.

LTE CAT M1 & NB-IoT Skywire modems have the lowest power requirements of any cellular modem type, making them ideal for low data rate (<1MB/month), battery operated, or off-grid applications. Depending on the application, they may be able to run for years unattended and without requiring a battery replacement or recharge. These modems are power and cost optimized to enable low cost cellular connectivity for IoT and M2M applications, making them ideal for battery powered products.

1.3 Design Resources

NimbeLink offers multiple development kits to serve as free reference designs to assist customers with their designs. Each reference design includes the full schematic, Gerbers, BOM, CAD design files, and user manuals on how to use the kit.

Several of the designs are linked below:

- [Skywire Development Kit](#)
- [BeagleBone Skywire Development Kit](#)
- [Raspberry Pi Skywire Development Kit](#)

Additional development kit reference designs can be found here:

- [Skywire Development Kits](#)

While prototyping with the modem, it is recommended to use a Skywire development kit, as opposed to a breadboard. Please refer to the following application note on why breadboards might cause power problems and how to fix them:

- [Skywire Prototyping Design Considerations](#)

The following documents or documentation resources are recommended for users to review in addition to this guide.

- [Skywire Modem Selection Page](#)
- [Skywire Modem Development Kit Selection Page](#)
- [Skywire Hardware Design Checklist](#)
- [Skywire Software Developer's Guide](#)

As part of the documentation package for every Skywire modem, a 3D mechanical model is generated and provided on the product page under the "Documents" section. Share this file with your Mechanical Engineer to ease the enclosure design process.

Should any questions around how to use a Skywire modem arise, please reach out to our product support team at product.support@nimbelink.com.

2. Mechanical Drawing

The following is a generic mechanical drawing of the Skywire modem showing the modem's formfactor. The height of the modem may vary slightly due to height differences in the cellular module used on the modem. Exact mechanical drawings for each modem are available in their respective Datasheet.

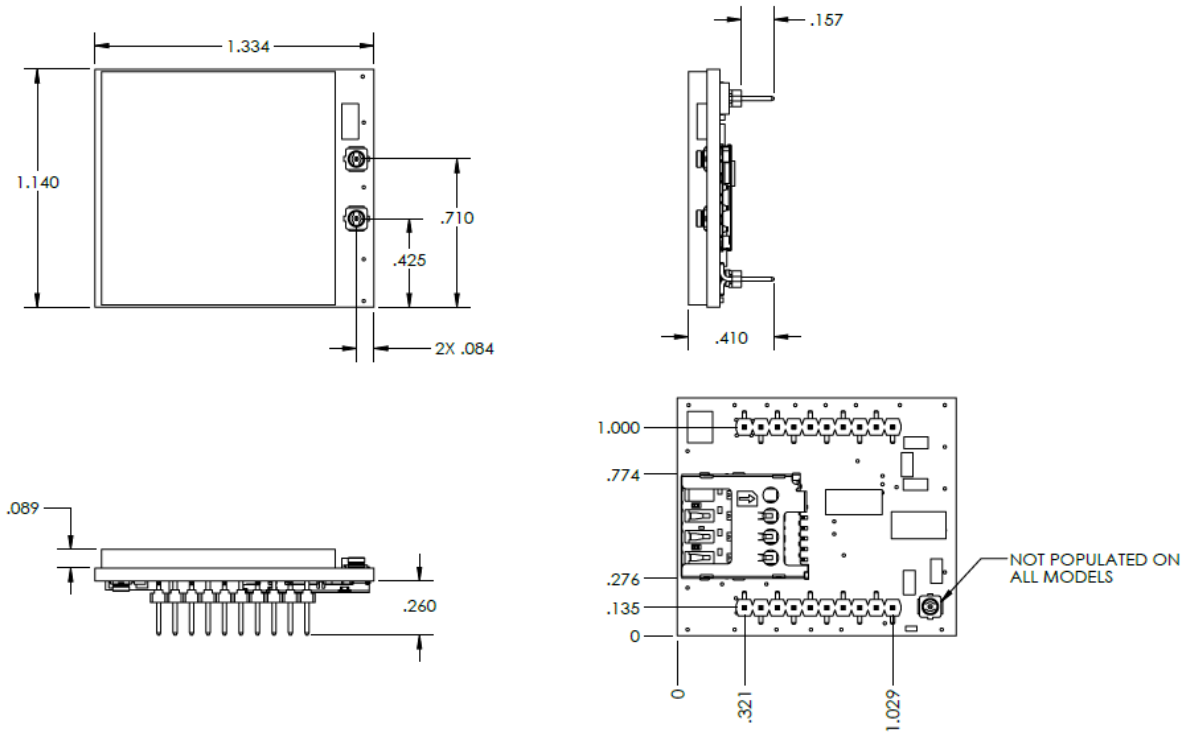

3. Skywire Pin Description

The following tables detail the pinout functionality of the various Skywire modems.

Skywire Socket PIN				Description
No.	Modem	Name	I/O	
1	All	VCC	I	Supply Voltage Input.
2	All	DOUT	O	Serial UART Data Output.
3	All	DIN	I	Serial UART Data Input.
4, 10, 11, 15	All	GND		Ground Pin. Must be directly connected to common ground plane.
5	All	nRESET	I	Emergency reset pin. Must be driven with an open drain or open collector signal. This signal should only be used as a last resort.
6	All	VUSB	I	USB Power Detection Pin. This pin is used by the module to turn on the USB interface and should be controlled by the host systems USB controller.
7	All	USB D+	I/O	USB D+ Data Pin.
8	All	USB D-	I/O	USB D- Data Pin.
9	SVZM20	WAKE	I	Wakeup input pin. Used to to wake the modem from sleep modes.
	WM14	nWake_IN	I	Wakeup input pin. Used to to wake the modem from sleep modes.
	All Others	DTR	I	Data Terminal Ready Input Pin. Many modems will also use this pin as part of their PSM mode configuration.
12	All	CTS	O	Clear to send hardware flow control output
13	QBG96	STATUS	O	Modem Status Pin. Signal drives high when modem is on.
	SVZM20	ON_STATUS	O	Modem Status Pin. Signal drives high when modem is on and ready for AT commands.
	S7588, S7648, S7618RD	VGPIO	O	Modem Status Pin. Signal drives high when modem is on and ready for AT commands.
	GELS3	V180	O	Modem Status Pin. Signal drives high when modem is on.
	TM1G, TSVG, TEUG, TNAG, HSPA	ON/nSLEEP	O	Network Status Indication Pin. Operation will vary depending on underlying configuration. See modem(s) datasheet for more details.
	WM14	nWAKE_OUT	O	Wakeup Output pin. Used to alert host or acknowledge it is ready following a wakeup request from the host.

14	ALL	VREF	I	External System I/O Reference Input.
16	ALL	RTS	I	Ready to send hardware flow control input
17	QBG96	I2C SDA		1.8V I2C Data Signal for I2C output from the cellular module. Requires 4.7Kohm pull-up to 1.8V.
	SVZM20	Reserved		This pin is reserved and should be NC
	S7588, S7648, S7618RD, GELS3, TM1G, TSVG, TEUG, TNAG, HSPA, WM14	GPIOx	I/O	Programable 1.8V GPIO
18	QBG96	I2C SCL		1.8V I2C Clock Signal for I2C output from the cellular module. Requires 4.7Kohm pull-up to 1.8V.
	SVZM20	Reserved		This pin is reserved and should be NC
	S7588, S7648, S7618RD, GELS3, TM1G, TSVG, TEUG, TNAG, HSPA, WM14	GPIOx	I/O	Programable 1.8V GPIO
19	QBG96, TM1G, SVZM20	RING	O	Ring Indicator output pin. Used to alert host of incoming network traffic.
	S7588, S7648, S7618RD, TSVG, TEUG, TNAG, HSPA, WM14, GELS3	ADC1	I	ADC input into cellular module. 1.8V, 8-bit or 10-bit resolution depending on modem.
20	ALL	ON_OFF or PWR_ON	I	ON_OFF signal pin. Used to turn on the modem. Must be driven with an open drain or open collector signal.

Skywire Connectors			Description
No.	Modem	Name	
X1	All	Primary RF	Primary Cellular Antenna Connection.
X2	S7588, S7648, S7618RD, GELS3, TM1G, TSVG, TEUG, TNAG, HSPA, WM14	Diversity RF	Diversity Cellular Antenna Connection.
X3	TSVG, TNAG, TEUG, TM1G, HSPA, QBG96	GNSS RF	GNSS RF connector, connect to active GNSS antenna.
SIM	All	SIM Card Socket	3FF SIM Card Socket located on the underside of all Skywire modems.

4. System Architecture

There are three primary design considerations that OEM integrators must take into account when designing in a Skywire modem:

1. How is the system going to communicate and control with the modem?
2. How will the modem be powered?
3. How will the modem's firmware be updated?

The Skywire modem has two communications paths, a Serial UART and a USB 2.0 interface. System architects will need to determine which interface best suits their design requirements - this will often depend on what kind of processor the OEM is interfacing the modem to.

For designs using an application processor that is running a operating system, such as Windows or Linux, using the USB interface is the recommended path. The operating system will often have built in driver support for the modem's USB interface which simplifies the software integration. The USB interface will also allow the operating system to take advantage of the modem's maximum data throughput when compared to the serial interface. The USB interface on all Skywires, except the SVZM20, will enumerate multiple USB interfaces to allow for multiple communications paths. (such as: AT command port, GNSS NEMA data, dedicated network interfaces)

For systems using microcontrollers the UART is the recommended path, as USB modem support for RTOS or bare metal environments is limited. The serial UART interface is simple to interact with.

Recommendations for how to interface properly with the modem's communication interfaces are available in Section 5.1.

OEMs must also consider how the host processor will interact with the modem's other control signals, such as the ON_OFF and nRESET pins. These signals are critical control signals for the modems and if they are not controlled by the host system then the system may not operate. Details on the operation of the modem's control signals are discussed in Section 5.

The second critical architecture consideration deals with how the modem will be powered. Cellular modems consume significantly more instantaneous power than other LPWAN devices. The selected power supply must be able to withstand the rigorous current requirements of the a cellular modem in order to implement a successful design. Designs with lackluster power supplies will often run into brownout issues that may damage the modem. NimbeLink strongly encourages OEM integrators to follow the power supply design guidelines detailed in Section 5.2.

The final major consideration that system architects must make when integrating the Skywire modem deals with how the modem's firmware will be updated when it is deployed. LTE networks are constantly being updated, improved, and enhanced with new features. Most changes will not negatively affect devices connected to those

networks, but occasionally an update will prevent an unprepared device from connecting to the network permanently.

To account for these future changes, FOTA (Firmware over the Air) update capability has been added to cellular modules by each manufacturer. Accordingly, NimbeLink supports this functionality in the entire Skywire family of embedded modems. As such, it is highly recommended that designers implement provisions to accommodate for FOTA processes.

Failure to accommodate FOTA processes may result in interruptions in cellular connectivity in the event of network changes. If a device can no longer access the network, FOTA cannot be used to remedy the problem. The only way to recover functionality is to physically update the device firmware.

FOTA Instructions are available by contacting NimbeLink's product support team at product.support@nimbelink.com.

5. Skywire Integration

The following section details various design considerations that system designers should follow when designing the Skywire modem into their system. NimbeLink offers schematic and layout design reviews for customers integrating a Skywire modem into their design.

For more details please reach out to the NimbeLink product support team at product.support@nimbelink.com.

5.1 Serial Communications

Skywire modems have two communication paths: serial (UART) and USB. The serial UART interface is targeted for applications using lower speed 8/16/32 bit microcontrollers that do not have a USB interface or easily available USB interface drivers. The USB interface is meant for use by application processors that are running an operating system

5.1.1 Serial UART Interface

All Skywire modems support a serial UART interface with transmit and receive on pins 2 (DOUT) and 3 (DIN). On most modems, the baud rate defaults to 115200 baud 8N1, however the NL-SW-LTE-SVZM20 defaults to 921600 baud 8N1. If a different baud rate is required, it can be changed with the **AT+IPR** command as defined in the AT command manual.

Modems also support RTS/CTS flow control on pins 12 (CTS) and 16 (RTS). Depending on the modem flow control may or may not be enabled by default. To modify the flow control setting please refer to the specific modem's AT command manual. It is recommended that any designs using the serial UART interface connect the RTS/CTS flow control lines to the host microcontroller and enable them in their application. Failure to use flow control may result in the host system losing data. The flow control interface to the modems are connected as a DCE connection (CTS<-> CTS and RTS <-> RTS).

The serial interface on the Skywire works best when the microcontroller and modem are on the same PCB. If these two components are on different PCBs connected by a cable or connector, the designer may need to use additional buffer components.

For designs that are only using the serial UART interface, NimbeLink recommends designers include test points or a non-populated USB connector footprint in their designs. This allows access to the modem's USB interface to enable firmware updates and easier debugging.

5.1.2 USB Interface

Skywire modems support a USB 2.0 interface on pins 6 (VUSB), 7 (USB_P), and 8 (USB_N). Systems connecting to the modem's USB interface must observe proper design practices for connecting to a high speed USB device including, but not limited to, the following:

- The USB D± traces should be routed as a 90 ohm impedance differential pair.
- The USB D± traces should length matched.
- USB trace lengths should be minimized.
- There should be no stubs on the USB D± traces
- USB differential pairs should be carefully routed to ensure they have a continuous return path beneath the traces. Do not route differential pairs over splits in ground or power planes.
- If the USB signals will be used off-board, ESD protection should be implemented near the off-board connector.

Pin 6 is the VUSB detection pin that the modem uses to detect if a USB host controller has been connected to the modem. This pin must have a voltage applied to it in order to activate the USB interface and should be controlled by the host system's USB interface. It is not recommended to hardwire the VUSB pin directly to VCC or 5V as this may interfere with USB enumeration or the shutdown of the modem .

The input voltage to the VUSB pin will vary by modem. Please refer to the specific modem's datasheet that you are working with for additional information. The VUSB pin will draw less than 5mA when connected. VUSB must be disconnected or asserted to ground before activating Power Saving Mode.

5.2 Power

Skywire modems will regularly consume high amounts of current on their Power Supply input (Pin 1, VCC), up to 1.5A during LTE transmits and receives, and GSM connections will repeatedly hit 2A during transmissions. These current transients will often take the modem from consuming ~100mA to >1A in just a few microseconds.

In order to maintain compatibility with other 4G Skywire modems, the baseboard power supply should be designed to support peak currents of at least 2 Amps. The power trace leading from the power supply must be wide enough to ensure a low inductance path between the power supply, capacitors, and the VCC pin.

Skywire modems have a recommended input voltage of 3.90V. This recommended input voltage is chosen as the optimal input voltage to maximize power efficiency of the modem's internal power systems. While the modems do support a fairly wide input voltage range, it is recommended to power the modems off of 3.90V as any deviations outside of the modem's acceptable operating voltage range may irreparably damage the modem and void the warranty.

Some modems also support an extended operating voltage range of 3.20V to 4.50V or 3.0V to 5.5V. Extreme care must be taken when designing a system that utilizes the low

end of the operating voltage range to ensure that the system's power supply is robust enough to handle the modem's current spikes without dropping below the minimum allowable voltage.

If there is a voltage drop or overshoot that exceeds the limits of the extended operating voltage range, it may cause damage to the modem and void the modem's warranty. The extended operating voltage range should only be used with thoroughly tested power supply systems that have been shown to be able to handle the rigorous current demands of an LTE modem without falling out of the extended operating voltage range.

5.2.1 Power Supply design Guidelines

When designing the power supply for a Skywire modem it is recommended to adhere to the following design guidelines:

- For most applications, a switching power supply is recommended to supply power to the Skywire modem. Switching power supplies are able to rapidly respond to the sudden current demands of an LTE modem. To ensure compatibility with other Skywire modems, it is recommended to use a switching regulator capable of supporting up to 2A with a switching frequency greater than 500 KHz. Example designs using a switching DC/DC regulator can be found in the reference schematics in section 6.
- To reduce EMI from the switching regulator, it is important to follow the design guidelines from the switching regulators' manufacturer.
- Bypass ceramic capacitors (low ESR) with adequate capacity must be placed near the input to pin 1 (VCC) of the Skywire modem. It is recommended that the capacitor have a rated voltage of at least 2x the input voltage to the Skywire. A minimum of a 100 μ F & 0.1 μ F capacitor is recommended for all Skywire modems.
- The decoupling capacitors should be placed in line with the power trace with the smallest value capacitors closest to the modems VCC pin, followed by the larger capacitance capacitors. Example capacitor layouts are available in section 6.
- Power and ground connections to the modems socket and decoupling capacitors should not use any thermal reliefs.
- The PCB traces from the power regulator and the bypass capacitors must be wide enough to ensure that there is a low impedance power delivery circuit available to the modem. This ensures that no significant voltage drops occur. Try to keep the trace as short as possible. NimbeLink recommends the power trace on outer layers of 1 oz copper, to be at least 80 mils wide at its narrowest. This recommendation is for the VCC nets, and must also be implemented on the GND return paths.
- A dedicated ground plane is recommended.
- Power supply input cables should be kept away from noise sensitive lines, such as antennas.

5.3 Power Control

5.3.1 ON_OFF Signal

The ON_OFF signal on pin 20 is used to trigger the modem to turn on, and to turn the modem off. **Do not drive this pin high nor apply a pullup resistor, it should only be driven by an open collector or open drain signal.**

To conserve power, Skywire modem's cellular modules do not automatically startup when power is applied, except for the SVZM20 modem. The baseboard design must supply a means to assert a logic-low level on the ON_OFF pin. To initiate the startup procedure, tie ON_OFF to ground for the period specified in the modem's datasheet. Similarly, if the modem is currently running, the ON_OFF pin can be pulled low again for a period of time to initiate a power-down sequence, except for the SVZM20 modem. The timing for the ON_OFF signal will vary by modem, details on this signal are available in the datasheet for the modem you are working with.

Additionally, the module can be configured to automatically start when power is applied. This can be done by tying the ON_OFF signal to GND (either directly or through a 0 ohm pulldown resistor). However, doing so does run the risk of the modem attempting to boot before the input voltage to the modem is >3.20V. This could cause the modem to lock up. If lock up occurs, the nRESET pin should be asserted to force the modem to initiate a restart. Tying the modem's ON_OFF signal to ground to force an automatic boot at power up may also affect the modem's ability to shut down via AT commands.

For optimal control of the cellular modem, it is recommended that the system designer control the ON_OFF signal from their host platform using an open collector output or external discrete open collector transistor.

At the time of the writing of this document the ON_OFF pin on the SVZM20 modem has not yet been implemented by the modems underlying module vendor. When the SVZM20 modem is powered up it will automatically turn on. The shut down process for the modem must be initiated via AT command.

5.3.2 Shutdown

The modem should be shut down in a controlled manner, so as to gracefully disconnect it from the network. Failure to do so violates carrier requirements and could cause the modem to be blacklisted from the network. In rare events, failure to properly shut down the modem could render it inoperable due to firmware corruption.

To gracefully shut down the modem, the host system should do the following:

- Shut down the modem with the modem-specific AT command. This command will gracefully disconnect the modem from the network and shut down the modem. After this command is issued, the host system should cease any communications with the modem.
- Users should monitor the STATUS pin (as described in Section 3.5.2) or URC messages to ensure the modem has powered down.

- To ensure no communication lines are back powering the modem when shutdown, it is recommended to place those I/O lines in a High-Z state.
- Remove VREF (if VCC is being removed).
- Remove VCC.

In the event of main system power failure, the modem may need to be shut down faster than the AT command can manage. Some modems include a fast shutdown command to immediately power down the modem. This command should not be regularly used since it may not correctly detach from the cellular network.

5.4 nRESET Signal

In the event that the modem becomes unresponsive, use the ON_OFF signal to attempt to safely power cycle the modem. If that is unsuccessful in restoring the modem, pin 5 (nRESET) can be grounded to reset the modem. This pin should only be used as a last resort option in the event that the modem does not power cycle via the ON_OFF pin or via AT commands. **Do not drive this pin high or apply a pullup resistor. It should only be driven by an open collector or open drain signal.**

When pin 5 is grounded, the modem will cease all ongoing operations, and reset itself.

Please note: the modem will not detach itself from the network before resetting. Network providers request that a device gracefully detach from the network before shutting down. Accordingly, this functionality should only be used as an emergency reset when the modem is not responding to commands.

To reset the modem with the nRESET signal, tie the pin low for at least 150 ms, and then release. The signal is internally pulled up to the modem's internal 1.8V rail and should not have an external pullup. It should only be driven by an open collector or open drain output.

If the signal is unused, it can be left floating, but it is highly recommended that the signal be connected to the host system.

In high noise (high EMI) environments, we recommend designers place a 0.01-0.1 μ F capacitor on the nRESET line near the Skywire modem socket.

5.5 VREF

VREF is used as the reference signal for voltage level translators on the Skywire. The voltage on VREF should match the host processor's I/O voltage. VREF will draw less than 1mA when the modem is powered.

System designers should include a method of removing the voltage from VREF when the system is in Power Save Mode (PSM) or when the modem is powered down. One such method would be to power VREF from a GPIO or to have a P-CH MOSFET in the VREF signal path.

5.6 DTR/WAKE

Pin 9 is used as a Data Terminal Ready (DTR) and/or Wakeup input pin, depending on the modem. When used as a DTR pin it is a control signal for the modem's serial interface and can be used to cause the modem to disconnect from an active connection into command mode. Modems with low power modes may use this signal as control signal for entering/exiting those modes.

5.7 Status Monitoring

Pin 13 is used as a general status indicator. However, depending on the modem its functionality will vary. This pin is a 1.8V output from the modem that will go to a high state when the modem is powered on. Refer to the modem's datasheet for more information.

5.8 Ring Indicator

On NimbeLink's Cat M1 Skywire modems, the ADC pin has been replaced by the Ring Indicator pin. The Ring Indicator on these modems can be used to alert host processors of inbound network traffic and to alert the host when a modem URC (Unsolicited Result Code) has occurred. The Ring indicator may also be used as part of the modem's Power Save Mode (PSM) and is recommended to be connected if PSM will be used.

5.9 GPIOx

On most modems pins 18 & 19 are connected to 1.8V GPIO that are controlled by the underlying cellular module (on the SVZM20 modem these pins are reserved and should be not connected). These pins are usually general input/outputs, however some modems do also support I2C functionality on these pins. These GPIO can be used for a variety of functions including, but not limited to, reading I2C sensors, antenna switching, and power monitoring.

5.9.1 Power Monitoring with a modem's GPIO pin

GPIO pins on the modems can be configured to go high signal when the modem boots up, allowing for the pin to be used as a power monitor. To configure the pin please refer to the GPIO configuration command for the respective modem you are working with.

5.10 SIM Cards

Skywire modems are made to accept 3FF SIM cards and do not ship with a SIM card installed. OEMs are responsible for sourcing the SIM card to use with modem from their carrier. NimbeLink does stock SIM cards for Verizon, AT&T, T-Mobile, and other carriers through our distribution channels. For assistance sourcing SIM cards please reach out to NimbeLink's sales team at sales@nimbelink.com.

The NL-SW-LTE-QBG96 & NL-SW-LTE-TM1G Skywire modems include a soldered down Verizon SIM card on the modems circuit board and do not require an external 3FF SIM card.

5.11 ESD

Skywire modems are not protected against Electrostatic Discharge (ESD) in general. They are subject to ESD handling precautions that typically apply to ESD sensitive devices. Proper ESD handling and packaging procedures must be followed during the processing, handling, or operation of the modems.

6. Layout & Schematic Considerations

The following section contains general design guidelines that should be followed when integrating a Skywire into a host system. A checklist of all the Skywire modem guidelines is available [here](#). System integrators are strongly recommended to follow all the guidelines in the Skywire Hardware Design Checklist.

Example Schematics for the Skywire modem are available here:

- [NL-AB-BBCL Dev Kit Schematic](#)
- [NL-AB-RPI Dev Kit Schematic](#)

6.1 Layout Examples

The following are layout examples of good Skywire modem integrations.

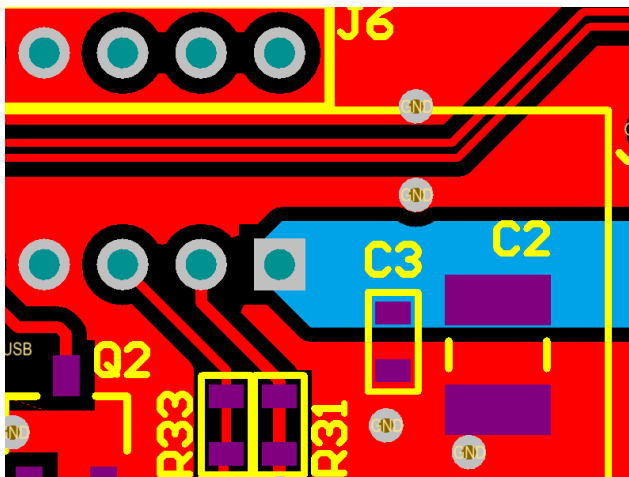

Figure 6.1.1

Figure 6.1.1 shows an example of the recommended method of placing the modems decoupling capacitors and connecting power to the Skywire modem. The +3.9V power rail, highlighted in blue, is a wide, low impedance trace that is directly connected to the modems VCC pin and decoupling capacitors C2 & C3. The decoupling capacitors C2 & C3 are arranged so that the smallest capacitance value capacitor (C2) is closest to the Skywire modems VCC input. All of the power and ground connections are directly connected to the associated pads, allowing for a low impedance connection.

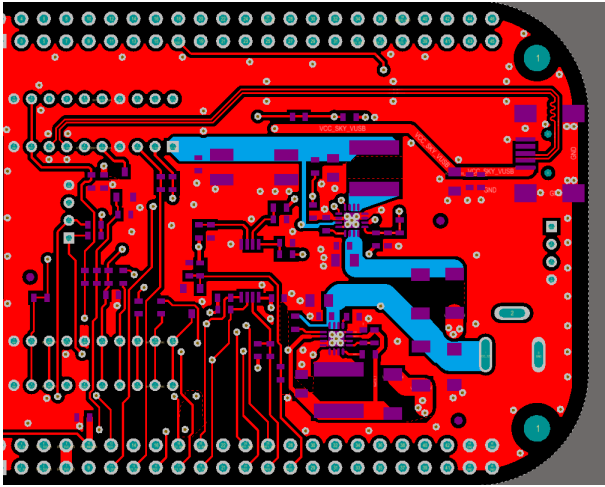

Figure 6.1.2

Figure 6.1.2 shows a low impedance power path, highlighted in blue. The power traces, from the systems power input to the modems VCC pin. All of the power traces leading to the modems VCC pin are wide, low impedance traces.

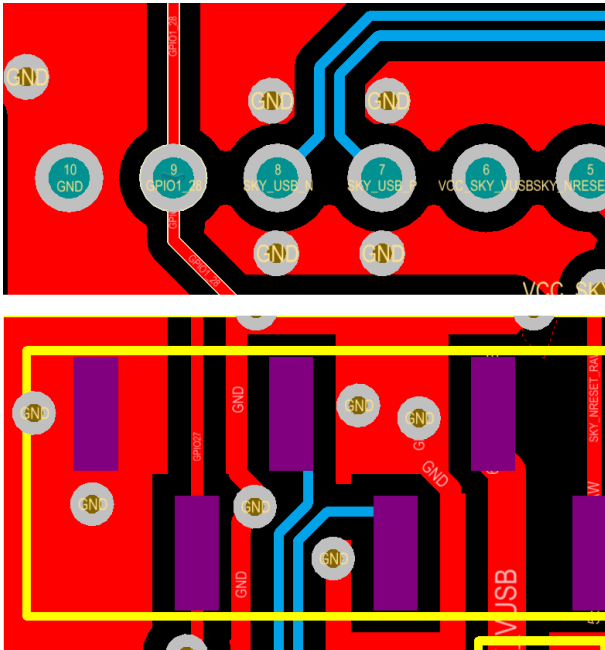

Figure 6.1.3

Figure 6.1.3 shows an example of USB signal breakouts for both through hole and SMT Skywire connections. As soon as the USB D+/- signals, highlighted in blue, exit the connectors they should be routed as an impedance matched 90 ohm differential pair. Additionally, proper Skywire GND pin grounding can be observed.

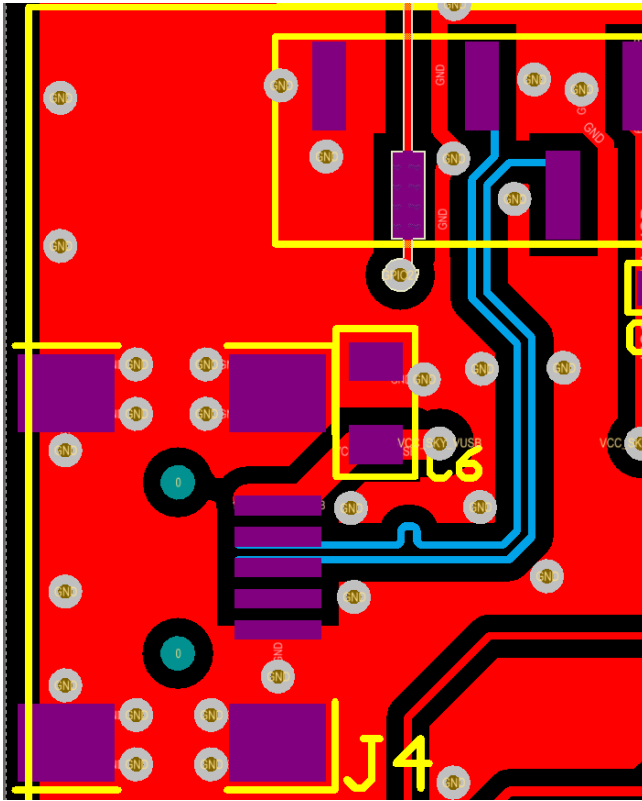
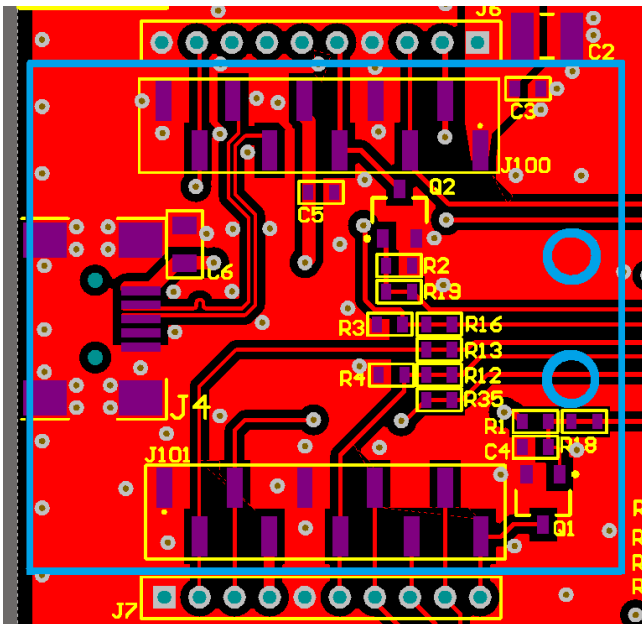

Figure 6.1.4 shows an example of a properly routed USB traces. Note that the traces, highlighted in blue, are immediately routed at 90 ohm differential pairs and are length matched.

Figure 6.1.4



To aid with the assembly process of the customers end product Nimbelink recommends that integrators include silkscreen markers on their PCB to indicate the modems outline and orientation when it is inserted. One such method to do this is to include indicators for where the UFL connectors should be aligned, as shown in figure 6.1.5, highlighted in blue.

Figure 6.1.5

7. Enclosure Considerations

Skywire modems are not conformal coated nor sealed in any way, and therefore must rely on their enclosure to protect them from harsh environments.

If the system is using an internal cellular antenna then the system integrator should confirm that the enclosure's material will not interfere with the antenna.

Any internal wiring inside the enclosure should be kept away from the modem, modem coaxial connections, and antennas as it may cause interference.

The Skywire modems do not have a locking mechanism built in to their socket. Therefore they rely on external mechanisms to hold it in place. When using an off the shelf enclosure designers may use a zip tie, glue, or other securing mechanism to hold the modem in place. For custom designed enclosures, NimbeLink recommends designing in a rib in the enclosure to ensure the modem stays seated in its socket. An example drawing is available at the link below.

- [Skywire Mechanical Retention Drawing](#)

8. Skywire Antenna Considerations

The Skywire modems have antenna independent certifications with the regulatory bodies and cellular carriers, so any antenna that meets the requirements in Section 10 can be used without additional certification steps.

The type of antenna that is used and its placement is critical in order to ensure a reliable cellular connection. This section will detail the different antenna connections on the Skywire modem and antennas' characteristics that users should look for in an antenna along with placement considerations that users should consider.

8.1 Skywire Antenna Connections

All Skywire modems have a primary cellular antenna connection labeled 'X1'. The primary antenna connection serves as both a receive and transmit antenna path. This connection must have an antenna connected to it in order for the modem to be able to connect to the network.

Higher speed CAT 1, CAT 3, and CAT 4 modems have a diversity antenna connection labeled 'X2'. The diversity antenna serves as a second receive-only antenna port for the modem, enabling the modem to have up to a 3dB improvement in the receive signal quality. For applications that will be used in an urban area this will significantly improve the modem's performance. To meet carrier certification requirements, the diversity antenna is required for CAT 3 & CAT 4 devices and is highly recommended for CAT 1 devices.

Some Skywire modems have built in GNSS subsystems that enable users to have cellular connectivity and GNSS location services in one package. On these modems the GNSS antenna port is labeled with 'X3' on the PCB's silkscreen. Skywire modems are designed to use an active GNSS antenna and will not typically work with passive GNSS antennas.

8.2 Antenna Considerations

Skywire modems must be used with antennas with a 50 ohm impedance. Skywire modems provide U.FL connectors for antenna connections. Most antennas will require an adapter cable, such as a U.FL to SMA cable, to connect from the modem to the antennas RF interface.

Ideally the modem's antenna will be placed near the modem to minimize the cable loss between the modem and the antenna. If this is not possible, use of low loss coaxial cable is required.

Antennas are designed to be used in very specific ways. Often times the way they are mounted in end devices will cause the antenna to detune, which will impact the performance of the system. OEMs will need to ensure that their antenna of choice is mounted in accordance with the antenna manufacturers guidelines. For instance, many

antennas are designed to be mounted to ABS plastic and will not operate correctly if mounted to metal.

Not all antennas are created equally and different products will often have different antenna requirements. When selecting an antenna, OEMs should consider the following:

- What bands or frequencies does the modem support?
- What is the antenna's efficiency at the desired operating frequencies?
- How will the antenna be attached to the modem?
- What additional requirements does the antenna have?

LTE antennas are designed to radiate at specific LTE frequencies. Some antennas might offer spectacular performance at one frequency, but lackluster performance at another. During the antenna selection process, OEMs must identify all of the frequencies that their modem will need to operate at and select an appropriate antenna that can handle those frequencies.

An often overlooked performance metric of an antenna is its efficiency at the frequencies of interest. Antenna efficiency measures how well the antenna will convert the RF signal from the modem into radiated power. OEMs should take into account that an antenna's efficiency is not the same across all the frequencies that the antenna supports. NimbeLink recommends that customers select antennas with an antenna efficiency of at least 50% in the frequencies of interest for optimal performance.

Many antennas require a substantial ground plane to operate correctly. These antennas use the system ground plane as the second half of the radiating structure. While these antennas can be traditionally smaller and more compact, the need for a larger ground plane may offset the size benefit. Another option is a ground plane independent antenna like a dipole. These antenna structures incorporate all radiating elements inside them so there is no concern about the size and shape of the end device's ground plane. The tradeoff is they are traditionally larger than the ground plane dependant type.

Most antennas are not manufactured to be mounted close to or directly on metal. The metal will detune the antenna, and block the desired RF signals. OEM's with applications needing to use an antenna on a metal surface will need to consult an antenna manufacturer to select the correct antenna for their product.

NimbeLink strongly recommends that OEMs work closely with their antenna vendor's engineering team to determine the appropriate antenna for their application.

9. System Verification

NimbeLink recommends that OEMs perform thorough device verification testing of their product before deploying production units. This will help ensure the host system can fully support the Skywire modem and will help reduce the likelihood for future board spins or product recalls.

The following verification tests are recommended:

9.1 Operational tests

- Power Cycle Behavior
 - OEMs should evaluate their board to ensure the modem power up and power down cycle is properly handled and their implementation will not damage the modem.
- Signal Quality
 - OEMs should check that the modem's signal quality (RSSI, RSRP, RSRQ) is within expected ranges. Poor signal quality may indicate a bad connection, power issue, or noise issue.
- Network Registration Check
 - The modem should be able to register on the network fairly quickly (<30 seconds) after it is booted. If the modem is not able to register OEMs should confirm that the antenna is connected to the primary antenna port & check the APN configuration.
- Throughput testing
 - OEMs should evaluate their system to ensure that the design is able to support sending their expected data payloads through the modem. If the modems throughput is not performing as expected there could be a design integration issue. Please note that cellular networks may limit the download and upload rates of the modem based on the modems data plan and current network conditions.

9.2 Stress Testing

- Power Testing
 - OEMs should test the modem's maximum power draw in their host system to ensure brownout conditions will not occur under poor signal conditions. To simulate poor signal conditions where the modem will draw high amount of power, OEMs should attenuate the modems RF signal using RF attenuators.
 - OEMs should attempt to continuously send large amounts of data through the modem in their host board to ensure that the host boards power supply is robust enough to keep the modem's input voltage stable under heavy load. This test will also evaluate the modems communications path signal integrity. If there is an issue in

the communications path or with the power supply OEMs will see data loss or lose communication with the modem during this test.

- **Signal Integrity Testing**
 - Applications that are using long signal runs between the modem and their host processor should check the modems communication signal paths for ringing.
 - Designs that interface into the modem's USB 2.0 interface should consider having a USB eye diagram test performed to ensure that the OEM's USB implementation is correct.
- **Mechanical**
 - Vibration & shock Testing
 - The Skywire modem relies on its enclosure and/or host system to ensure the modem stays properly seated in its socket. OEMs should perform vibration & drop tests to ensure that the modem, its RF connections, and SIM card are properly secured.

9.3 End of Line Testing

OEM may wish to do end of End of Line Testing during the manufacturing process for final products. The following tests are recommended for systems using the Skywire to ensure that the device is mounted correctly:

- **Check Modem Status**
 - Send AT commands to the modem to ensure the modem properly boots & responds to AT commands. If the modem does not respond to AT commands it may be improperly mounted.
- **Live Network Test**
 - Test the modems network connectivity by checking what networks it can see, its signal strength, and network registration. This will ensure it can see a network and register on it. If the modem can not register or connect to the network, check the following:
 - Confirm that the the cellular antenna connections are on the correct U.FL connectors.
 - Confirm that the SIM card is inserted and the modem can read the SIM.
 - Confirm that the SIM is active and that the modems APN is correctly configured.
 - Use AT commands to check the signal quality of the modem's connection to the tower. If the signal quality is low (RSSI<-90dB, RSRP<-100dB, or RSRQ<-10dB) then the modem may not be able to register on the network due to a poor connection. In the event of poor signal quality, try moving the antenna to a different location.

9.4 Steps Performed at NimbeLink Factory

Upon completing circuit board assembly and inspection, each Skywire modem goes through an electrical and functional test process. The following items are tested on every modem:

- SIM card is inserted into SIM connector.
- Modem is placed into test fixture designed for high volume manufacturing.
- Test fixture engages Primary and Secondary antenna U.FL connectors.
- Test fixture engages GNSS antenna U.FL connectors.
- Test fixture engages Skywire 20 pin interface.
- Power is applied to the Skywire and modem is booted.
- AT commands are issued over UART and USB paths to validate functionality.
 - SIM ICCID is read to validate SIM interface.
 - Cellular RSSI/RSRP/RSRQ is measured to validate RF paths.
 - GNSS receiver is turned on and sample to validate GNSS RF paths.
 - Modem registers onto local cellular carrier to validate modem functionality.
 - Module IMEI is read.
 - Module firmware version is read and compared against desired firmware.
 - Firmware update is performed if required.

10. Data Plans

All embedded cellular modems are meant to use M2M/IoT data plans and do not typically work on consumer data plans. These data plans will often require a specific M2M SIM that is not available at consumer cell phone stores. These requirements can make activating data plans for end customers a frustrating process. NimbeLink highly recommends that OEMs manage their customer data plans instead of leaving the process up to each of their end customers.

To enable NimbeLink's customers to rapidly develop and deploy their products NimbeLink has set up an online activations portal for Verizon, AT&T, and T-Mobile data plans. Details on NimbeLinks Cellular data plans can be found at the following links:

- [NimbeLink Cellular Data Plans](#)
- [NimbeLink Cellular Data Plans Activations Page](#)

11. Certification Considerations

11.1 FCC & IC Intentional Radiator

The Skywire modem includes a modular transmitter in licensed radio frequency bands and requires no additional FCC or IC intentional radiator testing as long as an antenna is selected that does not exceed the maximum gain limits provided in the datasheet and the product includes proper labeling as shown in the datasheet.

11.2 FCC Emissions

All products including those that include Skywire modems must meet FCC emissions requirements for their industry.

11.3 Colocation of Radio Systems

If a design includes more than one transmitting radio, the design may require additional intentional radiator testing. The FCC holds manufacturers responsible for compliance, but no longer require you to submit permissive changes to the FCC ID. Systems that do not simultaneously transmit and have independent antennas are not obligated to test further. Also systems with antennas placed greater than 9" apart and transmit simultaneously need no extra testing.

11.4 Carrier Specific

Skywire modems are end-device certified with cellular carriers and do not require any additional registration or certification efforts by the OEM. The certifications are also antenna independent, so there are no restrictions on antenna selection. However, we do provide recommended antennas in the datasheet for each product and also recommend you provide the highest quality antenna your device can use to ensure positive customer experience by users in the field.