

Skywire Global 4G LTE Cat M1, NB-IOT, 2G w/ GNSS Embedded Cellular Modem Datasheet

NimbeLink Corp

Updated: February 2020



© NimbeLink Corp. 2020. All rights reserved.

NimbeLink Corp. provides this documentation in support of its products for the internal use of its current and prospective customers. The publication of this document does not create any other right or license in any party to use any content contained in or referred to in this document and any modification or redistribution of this document is not permitted.

While efforts are made to ensure accuracy, typographical and other errors may exist in this document. NimbeLink reserves the right to modify or discontinue its products and to modify this and any other product documentation at any time.

All NimbeLink products are sold subject to its published Terms and Conditions, subject to any separate terms agreed with its customers. No warranty of any type is extended by publication of this documentation, including, but not limited to, implied warranties of merchantability, fitness for a particular purpose and non-infringement.

NimbeLink is a registered trademark, and Skywire is a registered trademark, of NimbeLink Corp. All trademarks, service marks and similar designations referenced in this document are the property of their respective owners.

Table of Contents

Table of Contents	2
Introduction	4
Scope	4
Contact Information	4
Orderable Part Numbers	4
Additional Resources	4
Product Overview	5
Block Diagram	5
Technical Specifications	6
Electrical Specifications	6
Absolute Maximum Ratings	6
Modem Pinout (J1, J2) and Recommended Operating Conditions	6
Module Pinout for Connectors J3, X1, X3	8
Typical Power Consumption	9
RF Specifications	11
Mechanical Specifications	12
Mechanical Characteristics	12
Mechanical Drawing	12
Mating Connectors	13
Device Placement	13
Environmental Specifications	13
Design Considerations	14
Power Supply Requirements	14
Power Supply Design Guidelines	15
Serial Communications	16
Serial UART Interface	16
USB Interface	16
VREF	17
Power Control	17
ON_OFF Signal	17
Power Monitoring	18
Shutdown	18
Firmware Updates Over the Air (FOTA)	19
Soldered-Down SIM	19
GNSS	20

GNSS Antenna Requirements	20
Active GNSS Antenna Control	21
GNSS Antenna Placement	21
Recommended Antennas	21
Cellular Antenna Requirements	22
Primary Antenna Requirements	22
Antenna Placement	23
Recommended Antennas	24
Skywire Reference Design	24
Mounting Guidelines	24
Board-to-Board Connectors Approach	24
Mechanical Retention	25
Solder to Board Connection	25
Regulatory information	26
Carrier Specific Certifications	26
Export Control Classification Number (ECCN)	26
RoHS Compliance	26
Interference statement	26
FCC & IC Compliance	26
Wireless Notice	27
Modification Statement	28
End Product Labeling Requirements	28
Document Version Information	29

1. Introduction

1.1 Scope

The aim of this document is to serve as a hardware reference datasheet for the NL-SW-LTE-QBG95 Skywire® modem family.

1.2 Contact Information

NimbeLink's goal is to make integrating the Skywire modem into your product as easy as possible. Please send any feedback, documentation requests, or technical support questions to Nimbelink's product support team at: product.support@nimbelink.com

For purchasing information, please visit the "Part Ordering Information" section on the modem's [product page](#). Any additional sales questions or requests for quotation can be directed to NimbeLink's sales team at: sales@nimbelink.com

1.3 Orderable Part Numbers

Orderable Device	Operating Temp.	4G LTE Bands	2G Bands	Cellular Networks
NL-SW-LTE-QBG95	-40 to +85°C	CAT M1 (LTE-FDD): B1, B2, B3, B4, B5, B8, B12, B13, B14, B18, B19, B20, B25, B26*, B27, B28, B66, B85 CAT-NB2 (LTE-FDD): B1, B2, B3, B4, B5, B8, B12, B13, B18, B19, B20, B25, B26*, B28, B66, B71, B85	EGPRS: GSM 850, GSM 900, DCS 1800, PCS 1900	AT&T, Orange, Telstra, Telus, Verizon, Vodafone, And more

Note: Band 26 support is under development by the cellular module manufacturer.

1.4 Additional Resources

- [Skywire® Global 4G LTE Cat M1 Embedded Modem Product Page](#)
- Skywire® Global 4G LTE Cat M1 AT Command Manual (Coming Soon)
- [Skywire® Global 4G LTE Cat M1 Application Notes](#)
- [Skywire NL-SWSDK User Manual](#)
- [Skywire Hardware Design Developers Guide](#)
- [Skywire Hardware Design Checklist](#)
- [Skywire Software Developers Guide](#)

1.5 Product Overview

The NL-SW-LTE-QBG95 Skywire embedded modem is purpose-designed for IoT applications, particularly those requiring location-based functionality. Based on the Quectel BG95-M3 module, it has full FCC, IC, and carrier end-device certifications, which can save users months of testing and tens of thousands of dollars in cost. Like all Skywire modems, the QBG95 is among the smallest embedded modems in the industry, and is compatible with a wide range of Skywire development kits and microprocessor shields, helping to accelerate product development and prototyping.

LTE Cat M1 modems have the lowest power requirements of any cellular modem type, making them ideal for battery operated, mobile, or off-grid applications. Depending on the application, they may be able to run for years unattended and without requiring a battery replacement or recharge.

1.6 Block Diagram

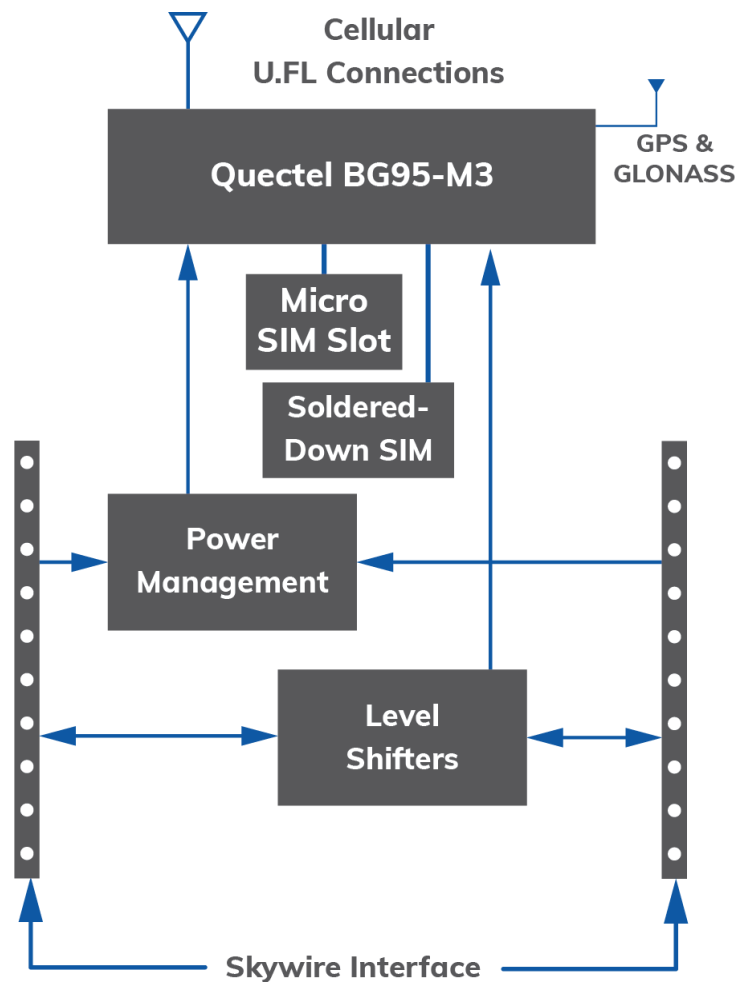

2. Technical Specifications

2.1 Electrical Specifications

2.1.1 Absolute Maximum Ratings

To avoid potential damage to the modem, ensure that all voltages applied to the modem pins do not fall outside of the ranges specified by the max and min ratings:

Parameter	Signal	Minimum Rating	Maximum Rating
Main Power Supply	VCC	-0.3V	6.0V
I/O Voltage Reference	VREF	-0.3V	6.5V
USB Supply Voltage	VUSB	-0.3V	5.5V
Digital I/O Pins	STATUS_1V8, GNSS_UART_TX, GNSS_UART_RX	-0.3V	2.09V

2.1.2 Modem Pinout (J1, J2) and Recommended Operating Conditions

The following table details the pinout of the NL-SW-LTE-QBG95 Skywire modem, and recommended ratings for the Skywire interface on connectors J1 and J2.

Pin	Name	Type	Description	Min	Typ.	Max	
1 (J1-1)	VCC	Input	Main power supply input. Must be implemented	3.4V	3.8V	4.3V	
2 (J1-2)	DOUT	Output	UART data out, I/O level tied to VREF. Must be implemented if USB is unused. Otherwise, leave unconnected if unused.	0V		VREF	
3 (J1-3)	DIN	Input	UART data in, I/O level tied to VREF. Must be implemented if USB is unused. Otherwise, leave unconnected if unused.	VREF Range	VIL		VIH
				1.65V to 1.95V	VREF x 0.35V		VREF x 0.65
				2.3V to 2.7V	0.7V		1.7V
				3.0V to 3.6V	0.8V		2V
				4.5V to 5.5V	VREF x 0.3V		VREF x 0.7

Pin	Name	Type	Description	Min	Typ.	Max
4 (J1-4)	GND	Input	Ground Pin. Must be implemented.		0V	
5 (J1-5)	nRESET	Input	Modem reset signal. Must be driven with an open-drain output and should never be driven high. Leave unconnected if unused.	VIL: GND to 0.45V		
6 (J1-6)	VUSB	Input	USB connection detection. Leave unconnected if the USB interface is unused.	3.0V	5.0V	5.25V
7 (J1-7)	USB_P	I/O	USB positive differential data signal. Requires differential impedance of 90Ω. Leave unconnected if the USB interface is unused.	Compliant with USB 2.0 standard specification.		
8 (J1-8)	USB_N	I/O	USB differential data bus (-) Requires differential impedance of 90Ω. Leave unconnected if the USB interface is unused.	Compliant with USB 2.0 standard specification.		
9 (J1-9)	DTR	Input	Data terminal ready signal (sleep mode control), tied to internal reference voltage of 1.8V. Leave unconnected if unused.	VIL: GND to 0.54V		VIH: 1.26V to 5.5V
10 (J1-10)	GND	Input	Ground Pin. Must be implemented.		0V	
11 (J2-1)	GND	Input	Ground Pin. Must be implemented.		0V	
12 (J2-2)	CTS	Output	Clear To Send hardware flow control signal. Leave unconnected if unused.	0V		VREF
13 (J2-3)	STATUS	Output	Indicates the current operation status of the BG95-M3 module. Driven high when the module is on. Leave unconnected if unused.	VOL: 0V to 0.45V		VOH: 1.35V to 1.8V

Pin	Name	Type	Description	Min	Typ.	Max
14 (J2-4)	VREF	Input	Voltage reference for offboard I/O signals. Must be implemented.	0V	1.8V or 3.3V	5.5V
15 (J2-5)	GND	Input	Ground Pin. Must be implemented.		0V	
16 (J2-6)	RTS	Input	Modem "Request to Send" hardware flow control input. It is not required to connect this signal.	VREF Range	VIL	VIH
				1.65V to 1.95V	VREF x 0.35V	VREF x 0.65
				2.3V to 2.7V	0.7V	1.7V
				3.0V to 3.6V	0.8V	2V
				4.5V to 5.5V	VREF x 0.3V	VREF x 0.7
17 (J2-7)	GNSS_UA RT_RXD	I/O	GPS UART RXD signal. Used to receive GPS data from the modem. Fixed 1.8V reference. Leave unconnected if unused.	VIL: -0.3V to 0.6V		VIH: 1.2V to 2.0V
18 (J2-8)	GNSS_UA RT_TXD	I/O	GPS UART TXD signal. Can be used to send AT commands to the modem. Leave unconnected if unused.	VOL: 0V to 0.45V		VOH: 1.35V to 1.8V
19 (J2-9)	RING	Output	Ring Indicator Output. Normally high, 120ms low pulse when URC present. Open Drain output, 1M pull-up to VREF on modem.	VOL 0 to 0.1V		VREF
20 (J2-10)	ON_OFF	Input	Modem ON/OFF signal. Must be driven with an open-drain output and should never be driven high. Must be implemented.	VIL: GND to 0.45V		1.5V

2.1.3 Module Pinout for Connectors J3, X1, X3

Connector Designator	Description	Connector Location
J3	Micro SIM Connector	Bottom Side of Modem
X1	Cellular Antenna Connection	Top Side of Modem
X3	GPS/GNSS Satellite Receiver	Top Side of Modem

2.1.4 Typical Power Consumption

The values contained in Section 2.1 .4 are provided as an example of typical current consumption behavior for NL-SW-LTE-QBG95 Skywires.

In customer applications, current consumption may vary, and is influenced by factors such as: signal quality, ambient temperature, battery/supply voltage, supply impedance, board capacity, and other factors.

Test	RSRQ (dBm)	RSRP (dBm)	Average Current (mA)	Average Peak Current (mA)	Average Charge (μAh)	Measurement Notes
Socket Dial on LTE-M Network, 0 dB of Attenuation	-48	-11	90.808	774.582	44.096	Supply Voltage: 3.8V Number of Tests: 5 Average Duration: 1.709 s Notes: Modem registered on the network prior to the test. Test consists of opening socket, HTTP POST, reading HTTP response, and closing socket.
Socket Dial on LTE-M Network, 20 dB of Attenuation	-71	-13	92.761	905.747	46.015	Supply Voltage: 3.8V Number of Tests: 5 Average Duration: 1.747 s Notes: Same as previous test.
Socket Dial on LTE-M Network, 40 dB of Attenuation	-88	-12	97.053	934.508	47.367	Supply Voltage: 3.8V Number of Tests: 5 Average Duration: 1.757 s Notes: Same as previous test.
Modem Boot	N/A	N/A	60.360	117.695	46.520	Supply Voltage: 3.8V Number of Tests: 5 Average Duration: 2.766 s Notes: Modem booted from powered-off state. Test concluded when "RDY" URC was received from modem.
Registered Idle	-40	-17	23.830	827.983	1.992 (mAh)	Supply Voltage: 3.8V Number of Tests: 1 Duration: 300 s Notes: Modem was booted and allowed to register on the network. 300 second measurement was taken while the modem was idling.

Test	RSRQ (dBm)	RSRP (dBm)	Average Current (mA)	Average Peak Current (mA)	Average Charge (μAh)	Measurement Notes
Unregistered Idle	N/A	N/A	9.592	73.194	801.154	Supply Voltage: 3.8V Number of Tests: 1 Duration: 300 s Notes: Modem booted and placed into "CFUN: 4" mode (unregistered state). 300 second measurement was taken while modem idled.
PSM						Coming Soon
eDRx						Coming Soon
Powered Off	N/A	N/A	8.217 (uA)	217.315 (uA)	683.376 (nAh)	Supply Voltage: 3.8V Number of Tests: 1 Duration: 300 s Notes: Modem powered off using the "AT+QPOWD" command. 300 second measurement was taken while the modem was in a powered-down state.
GPS Cold Start	N/A	N/A	76.954	700.975	813.136	Supply Voltage: 3.8V Number of Tests: 5 Average TTFF: 37.966 s Notes: Modem booted, and idle in an unregistered state. Measurement was started, then GPS was enabled. Measurement concluded when modem obtained a fix.
GPS Hot Start	N/A	N/A	77.817	122.300	1.622	Supply Voltage: 3.8V Number of Tests: 5 Average Duration: 0.094 s Notes: Modem booted, and idle in an unregistered state. GPS enabled and allowed to obtain location fix. Measurement started, then the location was queried with the "AT+QGPSLOC?" command. Measurement concluded when the modem responded with GPS data.

2.1.5 RF Specifications

Parameter		Value	
4G LTE Technology		4G Cat M1, 4G Cat NB2	
4G LTE TX output power		20dBm ± 2dB	
4G LTE RX Sensitivity	Band (LTE-FDD)	Cat M1/3GPP (dBm)	Cat NB2/3GPP (dBm)
	B1	-104.6/-102.3	-115/-107.5
	B2	-104.8/-100.3	-115/-107.5
	B3	-103.9/-99.3	-115/-107.5
	B4	-104.3/-102.3	-115/-107.5
	B5	-104.4/-100.8	-115/-107.5
	B8	-104.4/-99.8	-115/-107.5
	B12	-104.7/-99.3	-115/-107.5
	B13	-103.8/-99.3	-115/-107.5
	B14	-104.4/-99.3	Not Supported
	B18	-104.4/-102.3	-115/-107.5
	B19	-104.7/-102.3	-115/-107.5
	B20	-104.4/-99.8	-115/-107.5
	B25	-104.7/-100.3	-114/-107.5
	B26	-104.4/-100.3	-114/-107.5
	B27	-104.4/-100.8	Not Supported
	B28	-104.3/-100.8	-115/-107.5
	B66	-104.4/-101.8	-115/-107.5
B71	Not Supported	-115/-107.5	
B85	-104.9/-99.3	-115/-107.5	
GSM RX Sensitivity	GSM850/EGSM900	-107/-102	
	DCS1800/PCS1900	-107/-102	
Peak Uplink and Downlink Speeds	Connection Type	Downlink	Uplink
	4G LTE Cat M1	300 Kbps	375 Kbps
	4G LTE Cat NB2	32 Kbps	70 Kbps
	EGPRS	296 Kbps	236.8 Kbps

2.2 Mechanical Specifications

2.2.1 Mechanical Characteristics

Parameter	Typical	Unit
Dimensions (excluding pin height, for solder to board applications)	1.334 x 1.140 x 0.243 [33.9 x 29.0 x 6.2]	inches [mm]
Dimensions (including pin height, for board to board connector applications)	1.334 x 1.140 x 0.400 [33.9 x 29.0 x 10.2]	inches [mm]
Weight	0.282 [8]	ounces [grams]
Connector Insertion/Removal	hundreds	Cycles

2.2.2 Mechanical Drawing

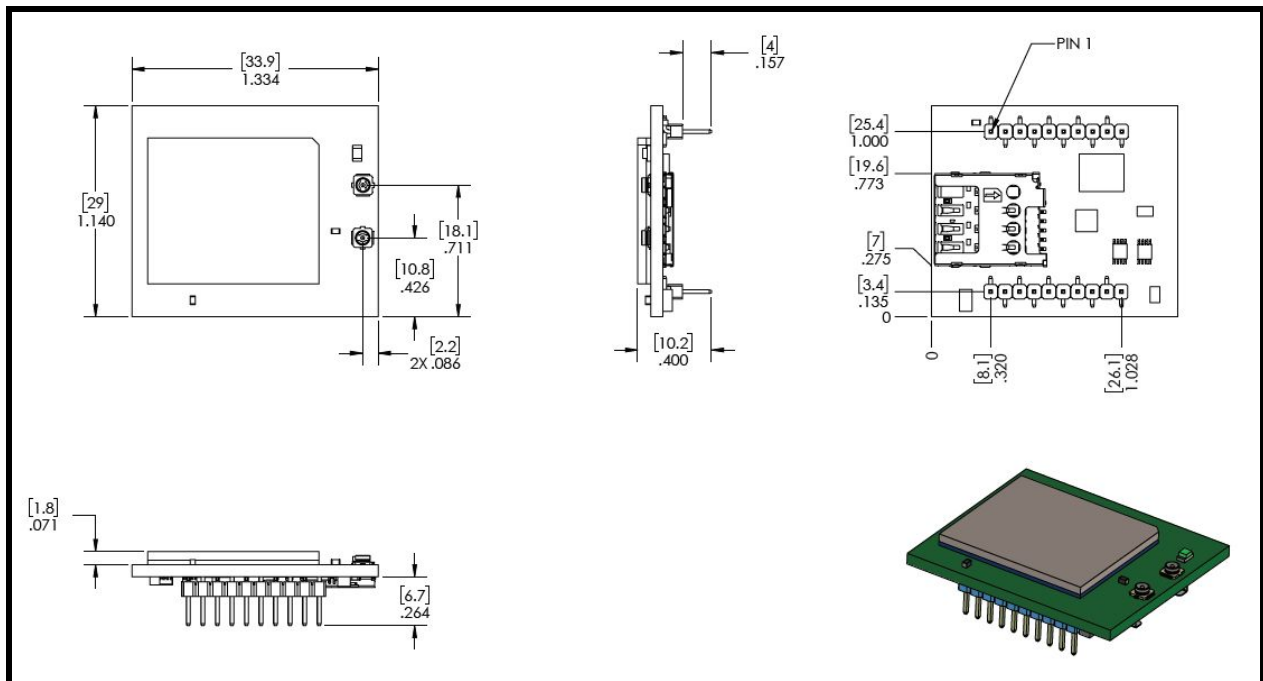

Note: Units are in inches and [mm].

2.2.3 Mating Connectors

Connector Designator	Manufacturer	Populated on Modem	Recommended Mate	Mate Manufacturer
J1, J2	Pinrex	222-96-10GBE1	950510-6102-AR	3M
			Acceptable Alternate: NPPN101BFCN-RC	Sullins Connector Solutions
J3	Molex	786463001	Micro SIM 3FF Size	Micro SIM Card
X1, X3	Hirose	U.FL-R-SMT(10)	CAB.011	Taoglas

2.2.4 Device Placement

⚠ Make sure the Skywire is installed in the correct orientation in the host board. Failure to do so will damage the device and void the warranty.

2.2.5 Environmental Specifications

Parameter	Min	Typical	Max	Unit	Note
Operating Temperature	-40	25	+85	°C	
Storage Temperature	-40	25	+90	°C	
Operating Humidity	20		90	%	Non-condensing
Operating Temperature	-40	25	+85	°C	

3. Design Considerations

The following sections detail various design considerations that system designers should follow when designing the Skywire modem into their system. NimbeLink offers free schematic and layout design reviews for customers integrating a Skywire modem into their design. For more details please reach out to Nimbelink product support team at product.support@nimbelink.com.

3.1 Power Supply Requirements

NL-SW-LTE-QBG95 modems will regularly consume high amounts of current on their main power supply (Pin 1, VCC) input, up to 1.2A during LTE-M1 transmits and receives, 2G GSM connections will repeatedly hit 2A during transmissions. In order to maintain compatibility with other 4G LTE Skywire modems, the baseboard power supply should be designed to support peak currents of at least 2 Amps. A 0.1 uF & 100uF low ESR ceramic capacitor should be placed on the baseboard near the VCC pin of the Skywire to ensure ample energy is available, with a low inductance path to the VCC pin.

Parameter	Value
Nominal Supply Voltage	3.8V
Operating Voltage Range	3.4V to 4.3V

NL-SW-LTE-QBG95 modems have an operating voltage range of 3.4V to 4.3V, with a recommended input voltage of 3.8V. Ensure that the voltage on the VCC pin never falls below 3.4V in order to prevent potential damage to the modem. The power supply must be able to handle the rigorous current demands of an LTE modem without falling outside of the operating voltage range.

If there is a voltage drop or overshoot that exceeds the limits of the operating voltage range, it may cause damage to the modem and void the modem's warranty.

3.1.1 Power Supply Design Guidelines

When designing the power supply for a Skywire modem it is recommended to adhere to the following design guidelines:

- For most applications, a switching power supply is recommended to supply power to the Skywire modem. This is because switching power supplies are able to rapidly respond to the sudden current demands of an LTE modem. To ensure compatibility with other Skywire modems, it is recommended to use a switching regulator capable of supporting up to 2A. Example designs using a switching DC/DC regulator can be found in the reference schematics below.
- To reduce EMI from the switching regulator, it is important to follow the design guidelines from the device manufacturer.
- Bypass ceramic capacitors (low ESR) with adequate capacity must be placed near the input to pin 1 (VCC) of the Skywire modem. It is recommended that the capacitor has a rated voltage of at least 2x the input voltage to the Skywire.
- A minimum of a 100 uF & 0.1uF capacitor is recommended for all Skywire modems. The 0.1uF capacitor should be placed as close as possible to pin 1 of the Skywire modem, followed by the 100 µF capacitor.
- The PCB traces from the power regulator and the bypass capacitors must be at least 80 mils to ensure that there is a low impedance power delivery circuit available to the modem. This ensures that no significant voltage drops occur. Try to keep the trace as short as possible.
- A dedicated ground plane is recommended.
- Power supply input cables should be kept away from noise sensitive lines, such as antennas.

NimbeLink offers multiple power supply reference designs in order to assist customers with their designs at no extra charge. Two of the designs are linked to below:

[NL-AB-BBCL Reference Schematic](#)

[NL-SWDK Reference Schematic](#)

Nimbelink highly recommends prototyping with a Skywire Development kit as opposed to a breadboard, which will not work with a Skywire modem. Please refer to the following application note, which explains this incompatibility in more detail:

[Prototyping with Cellular Modems and Modules](#)

3.2 Serial Communications

The NL-SW-LTE-QBG95 modem has two communication paths: serial (UART) and USB. The serial UART interface is targeted for applications using lower speed 8/16/32 bit microcontrollers that do not have a USB interface or easily available USB interface drivers. The USB interface for the modem is meant for use by higher end systems with a native USB interface controller or operating system (Single board computers, Linux/Windows).

For designs that are only using the serial UART interface, NimbeLink recommends designers include test points or a non-populated USB connector footprint in their designs. This allows access to the modem's USB interface to enable easy debugging and firmware updates.

3.2.1 Serial UART Interface

All Skywire modems support a serial UART interface with transmit and receive on pins 2 (DOUT) and 3 (DIN). On the NL-SW-LTE-QBG95 modem, the baud rate defaults to 115200 Baud 8N1. If a different baud rate is required, it can be changed with the **AT+IPR** command as defined in the AT command manual. The modem also supports RTS/CTS flow control on pins 12 (CTS) and 16 (RTS).

By default, the modem does have flow control enabled. To modify the flow control setting, please see the **AT+IFC** command in the AT command manual. It is recommended that any designs using the serial UART interface connect the RTS/CTS flow control lines to the host microcontroller and enable them in their application.

3.2.2 USB Interface

The NL-SW-LTE-QBG95 modem supports a USB 2.0 interface on pins 6 (VUSB), 7 (USB_P), and 8 (USB_N). Systems connecting to the modem's USB interface must observe proper design practices for connecting to a high speed USB device including, but not limited to, the following:

- The USB D± traces should be routed as a 90 ohm impedance differential pair.
- The USB D± traces should be length matched as closely as possible.
- USB trace lengths should be minimized.
- USB differential pairs should be carefully routed to ensure they have a continuous return path beneath the traces. Do not route differential pairs over splits in ground or power planes.
- If the USB signals will be used off-board, ESD protection should be implemented near the off-board connector.

Pin 6 is the VUSB detection pin that the modem uses to detect if a USB host controller has been connected to the modem. This pin has an internal pulldown and must have a voltage between 3.0V and 5.5V applied to it in order to activate the USB interface. The VUSB pin will draw less than 5mA when connected. VUSB must be disconnected or asserted to ground before activating Power Saving Mode.

3.3 VREF

The VREF signal drives the input voltage side of an onboard buffer which converts external I/O voltage from the VREF range to the 1.8V range in order to drive the onboard Quectel BG95 module. System designers should connect the reference voltage of their system to this pin. The VREF signal will draw less than 1mA when the modem is powered.

To enable low power operation, system designers should include a method of removing the voltage from VREF when the system is in Power Save Mode (PSM). One such method would be to power VREF from a GPIO or to have a P-CH MOSFET in the VREF signal path.

3.4 nRESET Signal

In the event that the modem becomes unresponsive, pin 5 (nRESET) can be grounded to unconditionally shut down the modem. When pin 5 is grounded, the modem will cease all ongoing operations, and reset itself. Please note: the modem will not detach itself from the network before resetting.

Network providers request that a device gracefully detach from the network before shutting down. Accordingly, this functionality should only be used as an emergency reset when the modem is not responding to commands.

To unconditionally shut down the modem with the nRESET signal, tie the pin low for at least 2 seconds, and then release. The signal is internally pulled up to the modem's internal 1.8V rail.

If the signal is unused, it can be left floating, but it is highly recommended that the signal be connected to the host system. If the signal is used, it should be driven with an open collector output from the host system or a discrete open collector transistor.

In high noise (high EMI) environments, we recommend designers place a 0.01-0.1 uF capacitor on the nRESET line near the J1 connector.

3.5 Power Control

3.5.1 ON_OFF Signal

The ON_OFF signal on pin 20 is used to trigger the modem to turn on, and to turn the modem off. Please note: do not power this pin nor apply a pullup resistor.

To conserve power, the onboard cellular module does not automatically startup when power is applied. Therefore, the baseboard design must supply a means to assert a logic-low level on the ON_OFF pin. To initiate the startup procedure, tie ON_OFF to ground for 500-1000 ms. This pin should not be permanently attached to ground.

If the modem is currently running, the ON_OFF pin can be pulled low for 650-1500 ms to initiate a power-down sequence.

The ON_OFF signal should be driven with an open collector output or with an open collector transistor. The signal is internally pulled up and should not be driven high, as doing so may prevent the modem from booting.

For optimal control of the cellular modem, it is recommended that the system designer control the ON_OFF signal from their host platform using an open collector output or external discrete open collector transistor.

3.5.2 Power Monitoring

Applications can check to see if the modem has powered up by reading the logic state on pin 13 (STATUS). When the Quectel BG95 module is powered up and running, pin 13 will be driven high to 1.8 V. When the module is not running, this pin will be logic level low. The STATUS pin will go high approximately 2.1 seconds after the ON_OFF pin is asserted. Power should not be removed from the modem until the STATUS pin has gone low during the shutdown procedure.

3.5.3 Shutdown

The modem should be shut down in a controlled manner, so as to gracefully disconnect it from the network. Failure to do so violates carrier requirements. In rare events, failure to properly shut down the modem could render the modem inoperable due to firmware corruption.

To gracefully shut down the modem, the host system should do the following:

- Shut down the modem with the **AT+QPOWD=1** command. This command will gracefully disconnect the modem from the network and shut down the modem. This process will take no longer than a couple of seconds. After this command is issued, the host system should cease any communications with the modem.
- If power is to be cut from the modem, ensure that the host system is not back powering the modem through any of the modem's I/O lines.
- Users should monitor that the STATUS pin has gone low prior to removing power (as described in Section 3.5.2) to ensure the modem has powered down.
- Remove VREF (if VCC is being removed).
- Remove VCC.

In the event of power failure, the modem may need to be shut down faster than the **AT+QPOWD=1** command can manage. To immediately power down the modem in the event of power failure, the **AT+QPOWD=0** command can be used to force a fast shutdown.

3.6 Network Status Monitoring

In order to conserve power, the NL-SW-LTE-QBG95 does not have a status LED. It is recommended to monitor the modem's network status using AT commands and the serial interface.

3.7 Firmware Updates Over the Air (FOTA)

LTE networks are constantly being updated, improved, and enhanced with new features. As a result, carriers are making frequent network changes. Most will not negatively affect devices connected to those networks, but occasionally an update will prevent an unprepared device from reconnecting to the network permanently.

To account for these future changes, FOTA (Firmware over the Air) capability is being added to cellular modules by each manufacturer. Accordingly, NimbeLink supports this functionality in the entire Skywire family of embedded modems. As such, it is highly recommended that designers implement provisions to accommodate FOTA processes.

Failure to accommodate FOTA processes may result in interruptions in cellular connectivity in the event of network changes. If a device can no longer access the network, FOTA cannot be used to remedy the problem. The only way to recover functionality is to physically update the device firmware.

FOTA Instructions are available by contacting NimbeLink's product support team at product.support@nimbelink.com.

3.8 Soldered-Down SIM

The NL-SW-LTE-QBG95 modem has the ability to select between a soldered-down SIM or a removable SIM inserted into the SIM card slot on the modem.

By default, the modem is configured to attempt to use the SIM card slot. However, users can select which SIM the modem is using by controlling the onboard SIM selection switch with AT commands. Whenever SIM selection is switched, the modem's RF system will need to be toggled with the AT+CFUN command.

To configure the modem to use the soldered down SIM issue the following commands to the modem in the order they appear below:

```
AT+CFUN=0
```

```
AT+QCFG="gpio",1,26,1,0,0,1
```

```
AT+QCFG="gpio",3,26,1,1
```

```
AT+CFUN=1
```

To configure the modem to use the SIM in the SIM card socket issue the following commands to the modem in the order they appear below:

AT+CFUN=0

AT+QCFG="gpio",1,26,1,0,0,1

AT+QCFG="gpio",3,26,0,1

AT+CFUN=1

Note: GPIO states will persist after reset, and the above AT commands will not need to be reissued each time the modem is powered on. Firmware updates may overwrite saved GPIO states, however.

3.9 GNSS

The onboard Quectel BG95 module includes a fully integrated global navigation satellite system solution that supports Gen9 VT of Qualcomm (GPS, GLONASS, BeiDou/Compass, Galileo and QZSS). The BG95 has an embedded low-noise amplifier (LNA) that is utilized by the GNSS system. The modem supports both passive GNSS antennas and active antennas with a gain, at the modems RF connector, of <20dB.

3.9.1 GNSS Antenna Requirements

Item	Value
Frequency Range	1559 – 1609 MHz
Impedance	50 Ω
Polarization	RHCP or linear
VSWR	< 2 (Typ.)
Passive Antenna Gain	> 0 dBi
Active Antenna Noise Figure	< 1.5 dB
Active Antenna Gain	> 0 dBi
Active Antenna Embedded LNA Gain	< 17 dB
Technology	Frequency
GPS / QZSS	1575.42 \pm 1.023 MHz
GLONASS	1597.5 – 1605.8 MHz
Galileo	1575.42 \pm 2.046 MHz
BeiDou	1561.098 \pm 2.046 MHz

3.9.2 Active GNSS Antenna Control

A 3.3VDC, 100 mA source is available on the modem to bias the GPS line in order to power the modem. Control of the GNSS power source is done via GPIO64 on the modem. To conserve power, the GNSS power is off by default.

To turn on the DC power to the GNSS antenna, and save it in this state across power off, issue the following commands to the modem:

```
AT+QCFG="gpio",1,64,1,0,0,1
```

```
AT+QCFG="gpio",3,64,1,1
```

To turn off the DC power to the GNSS antenna, and save this state after power off, issue the following commands to the modem:

```
AT+QCFG="gpio",1,64,1,0,0,1
```

```
AT+QCFG="gpio",3,64,0,1
```

Note: GPIO states will persist after reset, and the above AT commands will not need to be reissued each time the modem is powered on. Firmware updates may overwrite saved GPIO states, however.

3.9.3 GNSS Antenna Placement

- The antenna must be installed according to the antenna manufacturer's instructions in order to obtain the maximum performance of the GNSS receiver.
- The antenna location must be evaluated carefully if operating in conjunction with any other antenna or transmitter.
- The antenna must not be installed inside metal cases or near any obstacle that may degrade features like antenna lobes and gain.
- Keep the antenna and the antenna cabling away from any power supply lines, noisy EM devices, and wireless RF lines.

3.9.4 Recommended Antennas

Type	Manufacturer	Part Number
GPS/GALILEO Antenna, Internal ¹	Taoglas	AP.17E.07.0064A
GPS/GALILEO Antenna, External ¹	Taoglas	AA.108.301111

Note 1: U.FL to SMA adapter required.

3.10 Cellular Antenna Requirements

NL-SW-LTE-QBG95 modems support one primary cellular antenna connection for RX & TX communication via the X1 connector on the top of the modem. The X1 connector is a U.FL connector. Many antennas will require the use of a U.FL to SMA cable, such as the Taoglas CAB.011.

3.10.1 Primary Antenna Requirements

Depending on the frequency band(s) provided by the network operator, the customer shall use the most suitable antenna for that/those band(s):

Band	Uplink (MHz)	Downlink (MHz)
B1	1920 – 1980	2110 – 2170
B2, PCS1900	1850 – 1910	1930 – 1990
B3, DCS1800	1710 – 1785	1805 – 1880
B4	1710 – 1755	2110 – 2155
B5, GSM850	824 – 849	869 – 894
B8, EGSM900	880 – 915	925 – 960
B12	699 – 716	729 – 746
B13	777 – 787	746 – 756
B14	788 – 798	758 – 768
B18	815 – 830	860 – 875
B19	830 – 845	875 – 890
B20	832 – 862	791 – 821
B25	1850 – 1915	1930 – 1995
B26	814 – 849	859 – 894
B27	807 – 824	852 – 869
B28	703 – 748	758 – 803
B66	1710 – 1780	2110 – 2180
B71	663 – 698	617 – 652
B85	698 – 716	728 – 746

Note: B14 and B27 support LTE-M operation only. B71 supports LTE-NB2 only. B66 is currently under development by the cellular module manufacturer.

Specification	Value
VSWR	≤ 2 (Typ.)
Efficiency	$> 30\%$
Max Input Power	50 W
Input Impedance	50 Ω
Cable Insertion Loss (B5, B8, B12, B13, B14, B18, B19, B20, B26, B27, B28, B71, B85, GSM850, GSM900)	< 1 dB
Cable Insertion Loss (B1, B2, B3, B4, B25, B66, DCS1800, PCS1900)	< 1.5 dB

Note: Any antennas used with the modem will need to comply with the Wireless Notice detailed in Section 5.7.

3.10.2 Antenna Placement

The modem's cellular antenna placement will directly affect the modem's performance. It is vital that system designers carefully consider the placement of the antenna and follow all of the guidelines & specifications set by the antenna manufacturer. The following guidelines are general recommendations for antenna installation:

- Make sure the antenna has an impedance of 50 ohms.
- Keep the antenna cable as short as possible.
- The antenna must not be installed inside a metal enclosure, nor near metal objects unless specified by the antenna manufacturer.
- The antenna must be installed according to the manufacturer's instructions.
- Antenna gain must not exceed the values indicated in the regulatory requirements.
- Antenna integration should optimize antenna efficiency. Antennas are recommended to have $>50\%$ efficiency on all frequency bands.
- Additional FCC/IC testing may be required for applications where the antenna is located closer than 20 CM from the body.
- If the device antenna is located farther than 20cm from the human body and there are no co-located transmitter, the Quectel FCC/IC approvals can be re-used by the end product
- Antenna should not be mounted near noisy EM devices.

3.10.3 Recommended Antennas

Type	Manufacturer	Part Number
Internal Cellular Antenna	Taoglas	FXUB65.07.0180C
External Cellular Antenna ¹	Taoglas	TG.30.8113

Note 1: U.FL to SMA adapter required.

3.11 Skywire Reference Design

NimbeLink offers free reference schematic and layout files as examples of how to integrate Skywire modems into various systems. Schematics, design files, gerber files, and tutorials for a variety of different systems can be found on the [Skywire Development Tools webpage](#).

4. Mounting Guidelines

Skywire embedded cellular modems support multiple connection methods. The two primary methods are board-to-board connectors and soldering directly to the baseboard.

4.1 Board-to-Board Connectors Approach

The Skywire interface calls for two 10-pin, 2mm pitch, female receptacles spaced 22 mm apart. There are many connector manufacturers that can be used. Below is one readily available product:

Manufacturer: Sullins Connector Solutions, **Part Number:** NPPN101BFCN-RC

Typical part drawing and footprint information for the NPPN101BFCN-RC connector:

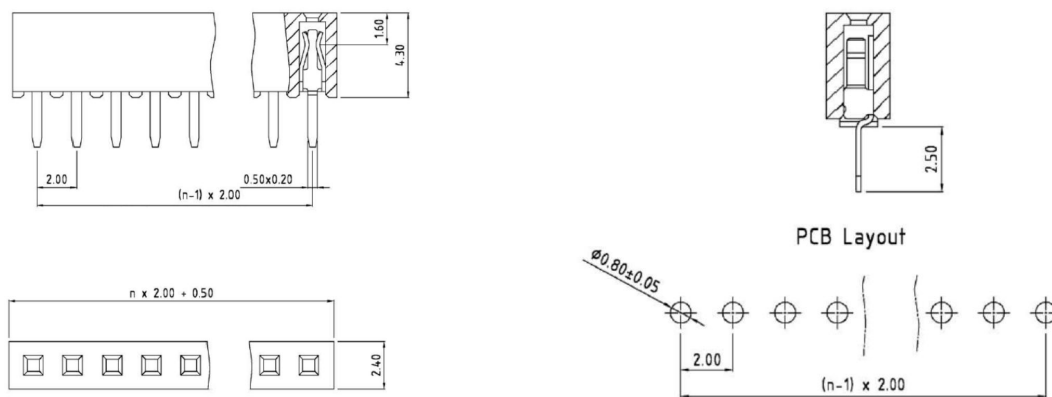

When using the recommended connector, ensure that any baseboard components placed under the Skywire (between the baseboard header pin connectors) are no taller than 4 mm. However, please note that the maximum component height may change based on the chosen baseboard connector.

4.1.1 Mechanical Retention

Certain applications where the modem is mounted on the host board using the connector approach detailed in section 4.1 may need to mechanically secure the Skywire modem & its SIM card in order to prevent the modem from vibrating out of the mating connectors. Skywire modems do not have any dedicated attachment points for securing to the host board, however it can easily be secured by one of the following methods:

- Zip ties
- Foam tape mounted on the Skywire to press against the enclosure
 - Note: User must ensure that foam tape does not compress the shielding can on the modem.
- Mechanical retention of the modem & SIM by the enclosure ([example](#))
- Solder the Skywire to the host board (as described in Section 4.2)

4.2 Solder to Board Connection

Alternatively, Skywires can be soldered directly to a PCB. The PCB should be designed with two rows of ten 0.8mm plated through holes spaced 2mm apart. See the figure below for the recommended footprint.

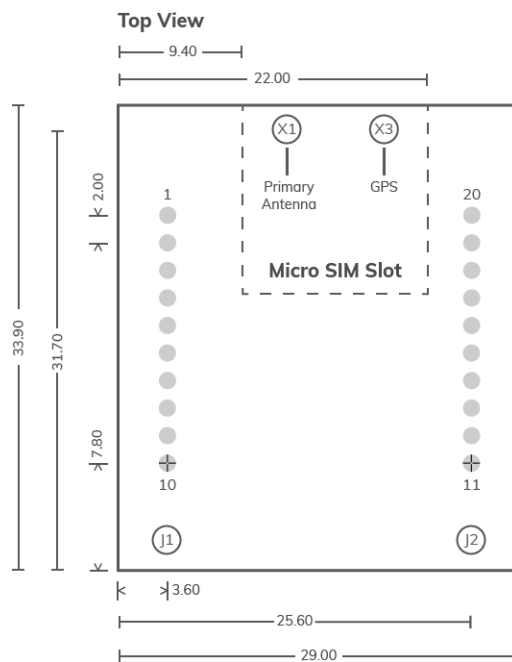

Note: All measurements are in millimeters. U.FL connectors X1 and X3 are on the top side of the board. Micro SIM card slot J3 is on the bottom of the board.

When using soldering directly to a PCB, ensure that any baseboard components placed under the Skywire (between the baseboard header pin connectors) are no taller than 0.5 mm.

5. Regulatory information

5.1 Carrier Specific Certifications

NL-SW-LTE-QBG95: Verizon ODI (**In Progress**), PTCRB (**In Progress**), AT&T (**In Progress**), GCF (**In Progress**), Telus (**In Progress**), Orange (**In Progress**)

5.2 Export Control Classification Number (ECCN)

ECCNs are five character alphanumeric designations used on the Commerce Control List (CCL) to identify dual-use items for export control purposes. An ECCN categorizes items based on the nature of the product, i.e. type of commodity, software, or technology and its respective technical parameters.

ECCN for All Skywire Modems: 5A992.c

5.3 Harmonized Tariff Schedule Code

HTS Code: 8517.62.0010

5.4 RoHS Compliance

The NL-SW-LTE-QBG95 modem family complies with the RoHS (Restriction of Hazardous Substances) directive of the European Union, EU Directive 2011/65/EU.

5.5 Interference statement

This device complies with Part 15 of the FCC Rules and Industry Canada licence-exempt RSS standards. Operation is subject to the following two conditions: (1) This device may not cause harmful interferences, and (2) this device must accept any interference received, including interference that may cause undesired operation.

5.6 FCC & IC Compliance

If the modem's antenna is located farther than 20cm from the human body and there are no adjacent transmitters, the FCC/IC approvals of the on-board Quectel BG95 cellular module can be reused by the end product.

Should the modems antenna be mounted closer than 20cm from the human body or if there are adjacent transmitters, additional FCC/IC testing may be required for the end product.

NL-SW-LTE-QBG95 modems make use of the on-board Quectel module's FCC & IC identification numbers.

Orderable Device	FCC ID	IC ID
NL-SW-LTE-QBG95	XMR201910BG95M3	10224A-2019BG95M3

The FCC certificate is available at the following link by searching for the FCCID listed above:

<https://www.fcc.gov/oet/ea/fccid>

The IC ID certificate is available at the following link by searching for the IC ID listed above:

<https://sms-sgs.ic.gc.ca/equipmentSearch/searchRadioEquipments?execution=e1s1&lang=en>

5.7 Wireless Notice

In order to maintain FCC/IC radiation exposure limits set forth for an uncontrolled environment alongside carrier specific certifications the antennas cannot exceed the maximum gain levels listed here:

Band	Max Antenna Gain
GSM 850	8.571 dB
GSM 1900	10.030 dB
Band 2	11.000 dB
Band 4	8.000 dB
Band 5	12.541 dB
Band 12	11.798 dB
Band 13	12.214 dB
Band 14	12.272 dB
Band 25	11.000 dB
Band 26	12.541 dB
Band 66	8.000 dB
Band 71	11.687 dB
Band 85	11.798 dB

5.8 Modification Statement

Nimbelink has not approved any changes or modifications to this device by the user. Any changes or modifications could void the user's authorization to operate the equipment.

5.9 End Product Labeling Requirements

End products utilizing NL-SW-LTE-QBG95 modems should be labeled with the following information:

Device Uses Approved Radio: NL-SW-LTE-QBG95

Contains FCC ID: XMR201910BG95M3

Contains IC: 10224A-2019BG95M3

This device complies with Part 15 of the FCC Rules and Industry Canada licence-exempt RSS standards. Operation is subject to the following two conditions: (1) This device may not cause harmful interferences, and (2) this device must accept any interference received, including interference that may cause undesired operation.

6. Document Version Information

Revision	Author	Description	Date
1	SDR	Initial document release.	02/25/20