

# Skywire 4G LTE Cat 1 WW Embedded Cellular Modem Datasheet

NimbeLink Corp

Updated: March 2022

**PRELIMINARY VERSION**



© NimbeLink Corp. 2022. All rights reserved.

NimbeLink Corp. provides this documentation in support of its products for the internal use of its current and prospective customers. The publication of this document does not create any other right or license in any party to use any content contained in or referred to in this document and any modification or redistribution of this document is not permitted.

While efforts are made to ensure accuracy, typographical and other errors may exist in this document. NimbeLink reserves the right to modify or discontinue its products and to modify this and any other product documentation at any time.

All NimbeLink products are sold subject to its published Terms and Conditions, subject to any separate terms agreed with its customers. No warranty of any type is extended by publication of this documentation, including, but not limited to, implied warranties of merchantability, fitness for a particular purpose and non-infringement.

NimbeLink is a registered trademark, and Skywire is a registered trademark, of NimbeLink Corp. All trademarks, service marks and similar designations referenced in this document are the property of their respective owners.

# PRELIMINARY VERSION

## Table of Contents

Table of Contents	2
1. Introduction	5
1.1 Scope	5
1.2 Contact Information	5
1.3 Orderable Part Numbers	5
1.4 Additional Resources	5
1.5 Product Overview	6
2. Technical Specifications	6
2.1 Block Diagram	6
2.2 Electrical Specifications	7
2.2.1 Absolute Maximum and Minimum Ratings	7
2.2.2 Module Pinout for Connectors J1 and J2	7
2.2.3 Module Pinout for Connectors X1, X2, X3, J3	10
2.2.4 Typical Power Consumption	10
Coming Soon	10
2.3 RF Specifications	11
2.3.1 Maximum RF Output Power	11
2.3.2 RX Sensitivity	11
2.3.3 4G LTE Uplink and Downlink Speeds	11 <a href="#">C</a>
2.4 Mechanical Characteristics	12
2.4.1 Mechanical Drawing	13
2.4.2 Mating Connectors	13
2.4.3 Device Placement	14
2.4.4 Environmental Specifications	14
3. Design Considerations	15
3.1 Power Supply Design	15
3.1.1 Power Supply Requirements	15
3.2 Serial Communications	17
3.2.1 Serial UART Interface	17
3.2.2 USB Interface	18

# PRELIMINARY VERSION

3.3	VREF	18
3.4	nRESET	18
3.5	Power Control	19
3.5.1	ON_OFF Signal	19
3.5.2	Shutdown	20
3.5.2.1	Hardware Shutdown	21
3.5.2.2	Software Shutdown	21
3.6	ON/nSLEEP	22
3.6.1	Power Status Monitoring	22
3.6.2	Network Status Monitoring	22
3.7	Firmware Updates Over the Air (FOTA)	23
3.8	Soldered-Down Verizon SIM	23
3.8.1	Enabling the Soldered-Down Verizon SIM	23
3.8.2	Swapping Between SIM Interfaces During Operation	24
3.8.3	Disabling the Soldered-Down Verizon SIM Interface	24
3.9	Dual-Image Firmware Information	25
3.9.1	Overview	25
3.9.2	AT#FWSWITCH Command Syntax	25
3.9.3	Selecting the AT&T Image	26
3.9.4	Selecting the Verizon Image	26
3.10	GNSS	26
3.10.1	GNSS Antenna Requirements	27
3.10.2	Active GNSS Antenna Control	27
3.11	Cellular Antenna Requirements	28
3.11.1	Primary Antenna Requirements	28
3.11.2	Diversity Antenna Requirements	29
3.11.3	Antenna Placement	29
3.11.4	Recommended Antennas	30
3.12	Skywire Reference Design	30
4.	Mounting Guidelines	31
4.1	Board-to-Board Connectors Approach	31
4.1.1	Mechanical Retention	31

# PRELIMINARY VERSION

4.2	Solder to Board Connection	32
5.	Regulatory Information	33
5.1	FCC & IC Compliance	33
5.2	Regulatory Certifications	33
5.3	Carrier Specific Certifications	33
5.4	Export Control Classification Number (ECCN)	33
5.5	Harmonized Tariff Schedule Code	34
5.6	Interference Statement	34
5.7	Wireless Notice	34
5.8	Modification Statement	34
5.9	End Product Labeling Requirements	34
6.	Document Version Information	36

# PRELIMINARY VERSION

## 1. Introduction

### 1.1 Scope

This document serves as the hardware datasheet for the NL-SW-LTE-TC1WWG Skywire® modem. This document is updated often, please be sure to download the latest version from NimbeLink's website.

### 1.2 Contact Information

NimbeLink's goal is to make integrating Skywire modems into end-user applications as easy as possible. Please send any feedback, documentation requests, or technical support questions to NimbeLink's product support team at:

[product.support@nimbelink.com](mailto:product.support@nimbelink.com)

For purchasing information, please visit the "Part Ordering Information" section on the modem's [product page](#). Any additional sales questions or requests for quotation can be directed to NimbeLink's sales team at:

[sales@nimbelink.com](mailto:sales@nimbelink.com)

### 1.3 Orderable Part Numbers

Orderable Device	Operating Temperature	4G LTE Bands	Fallback
NL-SW-LTE-TC1WWG	-40 °C to +85 °C	LTE-FDD: B1, B2, B3, B4, B5, B7, B8, B12, B13, B14, B19, B20, B26, B28	3G HSPA+: B1, B2, B4, B5, B8, B19
			2G: B2, B3, B5, B8

### 1.4 Additional Resources

- [Skywire® 4G LTE CAT 4 NA Embedded Modem Product Page](#)
- [Skywire® 4G LTE CAT 1 NA Embedded Modem Product Page](#)
- [Skywire® TCxNAG AT Command Manual](#)
- [Skywire® TCxNAG Application Notes](#)
- [Skywire® TCxNAG 3D Model \(STEP\)](#)
- [NL-SWSDK User Manual](#)
- [Skywire Hardware Design Developers Guide](#)
- [Skywire Hardware Design Checklist](#)
- [Skywire Software Developers Guide](#)

# PRELIMINARY VERSION

## 1.5 Product Overview

NimbeLink, a global leader in embedded cellular modem technology and asset tracking solutions, has introduced the Skywire® 4G LTE CAT 1 WW modem. This Skywire modem leverages Category 1 technology. The NL-SW-LTE-TC1WWG is ideal for delivering fast reliable cellular connectivity to products with applications worldwide.

The modem supports GNSS, dual SIMs, a single SKU for both AT&T and Verizon networks, integrated TCP/IP stacks, and is AT&T's FirstNet (Band 14) capable.

## 2. Technical Specifications

### 2.1 Block Diagram

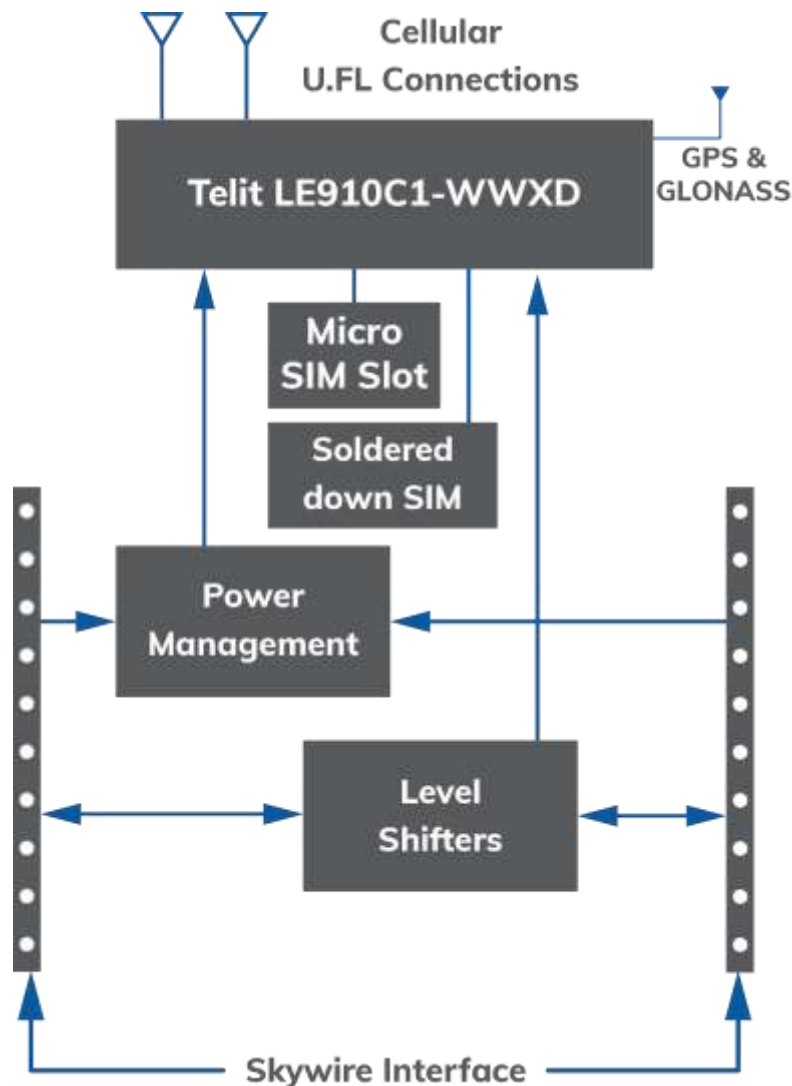

# PRELIMINARY VERSION

## 2.2 Electrical Specifications

### 2.2.1 Absolute Maximum and Minimum Ratings

To avoid potential damage to the modem, ensure that all voltages applied to the pins listed below do not fall outside of the ranges specified by the maximum and minimum ratings:

Parameter	Skywire Pin(s)	Min. Rating	Max. Rating
Main Power Supply <sup>1</sup>	VCC	3.4V	4.2V
Main Power Supply Ripple Voltage	VCC		30mV
I/O Voltage Reference	VREF	1.8V	5.5V
1.8V Referenced Signals	GPIO1, GPIO2, ON_OFF, nRESET	0 V	1.8V
VREF Referenced Signals	DIN, DOUT, DTR, RING, CTS, RTS	0 V	5.5V

1. Transient voltage drooping can occur on the VCC rail during normal modem operation. In order to prevent damage to the modem, transient voltage drops must not fall below 3.1V.

### 2.2.2 Module Pinout for Connectors J1 and J2

The following table details the pinout of the NL-SW-LTE-TC1WWG Skywire modem, and recommended ratings for the Skywire interface on connectors J1 and J2. More details and design requirements for these pins are documented in [Section 3](#).

Pin	Name	Direction	Description	Min	Typ.	Max
1 (J1-1)	VCC	Input	Main Power Supply Pin	3.4V	3.8V	4.2V
2 (J1-2)	DOUT	Output	UART data out, I/O level tied to VREF, internally pulled up to VREF.	0V		VREF
3 (J1-3)	DIN	Input	UART data in, I/O level tied to VREF	VREF Range	VIL	VIH
				1.65V to 1.95V	VREF x 0.35V	VREF x 0.65
				2.3V to 2.7V	0.7V	1.7V
				3.0V to 3.6V	0.8V	2V
4.5V to 5.5V	VREF x 0.3V	VREF x 0.7				

# PRELIMINARY VERSION

4 (J1-4)	GND	Input	Ground Pin			0V	
Pin	Name	Direction	Description		Min	Typ.	Max
5 (J1-5)	nRESET	Input	Reset signal for the LE910Cx cellular module, active low, drive with an open collector transistor. See <a href="#">Section 3.4</a> for additional requirements.	VIL	0V		0.6V
				VIH	1.25V		1.8V
6 (J1-6)	VUSB	Input	USB connection detection		2.5V	5.0V	5.5V
7 (J1-7)	USB_P	I/O	USB differential data bus (+) Requires differential impedance of 90Ω.		Compliant with USB 2.0 standard specification.		
8 (J1-8)	USB_N	I/O	USB differential data bus (-) Requires differential impedance of 90Ω.		Compliant with USB 2.0 standard specification.		
9 (J1-9)	DTR	Input	Data terminal ready (sleep mode control), tied to internal reference voltage of 1.8V	VIL	0V		0.63V
				VIH	1.17V		5.5V
10 (J1-10)	GND	Input	Ground Pin			0V	
11 (J2-1)	GND	Input	Ground Pin			0V	
12 (J2-2)	CTS	Output	Modem "Clear to Send" hardware flow control output, open drain assertion, internally pulled up to VREF.	VREF Range	VIL		VIH
				1.65V to 1.95V	VREF x 0.35V		VREF x 0.65
				2.3V to 2.7V	0.7V		1.7V
				3.0V to 3.6V	0.8V		2V
			4.5V to 5.5V	VREF x 0.3V		VREF x 0.7	



# PRELIMINARY VERSION

13 (J2-3)	ON/nSLEEP	Output	Modem status pin. See <a href="#">Section 3.6</a> for further information.		0V		1.8V
14 (J2-4)	VREF	Input	Voltage reference for offboard I/O signals.		1.65V	1.8V or 3.3V	5.5V
Pin	Name	Direction	Description		Min	Typ.	Max
15 (J2-5)	GND	Input	Ground Pin			0V	
16 (J2-6)	RTS	Input	Modem "Request to Send" hardware flow control input	VREF Range	VIL		VIH
				1.65V to 1.95V	VREF x 0.35V		VREF x 0.65
				2.3V to 2.7V	0.7V		1.7V
				3.0V to 3.6V	0.8V		2V
				4.5V to 5.5V	VREF x 0.3V		VREF x 0.7
17 (J2-7)	GPIO_3	I/O	Modem GPIO pin. 2-16 mA drive strength.	VIL	0V		0.6V
				VIH	1.25V		1.8V
				VOL	0V		0.45V
				VOH	1.4V		1.8V
18 (J2-8)	GPIO_2	I/O	Modem GPIO pin. 2-16 mA drive strength.	VIL	0V		0.6V
				VIH	1.25V		1.8V
				VOL	0V		0.45V
				VOH	1.4V		1.8V
19 (J2-9)	RING	Output	Modem Ring indicator pin. Open drain output, pulled up to VREF on Skywire. Pulled low when a new modem URC is available.		0V		VREF
20 (J2-10)	ON_OFF	Input	Modem On/Off signal, active low, drive with an open collector transistor. See <a href="#">Section 3.5</a> for additional requirements.	VIL	0V		0.2V
				VOH	0.7V		0.9V

Additional information on the Skywires pinout is available in Section 3.

# PRELIMINARY VERSION

## 2.2.3 Module Pinout for Connectors X1, X2, X3, J3

Connector Designator	Description	Connector Location
X1	Primary Cellular Antenna Connector	Top Side of Modem
X2	Diversity Cellular Antenna Connector	Top Side of Modem
X3	GPS / GNSS Antenna Connector	Bottom Side of Modem
J3	Micro SIM Connector	Bottom Side of Modem

## 2.2.4 Typical Power Consumption

The values contained in Section 2.2.4 are provided as an example of typical current consumption behavior for NL-SW-LTE-TC1WWG Skywires. In customer applications, current consumption may vary, and is influenced by factors such as: signal quality, ambient temperature, battery/supply voltage, baseboard design, and other factors.

**Coming Soon**

# PRELIMINARY VERSION

## 2.3 RF Specifications

### 2.3.1 Maximum RF Output Power

Available Cellular Technologies and Max TX Power	
4G LTE Technology	4G LTE CAT 1
4G LTE TX Output Power	23 ± 0.5 dBm
3G Technology	HSPA+
3G TX Output Power	23.5 ± 0.5 dBm

### 2.3.2 RX Sensitivity

Available Cellular Technologies and RX Sensitivity	
4G	-102.0 dBm (@ 5 MHz BW)
3G	-112.0 dBm (@ 5 MHz BW)

### 2.3.3 4G LTE Uplink and Downlink Speeds

4G LTE Peak Uplink and Downlink Speeds	
Uplink	5 Mbps
Downlink	10 Mbps

# PRELIMINARY VERSION

## 2.4 Mechanical Characteristics

Parameter	Typical	Unit
Dimensions	29.85 x 34.4 x 10.5	mm
	1.18 x 1.35 x 0.41	Inches
Weight	8	Grams
Connector Insertion/Removal	hundreds	Cycles

# PRELIMINARY VERSION

## 2.4.1 Mechanical Drawing

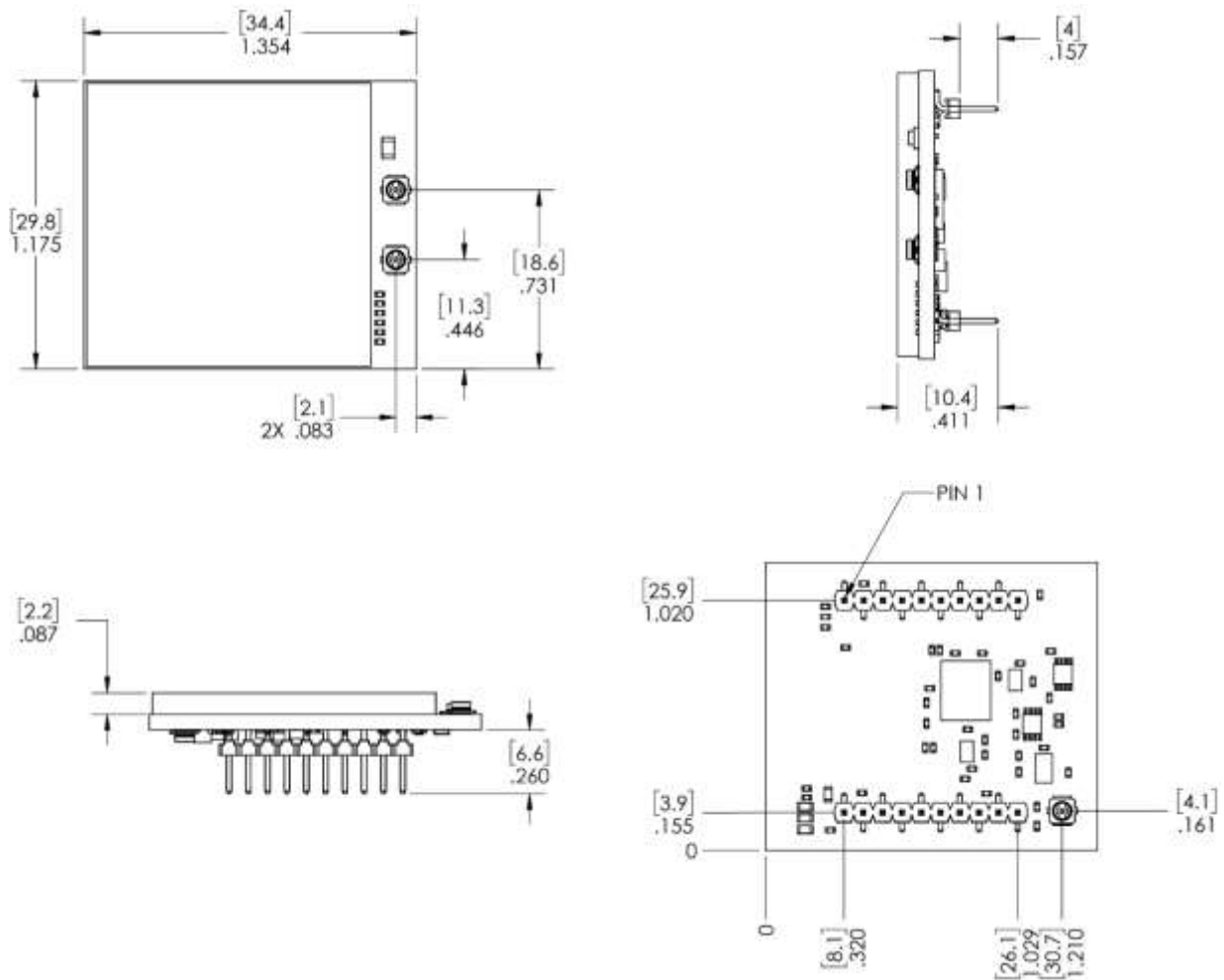

## 2.4.2 Mating Connectors

Connector Designator	Manufacturer	Populated on Skywire	Recommended Mate	Mate Manufacturer
J1, J2	3M	951110-2530-AR-PR	950510-6102-AR	3M
			NPPN101BFCN-RC	Sullins Connector Solutions
J3	Molex	786463001	Micro SIM 3FF Size	Micro SIM Card

# PRELIMINARY VERSION

X1, X2	Hirose	U.FL-R-SMT(10)	CAB.011	Taoglas
--------	--------	----------------	---------	---------

## 2.4.3 Device Placement

**⚠ Make sure the Skywire is installed in the correct orientation in your host board. Failure to do so will damage the device and void the warranty.**

## 2.4.4 Environmental Specifications

Parameter	Min	Typical	Max	Unit	Note
Operating Temperature	-40	+25	+85	°C	
Storage Temperature	-40	+25	+90	°C	
Operating Humidity	20		90	%	Non-condensing

# PRELIMINARY VERSION

## 3. Design Considerations

Section 3 describes important considerations that system designers should follow when utilizing a Skywire modem in a new or existing design.

NimbeLink offers free schematic and layout design reviews for customers integrating Skywire modems into their designs. Contact the following email for information:

[product.support@nimbelink.com](mailto:product.support@nimbelink.com).

To aid with customer design efforts NimbeLink has released a Skywire Hardware Developers Guide and a Design Checklist. These supplemental documents contain design guidelines and suggestions for customers designing Skywire modems into their hardware platforms. NimbeLink strongly suggests reviewing your hardware platform against these documents to ensure proper modem integration.

- [Skywire Hardware Developers Guide](#)
- [Skywire Hardware Design Checklist](#)

### 3.1 Power Supply Design

[Section 3.1](#) contains information regarding proper power supply design for users who are designing their own baseboard for a Skywire modem. In order to ensure proper modem operation and prevent potential damage, it is crucial to follow each of the requirements listed in this section.

#### 3.1.1 Power Supply Requirements

The NL-SW-LTE-TC1WWG Skywire has a normal operating voltage range of 3.40V to 4.20V, with a recommended input voltage of 3.80V. This modem will regularly consume high amounts of current on its main power supply inputs (Pin 1, VCC) and must have a well designed power supply that can support peak transient currents up to 2 Amps.

Parameter	Symbol	Min	Typ	Max	Unit
Operating Voltage Range	VCC	3.4	3.8	4.2	V
Current Consumption*	I <sub>vcc</sub>	-	400	2000	mA

\*Current consumption values depend on network configuration and are not under the modems control.

Designers must ensure that the supply voltage does not drop outside of the normal operating range at all times during modem operation. Failure to do so may cause the modem to brownout, which can cause permanent damage to the modem and void the modem's warranty.

# PRELIMINARY VERSION

When designing the power supply for a Skywire modem it is recommended to adhere to the following design guidelines:

- Use a DC-DC switching power supply that is capable of supplying up to 2A of current to the Skywire.
  - Switching power supplies are able to rapidly respond to the sudden current demands of an LTE modem.
  - It is recommended to use a regulator with an output voltage of 3.8V.
  - To reduce EMI from the switching regulator, follow the manufacturer design guidelines closely.
- Place a minimum of a 0.1  $\mu\text{F}$  low ESR ceramic capacitor and 100  $\mu\text{F}$  low ESR ceramic capacitor close to the VCC pin of the Skywire.
  - The 0.1  $\mu\text{F}$  capacitor should be placed as close as possible to the VCC pin of the Skywire followed by the 100  $\mu\text{F}$  capacitor.
  - The capacitors should be rated to at least twice the output voltage of the switching regulator.
  - See the reference schematics below for example power supply circuits.
- Ensure that there is a low impedance power path from the baseboard power supply to the VCC pin of the Skywire.
  - Use at least an 80 mil trace width for the power supply trace to the VCC pin. However, the wider the trace, the better.
    - An increased trace width will lower the inductance of the trace, improving the ability of the power supply to meet the transient current spikes of up to 2A during cellular network activity.
- Use a dedicated ground plane on the baseboard.
- Power supply input cables should be kept away from noise sensitive signal lines, such as antennas or USB traces.

NimbeLink offers multiple reference designs in order to assist customers with their designs at no charge. Two of the designs are linked to below:

## **NL-AB-BBCL Reference Schematic:**

[https://nimbelink.com/Documentation/Development\\_Kits/NL-AB-BBCL/20057s\\_NL-AB-BBCL\\_SCH.PDF](https://nimbelink.com/Documentation/Development_Kits/NL-AB-BBCL/20057s_NL-AB-BBCL_SCH.PDF)

## **NL-SWDK Reference Schematic:**



# PRELIMINARY VERSION

[https://nimbelink.com/Documentation/Development\\_Kits/NL-SWDK/20002\\_NL-SWDK\\_Schematic.pdf](https://nimbelink.com/Documentation/Development_Kits/NL-SWDK/20002_NL-SWDK_Schematic.pdf)

While prototyping with the modem, it is recommended to use a Skywire development kit, as opposed to a breadboard. Please refer to the following application note on why breadboards might cause problems and how to fix them:

## **Prototyping with Cellular Modems and Modules:**

[https://nimbelink.com/Documentation/Skywire/1001619\\_Breadboard\\_WhitePaper.pdf](https://nimbelink.com/Documentation/Skywire/1001619_Breadboard_WhitePaper.pdf)

## **3.2 Serial Communications**

The NL-SW-LTE-TC1WWG modem has two communication paths: serial (UART) and USB. The serial UART interface is targeted for applications using lower speed 8/16/32 bit microcontrollers that do not have a USB interface or easily-available USB interface drivers.

The USB interface for the modem is meant to be used by higher-end systems with a native USB interface controller or operating system, like single-board computers running Linux or Windows.

For designs that are only using the serial UART interface, NimbeLink recommends that including test points or a non-populated USB connector footprint in the design. This allows optional access to the modem's USB interface, which enables easy debugging and firmware updates.

### **3.2.1 Serial UART Interface**

All Skywire modems support a serial UART interface with transmit and receive on pins 2 (DOUT) and 3 (DIN), respectively.

On NL-SW-LTE-TC1WWG modems, the baud rate defaults to 115200 Baud 8N1. If a different baud rate is required, it can be changed with the "AT+IPR" command, as defined in the AT command manual. The syntax of the "AT+IPR" command is as follows:

**AT+IPR=<rate>**

Where "<rate>" is any supported baud rate listed in the AT command manual.

The modem also supports hardware flow control (RTS/CTS) on pins 12 (CTS) and 16 (RTS). By default, the modem does have flow control enabled.

To modify the flow control setting, see the "AT&K" command from the AT command manual. The syntax of the "AT&K" command is as follows:

**AT&K<x>**

Where "<x>" is replaced with either "0" to disable flow control, or "3" to enable flow control.

# PRELIMINARY VERSION

It is recommended that any designs using the serial UART interface connect the RTS/CTS flow control lines to the host microcontroller and enable them in their application.

## 3.2.2 USB Interface

The NL-SW-LTE-TC1WWG Skywire modem supports a USB 2.0 interface on pins 6 (VUSB), 7 (USB\_P), and 8 (USB\_N).

Systems connecting to the modem's USB interface must observe proper design practices for connecting to a high speed USB device including, but not limited to:

- The USB D $\pm$  traces should be routed as a 90 ohm impedance differential pair.
- The USB D $\pm$  traces should be length matched.
- USB trace lengths should be minimized.
  - USB differential pairs should be carefully routed to ensure they have a continuous return path beneath the traces. Do not route differential pairs over splits in ground or power planes.
  - If the USB signals will be used off-board, ESD protection should be implemented near the off-board connector.

Pin 6 (VUSB) is the pin that the modem uses to detect if a USB host controller has been connected to the modem. This pin has an internal pulldown and must have a voltage between 2.5V and 5.5V applied to it in order to activate the USB interface. The VUSB pin will draw less than 5mA when connected.

## 3.3 VREF

The VREF signal (pin J2-4) drives the input voltage side of an on-board buffer which converts external I/O voltage from the VREF range to the 1.8V range in order to drive the onboard cellular module.

System designers should connect the reference voltage of their system to this pin. The VREF signal will typically draw less than 5mA when the modem is powered, however this will depend on the host system's serial interface configuration.

If the baseboard powers down the modem at any time, it should also concurrently remove the reference voltage from the VREF pin.

## 3.4 nRESET

In the event that the modem becomes unresponsive, pin 5 (nRESET) can be grounded to unconditionally shut down the modem. When pin 5 is grounded, the modem will cease all ongoing operations and unconditionally shut down. The modem will need the ON\_OFF signal applied again to power on after a nRESET condition.

# PRELIMINARY VERSION

Users can monitor the ON/nSLEEP pin to determine if the modem has powered down.

In most cases, network providers request that a device gracefully detach from the network before shutting down. Repeated use of the nRESET pin violates this request. As such, the nRESET pin should only be used as a last resort when the modem is not responding to AT commands.

Repeated failure to gracefully detach from the network during shutdown may result in the device being blacklisted from the network for a period of time, or indefinitely.

The nRESET signal is an active low signal. The signal is internally pulled up to the modem's internal 1.8V rail. Do not apply a voltage to this pin other than connecting it to ground.

To unconditionally shut down the modem with the nRESET signal, assert a logic-low level on nRESET using an open-drain or open-collector circuit for at least 200 ms, and then release.

If the signal is unused, it can be left floating, however, it is highly recommended that the signal be connected to the host system.

In high noise (high EMI) environments, NimbeLink recommends that designers place a 0.01  $\mu$ F - 0.1  $\mu$ F capacitor on the nRESET line near the J1 connector of the Skywire.

## 3.5 Power Control

### 3.5.1 ON\_OFF Signal

The ON\_OFF signal on pin 20 is used to trigger the modem to turn on and off. Do not power this pin nor apply a pullup resistor. Doing so may prevent the modem from booting, or may cause damage to the modem.

This signal is internally pulled up; user's will typically see around 800 mV on the signal's output. The maximum current draw for this pin is 0.1mA.

To conserve power, the on-board cellular module does not automatically boot when power is applied. Therefore, the baseboard design must supply a means to assert a logic-low level on the ON\_OFF pin using an open-drain or open-collector circuit. An example circuit is shown in the image below.

To initiate the startup procedure, tie ON\_OFF to ground for 1<x<2 seconds. The modem will take approximately 20 seconds to turn on and be ready for AT commands.

# PRELIMINARY VERSION

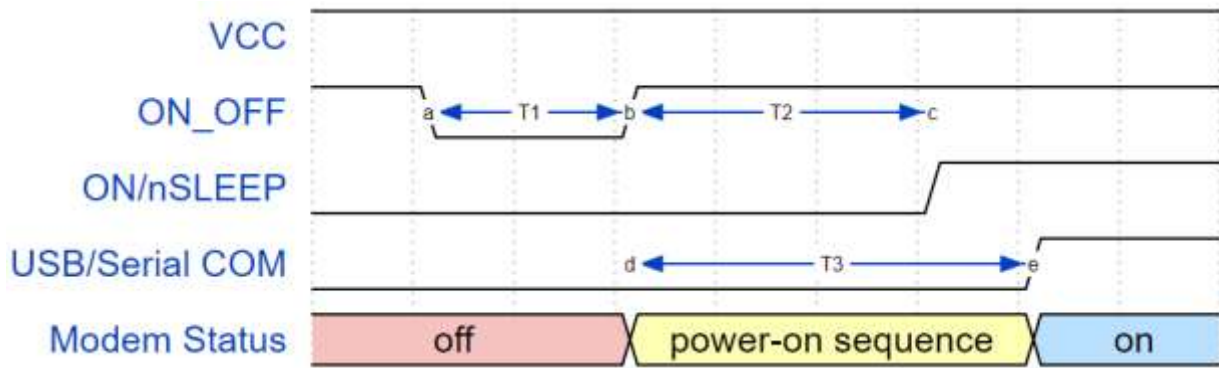

Modem	T1	T2	T3
NL-SW-LTE-TC1WWG	$1s \leq x \leq 2s$	~ 15s	~ 20s

Tying the ON\_OFF signal directly to ground to make the modem boot up when power is applied will cause the modem to automatically boot back up after a shutdown command is issued. This may prevent the modem from being able to shut down when the system is being powered off.

If the modem attempts to boot up while power is being removed it may suffer irreversible firmware corruption. Users are recommended to actively control this signal or use a one-shot circuit to apply the ON\_OFF signal when power is applied.

## 3.5.2 Shutdown

The modem may be properly powered off using one of the following methods:

- Hardware shutdown using the ON\_OFF signal.
- Shutdown using the "**AT#SHDN**" command.

Both of the shutdown options will force the modem to issue a detach request to the network, which informs the network that the device will be unreachable for an indefinite time. After issuing this request, the modem will power down.

For power sensitive applications it is also recommended to remove VCC and VREF from the Skywire after it has powered down. When the modem is powered down, the user must ensure that the modem is not being back-powered by any of its I/O lines.

Be sure to shut down the modem in a controlled manner, so as to allow the modem to gracefully detach from the network. Repeated failure to gracefully detach from the network during shutdown may result in the device being blacklisted from the network for a period of time, or indefinitely.

The duration of the shutdown process may vary from 15 seconds or longer. The host system should monitor the ON/nSLEEP pin to determine when the modem has powered down.

# PRELIMINARY VERSION

## 3.5.2.1 Hardware Shutdown

To shut down the modem using the hardware shutdown; tie the ON\_OFF signal low for 2.5 seconds. Use the same open-drain or open-collector circuitry for power-on. The user should monitor the ON/nSLEEP signal to ensure successful powering down of the modem. The power down sequence time can vary depending on the current network status of the modem.

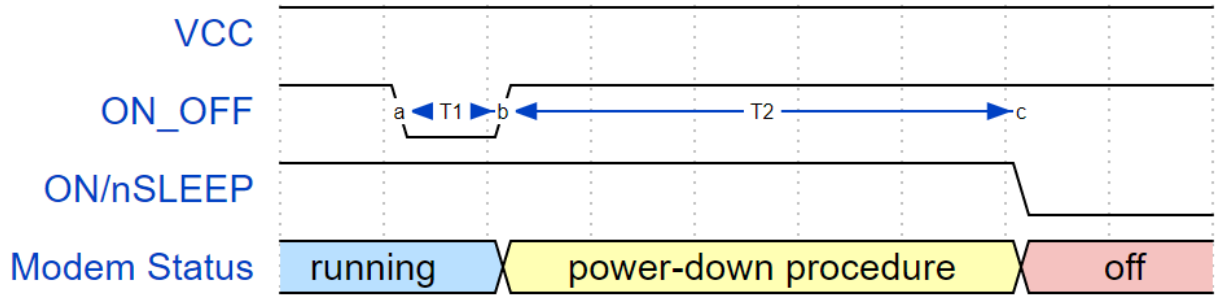

Modem	T1	T2
NL-SW-LTE-TC1WWG	$2.5s \leq x \leq 3s$	~ 15s

## 3.5.2.2 Software Shutdown

The modem can be shut down via AT command by issuing the "AT#SHDN" command to modem. When shutting down the modem via AT command, the ON\_OFF signal must not be grounded. The software power down sequence can take more than 10 seconds.

# PRELIMINARY VERSION

## 3.6 ON/nSLEEP

NL-SW-LTE-TC1WWG features a status LED that is connected to the ON/nSLEEP signal (pin J2-3). The ON/nSLEEP pin on the modem may be used for the following functions:

- Monitor power on status of the modem
- Network status monitoring

By default the pin is configured to monitor the network status of the modem.

### 3.6.1 Power Status Monitoring

To configure the ON/nSleep to function as a Power Status Monitor issue the following AT commands to the modem:

**AT#SLED=1**

**AT#SLEDSAV**

### 3.6.2 Network Status Monitoring

To configure the ON/nSleep to function as a Network Status Monitor, issue the commands below. **Note:** This is the firmware default state for this pin.

**AT#SLED=2**

**AT#SLEDSAV**

This AT command will enable the ON/nSLEEP signal to drive the status LED with the behavior listed in the table below:

Device Status	LED Behavior
Device Off	Permanently Off
Idle, Not Registered	Permanently On
Registered in Idle, with Power Saving	Fast Blinking (blinking period depends on network status)
Registered with Full Network Service	Slow Blinking (3 second period, T <sub>ON</sub> = 1s)

**Note:** The configuration of ON/nSLEEP as the status LED is not saved across resets. To save a modified configuration across reboots the "AT#SLEDSAV" command must be issued.

# PRELIMINARY VERSION

## 3.7 Firmware Updates Over the Air (FOTA)

LTE networks are constantly being updated, improved, and enhanced with new features. As a result, carriers are making frequent network changes. Most changes will not negatively affect devices connected to those networks, but occasionally an update will prevent an unprepared device from reconnecting to the network permanently.

To account for these future changes, FOTA (Firmware Over the Air) capability is being added to cellular modules by each manufacturer. NimbeLink supports this functionality in the entire Skywire family of embedded modems. Therefore, it is highly recommended that designers implement provisions to accommodate for FOTA processes.

Failure to accommodate FOTA processes may result in interruptions in cellular connectivity in the event of network changes. If a device can no longer access the network, FOTA cannot be used to remedy the problem. In this case, the only way to recover device functionality is to physically update the device firmware.

FOTA instructions are available by contacting NimbeLink's product support team at [product.support@nimbelink.com](mailto:product.support@nimbelink.com).

## 3.8 Soldered-Down Verizon SIM

The NL-SW-LTE-TC1WWG Skywire has the ability to select between a soldered-down Verizon SIM and a conventional 3FF SIM card inserted into the SIM slot, J3.

By default the modem prioritizes the 3FF SIM card and the soldered-down SIM interface is disabled until commanded otherwise with the AT commands listed in the following sections.

### 3.8.1 Enabling the Soldered-Down Verizon SIM

To enable the soldered-down SIM interface, issue the following commands:

```
AT#ENSIM2=1
```

```
AT#ENHRST=1,0
```

The modem will immediately reboot after entering the last command. When the modem becomes responsive again, the soldered-down SIM interface will now be enabled. The SIM enable command and SIM selection commands will not persist across carrier firmware switches with the AT#FWSWITCH command and must be reissued after the new firmware selection is loaded.

**Note 1:** Even after issuing the "AT#ENSIM2=1" command and rebooting, the 3FF SIM card interface will still be activated and selected.

**Note 2:** The "#ENSIM2: x" setting is saved in NVM, and will persist across device resets and power-ons. Additionally, the modem must reboot in order to save any changes made to this setting.

# PRELIMINARY VERSION

## 3.8.2 Swapping Between SIM Interfaces During Operation

After enabling the soldered-down SIM interface, it is possible to swap between the 3FF SIM card and the soldered-down SIM at will while the modem is powered on.

To instruct the modem to use the soldered-down SIM, issue the following AT commands:

```
AT+CFUN=4
AT#HSEN=1
AT#ENSIM2=1
AT#SIMSELECT=2
AT+CFUN=1
```

To instruct the modem to use the 3FF SIM Card in the SIM slot, issue the following AT commands:

```
AT+CFUN=4
AT#HSEN=1
AT#SIMSELECT=1
AT+CFUN=1
```

**Note 1:** Be sure to issue "AT+CFUN=4" each time before swapping the active SIM. This will allow the modem to gracefully detach from the network before swapping its SIM.

**Note 2:** The "#SIMSELECT:" setting is saved in NVM, and will persist after device resets and power-ons.

## 3.8.3 Disabling the Soldered-Down Verizon SIM Interface

If desired, the soldered-down SIM interface can be disabled using the following commands:

```
AT#ENSIM2=0
AT#ENHRST=1,0
```

The modem will immediately reboot after entering the last command. When the modem becomes responsive again, the soldered-down SIM interface will now be disabled.

**Note 1:** After issuing the "AT#ENSIM2=0" command, the modem will set its SIM selection state to: "#SIMSELECT: 1"

**Note 2:** The "#ENSIM2: x" setting is saved in NVM, and will persist across device resets and power-ons. Additionally, the modem must reboot in order to save any changes made to this setting.



# PRELIMINARY VERSION

## 3.9 Dual-Image Firmware Information

### 3.9.1 Overview

The NL-SW-LTE-TC1WWG has a dual-image firmware that allows the user to switch between Verizon and AT&T firmware images. These firmware images are swapped using the "AT#FWSWITCH" command.

**Note:** When swapping the active firmware image, the selection can be made to persist after reset by storing it in Non-Volatile Memory (NVM). See the commands below.

**Note:** Issuing the "AT#FWSWITCH" command performs a factory reset on the target firmware image. Any AT commands previously set, including but not limited to setting the APN and enabling and setting the second SIM interface, will need to be issued again once the firmware switch is complete.

### 3.9.2 AT#FWSWITCH Command Syntax

**AT#FWSWITCH=<net\_conf>[,<storage\_conf>[,<restore\_user\_conf>]]**

Argument	Default	Description
<net_conf>	2	Identifies the FW image to load: 0 = AT&T 1 = Verizon 2 = T-Mobile 3 = Bell 4 = Telus 40 = Global
<storage_conf>	1	Selects the storage configuration. Must be set to 1.
<restore_user_conf>	0	Determines if user settings will be restored after the firmware swap: 0 - Restore settings to default after FW swap 1 - Restore user settings after FW swap

**Note:** Use of the Global and AU firmware images may require additional certification for the customer's end-device, depending on unique carrier requirements.

# PRELIMINARY VERSION

## 3.9.3 Selecting the AT&T Image

To activate the AT&T configuration, issue one the following AT commands:

AT Command / Action	Description
AT#FWSWITCH=0,1,0 <b>OR</b> AT#FWSWITCH=0,1,1	Select the AT&T firmware configuration The third argument determines if user settings are restored: 0 - Restore default settings 1 - Restore user settings
<i>Wait for modem to reboot</i>	The Skywire will reboot automatically after sending the AT#FWSWITCH command

## 3.9.4 Selecting the Verizon Image

To activate the Verizon configuration, issue one the following AT commands:

AT Command / Action	Description
AT#FWSWITCH=1,1,0 <b>OR</b> AT#FWSWITCH=1,1,1	Select the Verizon firmware configuration The third argument determines if user settings are restored: 0 - Restore default settings 1 - Restore user settings
<i>Wait for modem to reboot</i>	The Skywire will reboot automatically after sending the AT#FWSWITCH command

## 3.10 GNSS

The NL-SW-LTE-TC1WWG Skywire features a built-in GNSS system that is capable of receiving the entire spectrum of GNSS systems available, including GPS, GLONASS, BeiDou, Galileo, and QZSS.

An active GNSS antenna must be used with the NL-SW-LTE-TC1WWG Skywire. The requirements for the GNSS antenna are available in [Section 3.10.1](#).

# PRELIMINARY VERSION

## 3.10.1 GNSS Antenna Requirements

It is required to use an active GPS antenna with the following specifications:

Item	Value
Antenna Type	GPS only
Antenna Gain	17 dB (typical)
Operating Voltage	3.3 VDC
Maximum Current	100 mA

Applications utilizing GLONASS require a GNSS pre-filter with the following specs:

Item	Value
Characteristic Impedance	50 $\Omega$
Insertion Loss (1575.42–1576.42 MHz)	1.4 dB (max)
Insertion Loss (1565.42–1585.42 MHz)	2.0 dB (max)
Insertion Loss (1597.5515–1605.886 MHz)	2.0 dB (max)

## 3.10.2 Active GNSS Antenna Control

A 3.3 VDC, 100 mA LDO regulator is available on the Skywire, and can be used to supply power to an external active GNSS antenna.

Control of the power supply for the active GNSS antenna is managed using GPIO5 on the modem. To conserve power, this regulator is turned off by default.

To turn on the regulator and power the external active GNSS antenna, issue one of the following commands to the modem.

```
AT#GPIO=5,1,1,0 // Turn on GPS, GPIO state will not persist after reset
```

```
AT#GPIO=5,1,1,1 // Turn on GPS, GPIO state will persist after reset
```

To disable the power to the external GNSS antenna, issue one of the following commands to the modem:

```
AT#GPIO=5,0,1,0 // Turn off GPS, GPIO state will not persist after reset
```

```
AT#GPIO=5,0,1,1 // Turn off GPS, GPIO state will persist after reset
```

# PRELIMINARY VERSION

## 3.11 Cellular Antenna Requirements

The NL-SW-LTE-TC1WWG Skywire modem supports a primary cellular antenna connection, and a diversity antenna connection. These connectors are U.FL connectors, and are labeled as X1 and X2, respectively.

The modem's primary antenna interface, X1, supports both TX and RX communication. The diversity antenna interface is an input for a second Rx antenna to improve radio sensitivity. According to carrier requirements, both the primary and the diversity antenna must be implemented.

**Note:** Many antennas require the use of a U.FL to SMA cable

### 3.11.1 Primary Antenna Requirements

Primary Antenna Requirements			
Frequency Range	Depending on the frequency bands provided by the network operator, the customer shall use the most suitable antenna for those bands		
Bandwidth	Band	TX	RX
	B1	1920 to 1980 MHz	2110 to 2170 MHz
	B2	1850 to 1910 MHz	1930 to 1990 MHz
	B3	1710 to 1785 MHz	1805 to 1880 MHz
	B4	1710 to 1755 MHz	2110 to 2155 MHz
	B5	824 to 849 MHz	869 to 894 MHz
	B7	2500 to 2570 MHz	2620 to 2690 MHz
	B8	880 to 915 MHz	925 to 960 MHz
	B9	1749.9 to 1784.9 MHz	1844.9 to 1879.9 MHz
	B12	699 to 716 MHz	729 to 746 MHz
B13	777 to 787 MHz	746 to 756 MHz	

# PRELIMINARY VERSION

	B14	788 to 798 MHz	758 to 768 MHz
	B19	830 to 845 MHz	875 to 890 MHz
	B20	832 to 862 MHz	791 to 821 MHz
	B25	1850 to 1915 MHz	1930 to 1995 MHz
	B26	814 to 849 MHz	859 to 894 MHz
	B28	703 to 748 MHz	758 to 788 MHz
<b>Primary Antenna Requirements</b>			
Impedance	50 ohm		
Input Power	≥ 24 dBm Average Power		
VSWR Max	≤ 10:1		
VSWR Recommended	≤ 2:1		

## 3.11.2 Diversity Antenna Requirements

The table below contains required specifications for the diversity antenna.

<b>Required Diversity Antenna Specifications</b>	
Impedance	50 Ω
VSWR Recommended <sup>1</sup>	≤ 2:1

1. Limit to obtain maximum sensitivity

## 3.11.3 Antenna Placement

The modem's cellular antenna placement will directly affect the modem's performance. It is vital that system designers carefully consider the placement of the

# PRELIMINARY VERSION

antenna and follow all of the guidelines and specifications set by the antenna manufacturer. The following guidelines are general recommendations for antenna installation:

- The antenna must have an impedance of 50 ohms.
- Keep the antenna cable as short as possible.
- The antenna must not be installed inside a metal enclosure, nor near metal objects unless specified by the antenna manufacturer.
- The antenna must be installed according to the manufacturer's instructions.
- Antenna gain must not exceed the values indicated in the regulatory requirements in [Section 5.7](#).
- Antenna integration should optimize antenna efficiency. Antennas are recommended to have >50% efficiency on all frequency bands.
- Antenna should not be mounted near noisy EM devices.

## 3.11.4 Recommended Antennas

While Skywire modems will work with antennas from other manufacturers, the following antennas have been designed specifically to work with Skywire.

Type	Manufacturer	Part Number
Internal Cellular Antenna	Airgain	F47AGBWA-G150U
External Cellular Antenna <sup>1</sup>	Airgain	ET56AGBJA

1. U.FL to SMA adapter required.

## 3.12 Skywire Reference Design

NimbeLink offers free reference schematic and layout files as examples of how to integrate Skywire modems into various systems. Schematics, design files, gerber files, and tutorials for a variety of different systems can be found on the Skywire Development Kits webpage: <https://nimbelink.com/development-kits/>

# PRELIMINARY VERSION

## 4. Mounting Guidelines

Skywire cellular modems support multiple connection methods. The two primary methods are board-to-board connectors and soldering directly to the baseboard.

### 4.1 Board-to-Board Connectors Approach

The Skywire interface calls for two 10-pin, 2mm pitch, female receptacles spaced 22 mm apart. There are many connector manufacturers that can be used. Below is one readily available product:

**Manufacturer:** Sullins Connector Solutions

**Part Number:** NPPN101BFCN-RC

Typical part drawing and footprint information for the NPPN101BFCN-RC connector:

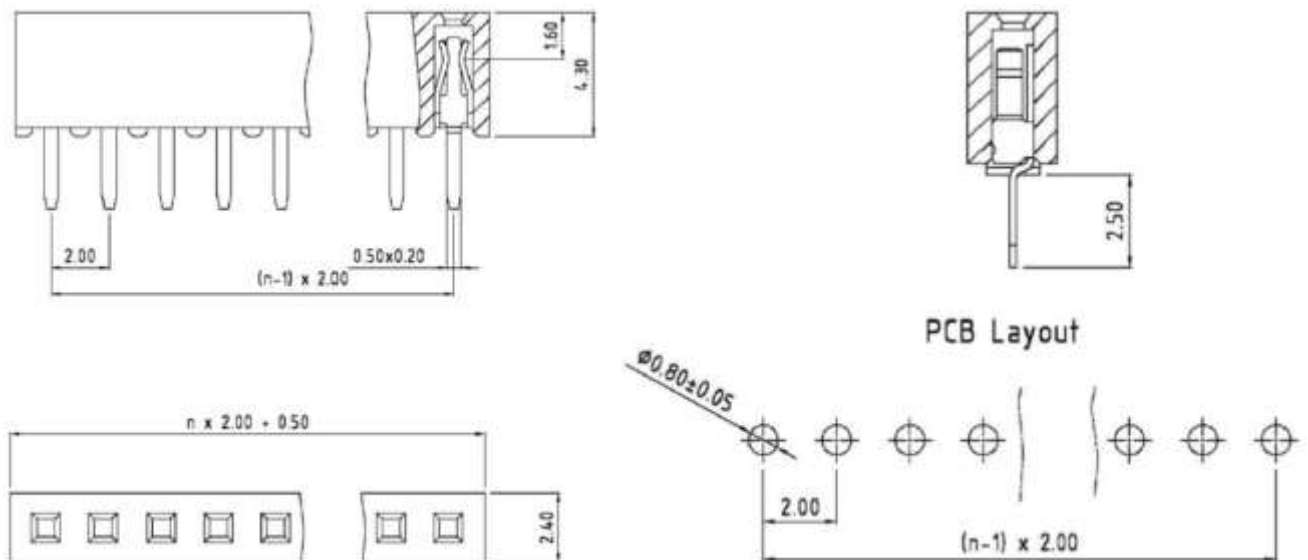

#### 4.1.1 Mechanical Retention

Certain applications where the modem is mounted on the host board using the connector approach detailed in Section 4.1 may need to mechanically secure the Skywire modem and its SIM card in order to prevent the modem from vibrating out of the mating connectors.

# PRELIMINARY VERSION

Skywire modems do not have any dedicated attachment points for securing to the host board, however it can easily be secured by one of the following methods:

- Zip ties
- Foam tape mounted on the Skywire to press against the enclosure
- Mechanical retention of the modem and SIM by the enclosure (example below)
- [https://nimbelink.com/Documentation/Skywire/1001460\\_Mechanical\\_Retention\\_Enclosure.pdf](https://nimbelink.com/Documentation/Skywire/1001460_Mechanical_Retention_Enclosure.pdf)
  - Solder the Skywire to the host board (as described in Section 4.2)

## 4.2 Solder to Board Connection

Skywires can be soldered directly to a PCB. The PCB should be designed with two rows of ten 0.8mm plated through holes spaced 2mm apart. The two rows should be 22mm apart. See the figure below for the recommended footprint.

All measurements are in millimeters. U.FL locations are marked with circles, X1 and X2 are on the top of the board. J3 is the Micro SIM card slot on the bottom side of the board.

**Coming Soon**



# PRELIMINARY VERSION

## 5. Regulatory Information

### 5.1 FCC & IC Compliance

If the modem's antenna is located farther than 20cm from the human body and there are no adjacent transmitters, the FCC/IC approvals of the on-board Telit LE910C1-WWX cellular module can be reused by the end product.

Should the modem's antenna be mounted closer than 20cm from the human body or if there are adjacent transmitters, additional FCC/IC testing may be required for the end product.

NL-SW-LTE-TC1WWG modems make use of the on-board Telit LE910C1-WWX module's FCC & IC identification numbers.

Orderable Device	FCC ID	IC ID (certification number)
NL-SW-LTE-TC1WWG	RI7LE910CXWWX	5131A-LE910CXWWX

The FCC certificate is available at the following link by searching for the FCCID listed above: <https://www.fcc.gov/oet/ea/fccid>

The IC ID certificate is available at the following link by searching for the IC ID listed above: <https://sms-sgs.ic.gc.ca/equipmentSearch/searchRadioEquipments?execution=e1s1&lang=en>

### 5.2 Regulatory Certifications

- **FCC ID:** RI7LE910CXWWX
- **IC:** 5131A-LE910CXWWX
- **PTCRB:** Coming Soon

### 5.3 Carrier Specific Certifications

- **AT&T:** Coming Soon
- **Verizon:** Coming Soon

### 5.4 Export Control Classification Number (ECCN)

ECCNs are five character alphanumeric designations used on the Commerce Control List (CCL) to identify dual-use items for export control purposes. An ECCN categorizes items based on the nature of the product, i.e. type of commodity, software, or technology and its respective technical parameters.

**ECCN for All Skywire Modems:** 5A992.c

# PRELIMINARY VERSION

## 5.5 Harmonized Tariff Schedule Code

**HTS Code:** 8517.62.0010

## 5.6 Interference Statement

This device complies with Part 15 of the FCC Rules and Industry Canada license-exempt RSS standards. Operation is subject to the following two conditions: (1) This device may not cause harmful interference, and (2) this device must accept any interference received, including interference that may cause undesired operation.

## 5.7 Wireless Notice

In order to maintain FCC/IC radiation exposure limits set forth for an uncontrolled environment alongside carrier specific certifications the antennas cannot exceed the maximum gain levels listed here:

Band	Frequency	Max Antenna Gain
B2	1900 MHz	9.01 dBi
B4	1700 MHz	6.00 dBi
B5	850 MHz	10.41 dBi
B7	2600 MHz	9.01 dBi
B8	900 MHz	10.79 dBi
B12	700 MHz	9.70 dBi
B13	700 MHz	10.17 dBi
B14	700 MHz	10.23 dBi
B25	1900 MHz	9.01 dBi
B26	850 MHz	10.36 dBi

## 5.8 Modification Statement

Nimbelink has not approved any changes or modifications to this device by the user. Any changes or modifications could void the user's authorization to operate the equipment.

## 5.9 End Product Labeling Requirements

End products utilizing NL-SW-LTE-TC1WWG modems should be labeled with the following information:

# PRELIMINARY VERSION

Device Uses Approved Radio: NL-SW-LTE-TC1WWG

Contains FCC ID: RI7LE910CXWWX

Contains IC: 5131A-LE910CXWWX

This device complies with Part 15 of the FCC Rules and Industry Canada license-exempt RSS standards. Operation is subject to the following two conditions: (1) This device may not cause harmful interference, and (2) this device must accept any interference received, including interference that may cause undesired operation.

# PRELIMINARY VERSION

## 6. Document Version Information

Revision	Description	Date
0	- Preliminary Release	3/31/2021