



**DLP-TILT**

## USB-BASED TILT SENSOR / ACCELEROMETER / VIBRATION ANALYSIS / AC SIGNAL ANALYSIS MODULE

### Features:

- Microcontroller Preprogrammed with Data-Acquisition Functions
- 2-Axis, 2g Accelerometer
- Single-Byte Access to All Firmware Features
- Continuously Streaming Analog Sample Rates from 100 to 6K Samples Per Second
- 4<sup>th</sup>-Generation USB Interface Silicon from FTDI (FT232R with internal ceramic resonator, internal setup EEPROM, and clock output for microcontroller)
- Virtual COM Port Drivers for Easy Programming Interface

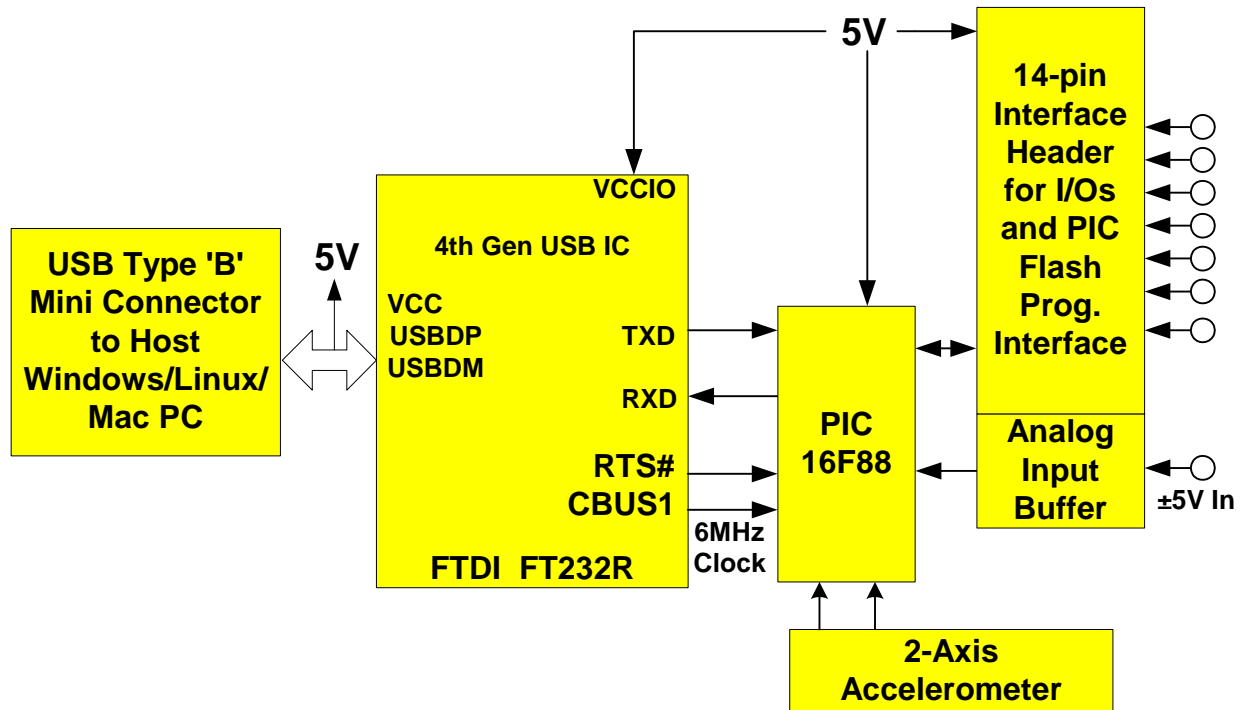

### APPLICATIONS:

- 2-Axis Tilt Sensor
- Vibration Analysis (2-Axis, up to 3000Hz)
- Two-Button Mouse (Pointing Device Alternative)
- FFT-Based AC Analysis to 3KHz with Provided Software
- +/-5V Analog In (Single Channel)
- Data Acquisition: 0-5V Analog In, Digital I/O
- Robotic/Motion Sensing and Control

## 1.0 INTRODUCTION

The DLP-TILT USB-to-accelerometer module has four primary applications: (1) vibration analysis, (2) tilt sensing, (3) AC signal analysis, and (4) two-button mouse pointing device alternative.

### 1.1 VIBRATION ANALYSIS

This module is designed to provide vibration analysis using an on-board, 2-axis, 2g accelerometer that is designed for analysis of frequencies up to 3000 Hz. Two of the analog channels in the microcontroller are dedicated to the on-board accelerometer.

### 1.2 TILT SENSING

When used as a tilt sensor, the accelerometer can measure tilt up to approximately  $\pm 60$  degrees from center in both the X- and Y-axes. The position is reported as an 8-bit or 10-bit integer with the center position reporting the half-scale value of 128 (8-bit) from the A/D converter in the microcontroller. The A/D converter can also be run in 10-bit resolution mode with a resulting mid-scale value of 512.

### 1.3 AC SIGNAL ANALYSIS

Voltage data from the seven analog channels can be sampled at rates ranging from 100 samples per second to 6000 samples per second, thereby enabling AC analysis of audio frequencies up to 3KHz. One module input channel is dedicated to an analog input buffer that allows for voltages in the range of  $\pm 5$  volts to be acquired. The remaining channels allow voltages in the range of 0-5 volts to be acquired.

The microcontroller and preprogrammed firmware used in this design utilize single-byte commands to control all aspects of operation. Once the channel and sample rates have been selected, continuous streaming of A/D data can be enabled and disabled by sending a single-byte command. Data received by the host PC can be analyzed for frequency content using an FFT-based Windows application available as a free download from the DLP Design website upon purchase of the module.

### 1.4 POINTING DEVICE

The DLP-TILT's preprogrammed firmware includes the feature set of a standard two-button mouse with the motion of the cursor controlled by the tilt of the DLP-TILT's printed circuit board and accelerometer.

When the board is level, the cursor remains motionless. As the board is tilted from center, the cursor begins to move in the direction of the tilt. The further the board is tilted, the faster the cursor moves across the screen. Two of the digital I/O lines serve as inputs for the buttons. Shorting these lines to ground will cause the firmware to issue the "Button Down" signal to the host PC, thereby mimicking the operation of standard mouse buttons.

Shorting a pin to ground in the interface header before powering up the DLP-TILT activates the two-button mouse functionality. *Refer to Section 2.0 for the I/O lines associated with the Pointing Device mode of operation.*

## 2.0 ELECTRICAL INTERFACE DESCRIPTION

Refer to the electrical schematic at the end of this document for additional details.

Pin	Description	Comments
1	MCLR	Pulling this pin to ground will reset the microcontroller. See <i>Note1</i> .
2	Vin	Analog input for voltages in the range of $\pm 5V$ .
3	SWVCC	5 Volt output; switched on once host enumeration is complete. See <i>Note1</i> .
4	A2	Analog in (0-5V) or digital I/O.
5	Ground	<i>Note1</i> .
6	A3	Analog in (0-5V) or digital I/O.
7	B7	Analog in (0-5V) or digital I/O. See <i>Note1</i> , <i>Note2</i> .
8	B0	Digital I/O; Left mouse button, active low. See <i>Note2</i> .
9	B6	Analog in (0-5V) or digital I/O. See <i>Note1</i> , <i>Note2</i> .
10	B1	Digital I/O. Right mouse button, active low. See <i>Note2</i> .
11	B3	Digital I/O. If held low at power up, Pointing Device functionality is activated. See <i>Note2</i> .
12	Ground	
13	Ground	
14	Ground	

Note1: These pins are used for reprogramming the Flash program memory area (a user-supplied device programmer is required).

Note2: Weak pull-ups in the microcontroller are enabled for Port B by default.

## 2.1 SOFTWARE INTERFACE DESCRIPTION

Royalty-free Virtual COM Port drivers are available for immediate download from [www.dlpdesign.com](http://www.dlpdesign.com). The VCP drivers are available for the following systems:

- Windows 98 / 98 SE / 2000 / ME / XP
- Windows CE\*
- MAC OS-8 and OS-9\*\*
- MAC OS-X\*\*
- Linux 2.40 and greater

*\*In planning or under development.*

*\*\*Pointing Device features are not supported on MAC systems.*

The DLP-TILT supports two standard baud rates: 38,400 (power-up default) and 128,000 baud. Communication with the DLP-TILT is accomplished by simply opening the COM Port at 38,400 baud and sending single-byte commands. The commands are outlined in Section 3.0.

## 2.2 QUICK START GUIDE FOR WINDOWS

- A. Download the modified Virtual COM Port (VCP) drivers from [www.dlpdesign.com](http://www.dlpdesign.com). Unzip these files into a new folder. The VCP drivers that are part of the Windows XP operating system will not work as the PID code has been changed to FBFA.

- B. Connect the DLP-TILT module to the host PC, then load the USB drivers obtained in Step A.
- C. Open Device Manager and look in "Ports (COM & LPT)" to determine the COM port number that Windows has assigned to the DLP-TILT module.
- D. Run Windows HyperTerminal by clicking the Start menu, selecting Programs, and navigating through Accessories to the HyperTerminal folder. Select the following parameters:

**Bits Per Second:** 38,400  
**Data Bits:** 8  
**Parity:** None  
**Stop Bits:** 1  
**Flow Control:** Hardware

- E. Press the letter 'P' on the keyboard. The letter 'Q' should appear in the HyperTerminal window. (Please note that all commands are case sensitive.)

At this point the DLP-TILT module is set up and ready for use with either one of the Windows applications provided by DLP Design or your own custom software.

### 3.0 COMMAND SET

To operate the DLP-TILT, the host application simply has to open the COM port assigned to the module, set the baud rate to 38,400, and send single-command bytes. A complete list of command bytes is presented here:

*Please note that the ASCII characters are case sensitive.*

Command	Hex	ASCII Character (Case Sensitive)	Comments
<b>PING</b>	0x50	P	DLP-TILT will return "Q" (0x51) if module is present and port is open.
<b>SET BAUD RATE:</b>			
38,400 Baud	0x69	i	Default
128,000 Baud	0x39	9	
<b>A/D OUTPUT RESOLUTION:</b>			
8-Bit Data Returned	0x51	Q	Default
10-Bit Data Returned	0x52	R	
<b>A/D RETURN DATA TYPE:</b>			
Binary/Counts	0x53	S	Default
ASCII Text	0x54	T	
<b>A/D SAMPLE RATE (TIMER INTERVAL):</b>			
100 Hz	0x41	A	
200 Hz	0x42	B	
300 Hz	0x43	C	
500 Hz	0x44	D	

1.0 KHz	0x45	E	
1.5 KHz	0x46	F	
1.8 KHz	0x47	G	Default
2.0 KHz	0x48	H	
2.5 KHz	0x49	I	
3.0 KHz	0x4A	J	
4.0 KHz	0x4B	K	
5.0 KHz	0x4C	L	
6.0 KHz	0x4D	M	
<b>A/D CHANNEL SELECT:</b>			
Ch0 (AN0 / A0)	0x30	0	
Ch1 (AN1 / A1)	0x31	1	
Ch2 (AN2 / A2)	0x32	2	
Ch3 (AN3 / A3)	0x33	3	
Ch4 (AN4 / A4)	0x34	4	
Ch5 (AN5 / B6)	0x35	5	
Ch6 (AN6 / B7)	0x36	6	
<b>A/D CLOCK SELECTION:</b>			
A/D Off	0x61	a	
Internal	0x62	b	Default
Divide by 64	0x63	c	
Divide by 32	0x64	d	
Divide by 16	0x65	e	
Divide by 8	0x66	f	
Divide by 4	0x67	g	
Divide by 2	0x68	h	
<b>A/D CHANNEL ENABLE: (Channels 0, 1 and 4 are Analog In Only)</b>			
Ch2 Enable	0x6A	j	
Ch3 Enable	0x6B	k	
Ch5 Enable	0x6C	l	
Ch6 Enable	0x6D	m	
<b>A/D CHANNEL DISABLE: (enable digital I/O) and Return High/Low State</b>			
Ch2 Disable	0x6F	o	Return A2 High/Low State
Ch3 Disable	0x70	p	Return A3 High/Low State
Ch5 Disable	0x71	q	Return B6 High/Low State
Ch6 Disable	0x72	r	Return B7 High/Low State

<b>MAKE DIGITAL OUTPUT AND CLEAR TO LOW :</b>			
Port A2	0x74	t	
Port A3	0x75	u	
Port B0	0x76	v	
Port B1	0x77	w	
Port B3	0x78	x	
Port B6	0x2D	-	
Port B7	0x3D	=	
<b>MAKE DIGITAL OUTPUT AND SET HIGH:</b>			
Port A2	0x55	U	
Port A3	0x56	V	
Port B0	0x57	W	
Port B1	0x58	X	
Port B3	0x59	Y	
Port B6	0x5B	[	
Port B7	0x5D	]	
<b>RETURN SINGLE A/D CONVERSION TO HOST USING CURRENT SETTINGS:</b>			
	0x37	7	
<b>BEGIN STREAMING A/D CONVERSION DATA TO HOST USING CURRENT SETTINGS:</b>			
	0x38	8	Halt on Any Character Received
<b>RETURN 8-BIT A/D CONVERSION DATA TO HOST FOR BOTH CHANNELS OF THE ACCELEROMETER:</b>			
	0x7A	z	2 Bytes Returned
<b>RETURN 8-BIT A/D CONVERSION DATA FOR ALL 7 CHANNELS</b>			
	0x73	s	7 bytes returned

## 4.0 DEMONSTRATION SOFTWARE

Three demonstration programs are available for the DLP-TILT module: AcqFFT.exe, DLPTilt.exe, and DLPVib.exe. All three programs are available for download from the DLP Design website upon purchase of the DLP-TILT module.

## 4.1 ACQFFT.EXE

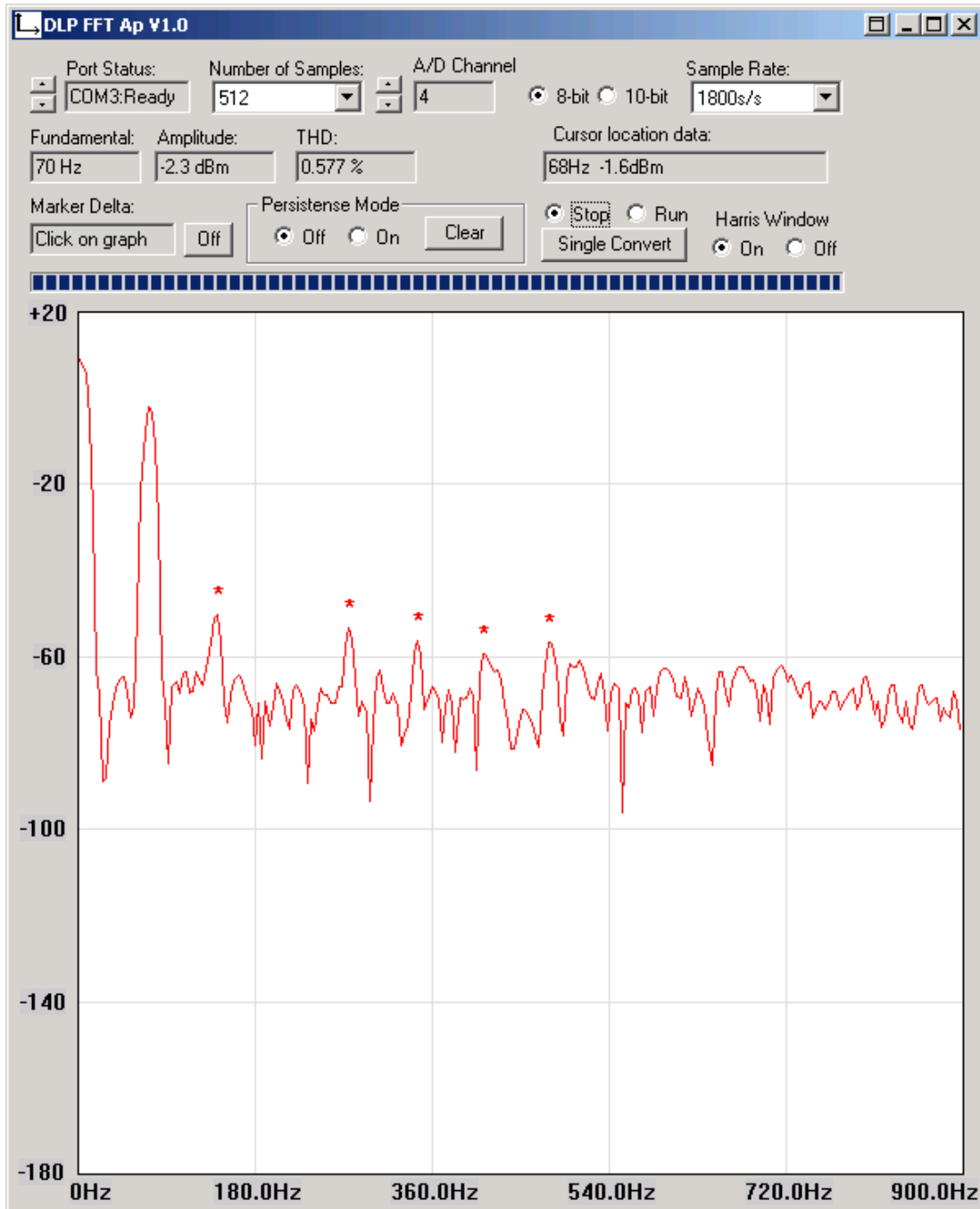

This program is designed to acquire AC signal data from any of the seven analog inputs on the DLP-TILT, then calculate and display the FFT of the signal and provide some basic analysis. Numerous program settings are possible including setting the COM port, A/D channel on the microcontroller, sample rate, number of samples, and a continuous run mode.

## 4.2 DLPTILT.EXE

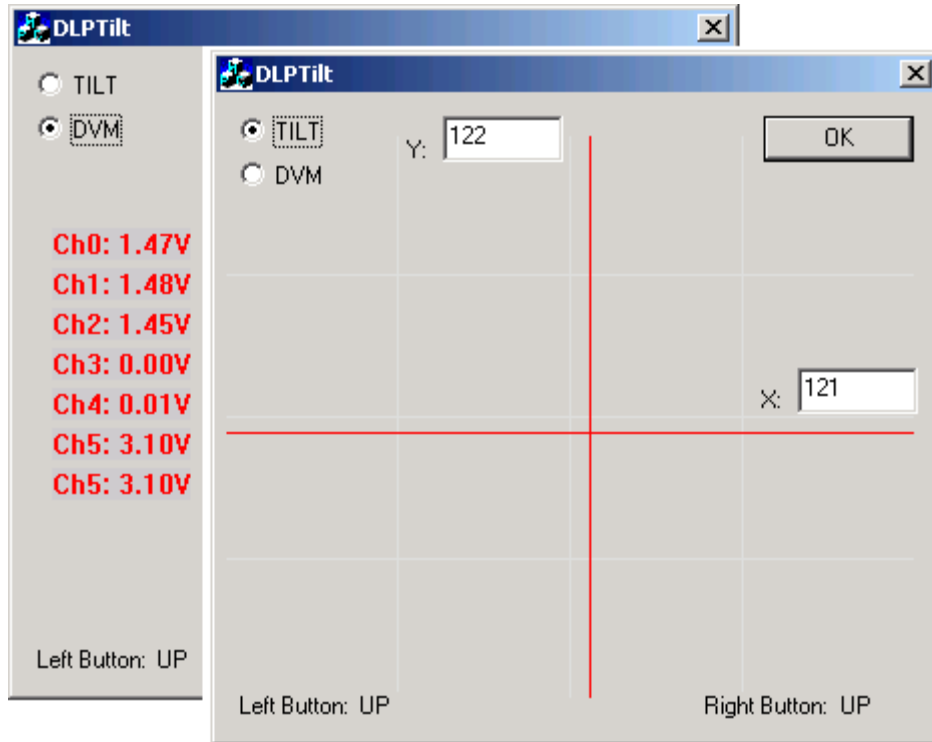

This program is designed to both demonstrate the tilt feature of the accelerometer and present the acquired voltages from each of the seven analog inputs.

## 4.3 DLPVIB.EXE

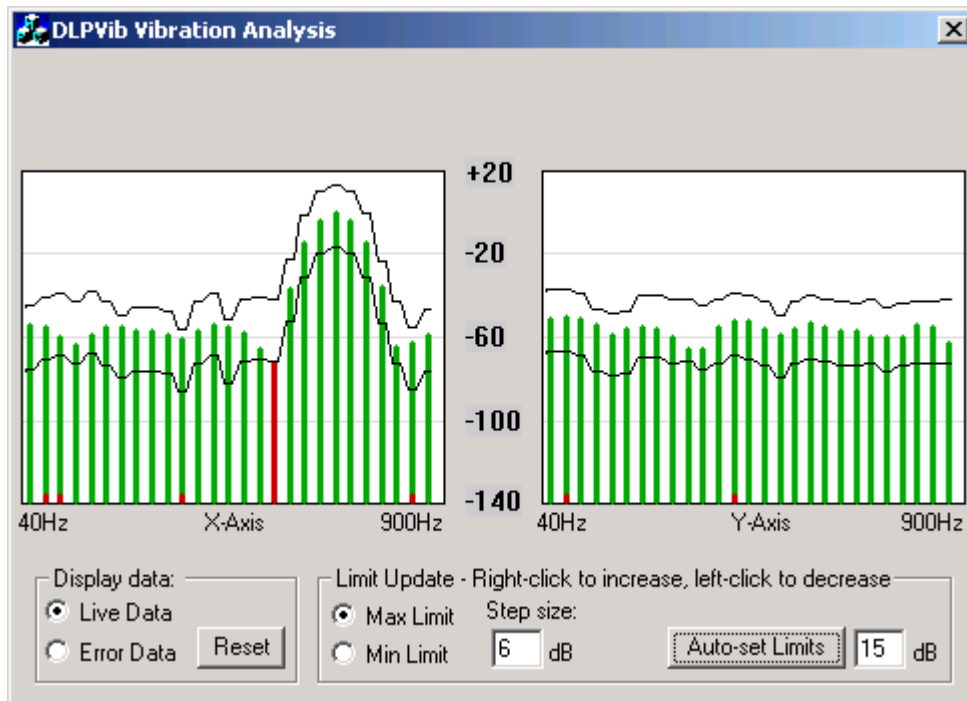



This program is designed to monitor both channels of the accelerometer and graphically display frequency and amplitude data proportional to the vibration. Limits can be set such that an error indication is made when any frequency component rises or falls out of the limits.

## 5.0 MECHANICAL DIMENSIONS IN INCHES (MM) (PRELIMINARY)

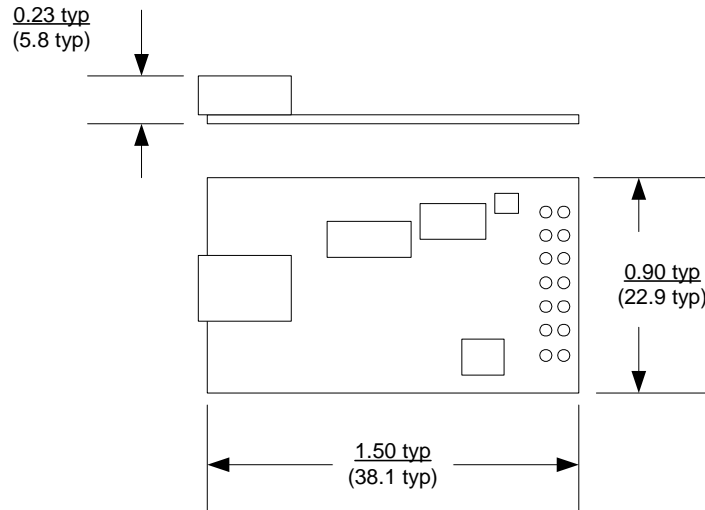

## 6.0 DISCLAIMER

© DLP Design, Inc., 2006

Neither the whole nor any part of the information contained herein nor the product described in this manual may be adapted or reproduced in any material or electronic form without the prior written consent of the copyright holder.

This product and its documentation are supplied on an as-is basis, and no warranty as to their suitability for any particular purpose is either made or implied. DLP Design, Inc. will not accept any claim for damages whatsoever arising as a result of the use or failure of this product. Your statutory rights are not affected. This product or any variant of it is not intended for use in any medical appliance, device, or system in which the failure of the product might reasonably be expected to result in personal injury.

This document provides preliminary information that may be subject to change without notice.

## 7.0 CONTACT INFORMATION

DLP Design, Inc.  
1605 Roma Lane  
Allen, TX 75013

Phone: 469-964-8027  
Fax: 415-901-4859

Email Sales: [sales@dlpdesign.com](mailto:sales@dlpdesign.com)  
Email Support: [support@dlpdesign.com](mailto:support@dlpdesign.com)  
Website URL: <http://www.dlpdesign.com>